Time-Encoded Imaging of Energetic Radiation

**J. Brennan, E. Brubaker, M. Gerling, P. Marleau,
A. Nowack, P. Schuster**

**Sandia National Laboratories
Livermore, CA**

SPIE Optics & Photonics 2013

Outline

- **What is time-encoded imaging?**
- **Standoff SNM detection: the PRISM concept**
- **Large scintillator cells with good PSD**
- **Candidate cell comparison & selection**
- **Cell characterization**
 - **Position dependence, energy, PSD**
- **Conclude**

What is Time-Encoded Imaging?

- Time-encoded imaging is in many ways analogous to coded aperture imaging:
 - The *spatial* modulation of a particle flux induced by a fixed mask on a *position-sensitive image plane* is replaced by the *time* modulation of a particle flux induced by a moving mask on one or a few *time-sensitive detectors*.

Coded Aperture Imaging

- Aperture is used to modulate the flux emitted by an unknown source distribution
 - Modulated flux intensity is measured at the detector plane by a position sensitive detector

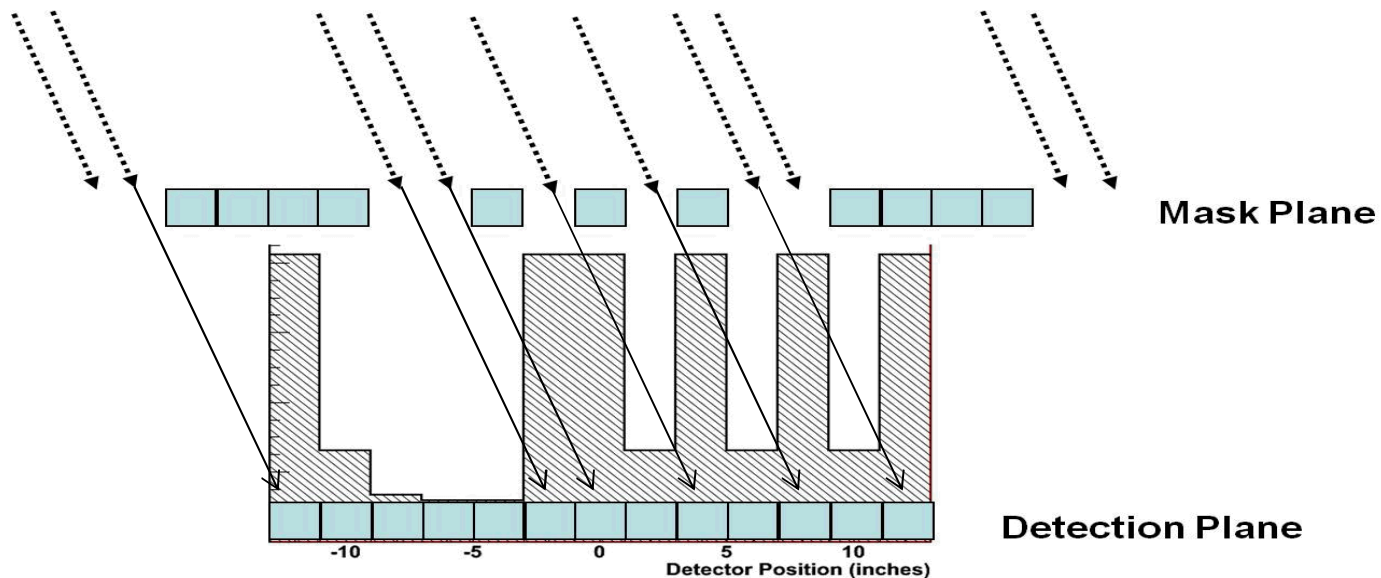

Time-Encoded Imaging

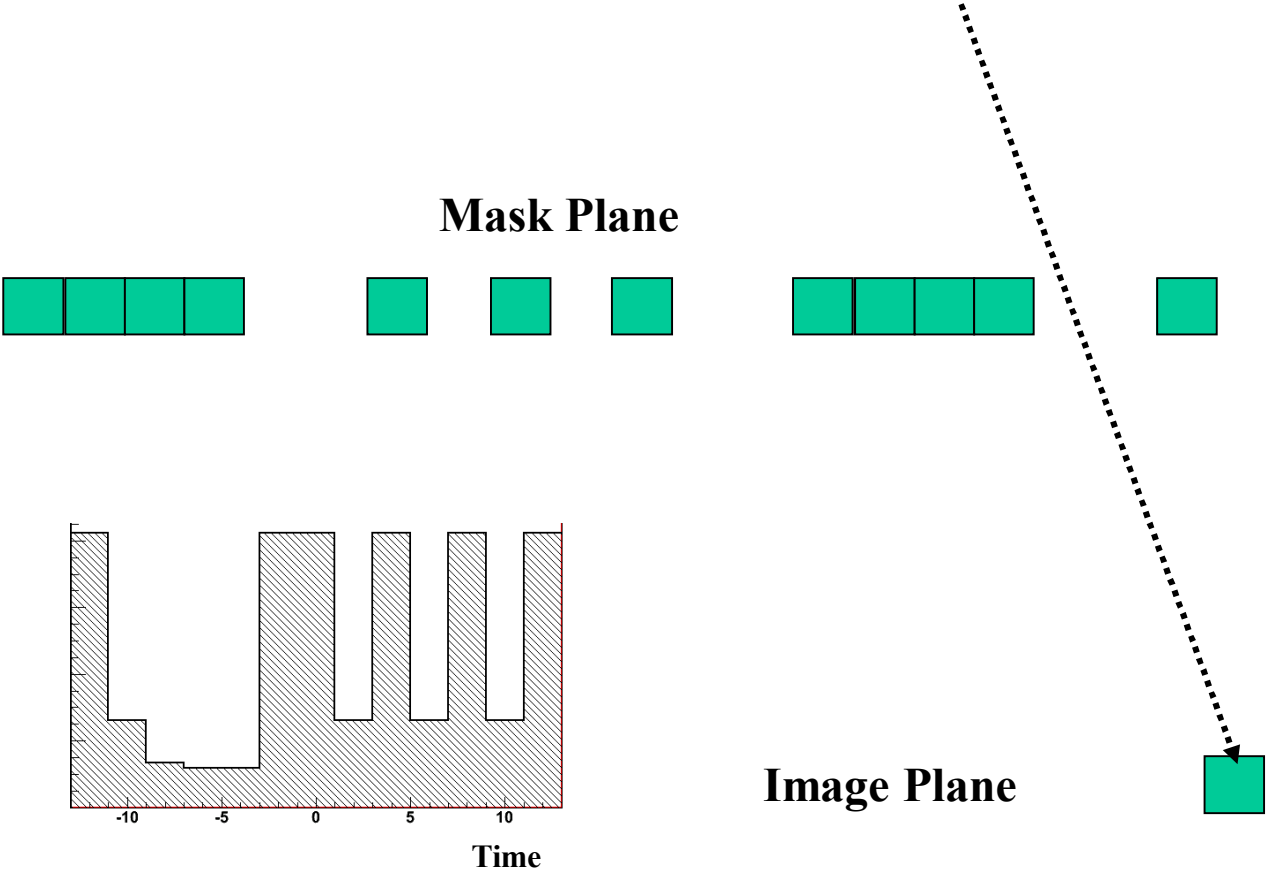

Time-Encoded Imaging vs Coded Aperture Imaging

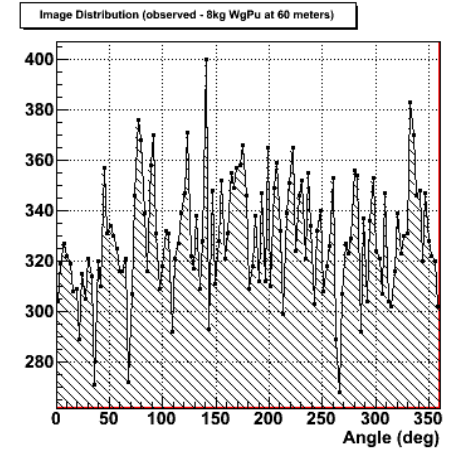
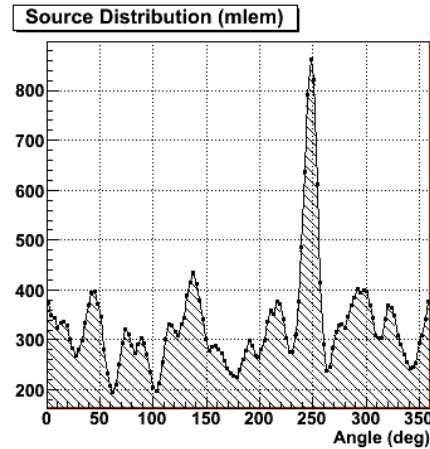
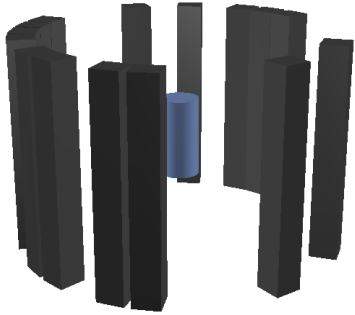

- TEI is related to coded aperture imaging, but switch spatial modulation for time modulation.
 - Spatial resolution in detectors is expensive. Time resolution in detectors is ~free!
 - Accurately resolving spatial patterns requires precise inter-calibration of detector channels or regions. In TEI, a single detector can be used; or if multiple, they are independent.
- **Simple and robust, low-channel-count** detectors.
- **Scalable** to large effective area.

Standoff detection

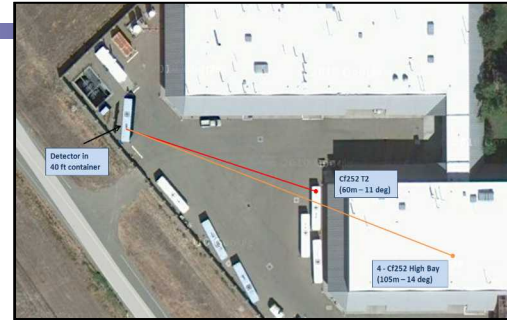
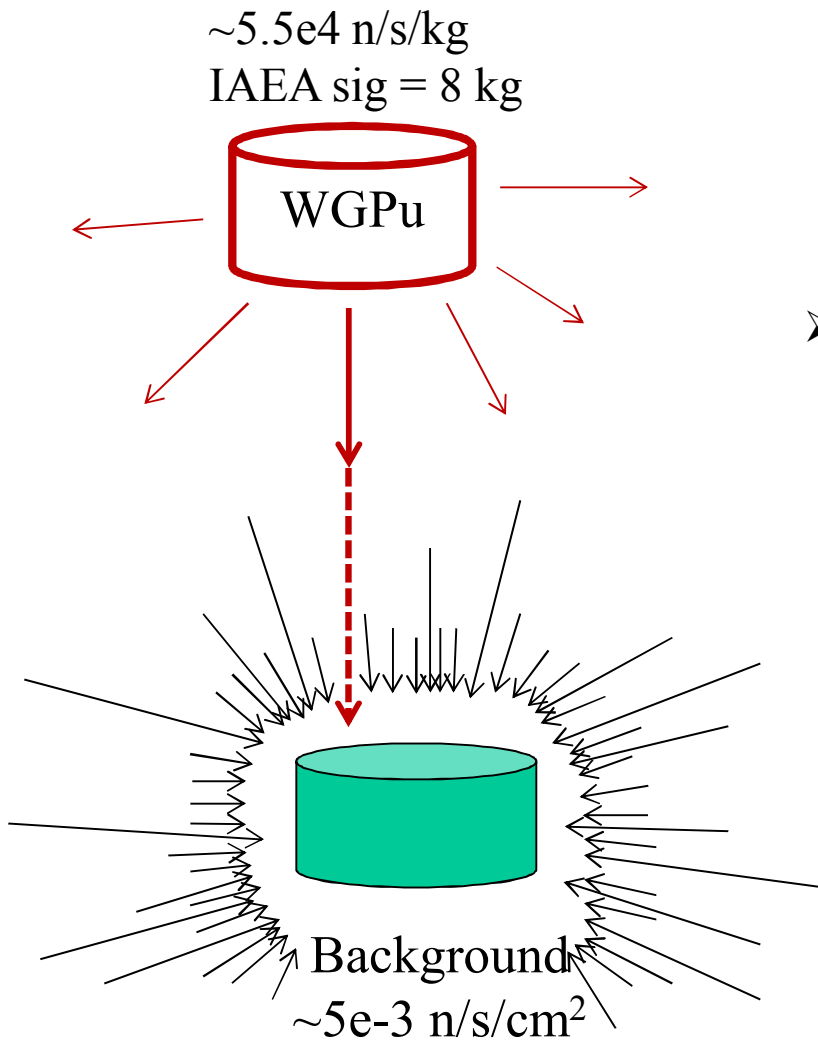

➤ Example: Large stand-off application (100 meters)

- 8 kg WGPu = ~4.4e5 n/s →
4.4e5 * exp(-R/100)/4πR² ≈ 1.3 n/s/m²
- Background = ~50 n/s/m² (at sea level)
- 100% efficient, 1 m² detector →
5σ detection in ~13 minutes
- 10% efficient, 1 m² detector →
5σ detection in ~2 hours
- 10% efficient, 1 m² detector, 3% bg rate systematic → 5σ detection in **never**

TEI for source detection

- Take advantage of scaling to large effective area.
- Directional information distinguishes a localized source from more diffuse background.
 - High resolution not necessary.
 - Goal is detection, not imaging per se.
- Typical scenarios need sensitivity to sources on the “horizon”, in azimuthal direction.
 - One dimensional imaging suffices.
- Focus on fast neutron signature—specific to SNM, has most benefit from directional information.

PRISM: Rotation Self-Modulation

- Detectors act as masks for each other
- More compact and more easily scalable at the cost of less optimal modulation pattern

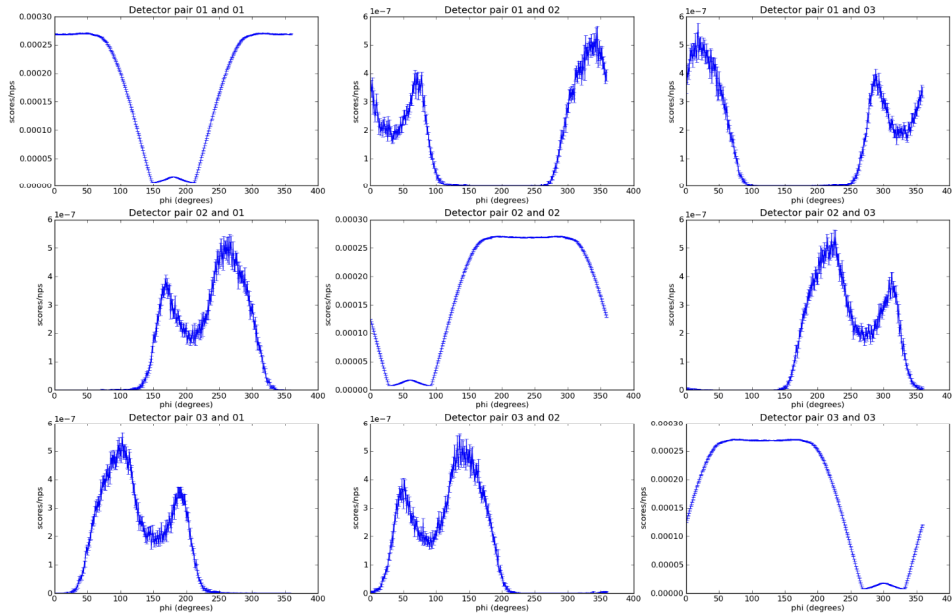

Detector response vs rotation angle for a fixed source location



- First test was done with PRISM in outside trailer
- Stand-off Cf-252 ($4e5$ n/s) source placed at several positions
 - Three locations from 10m distance
 - 100 second dwell time

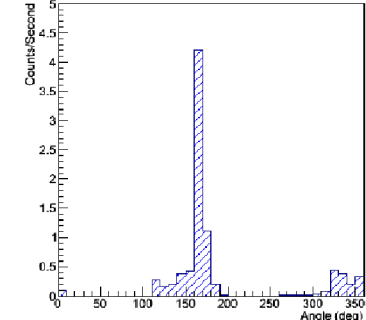
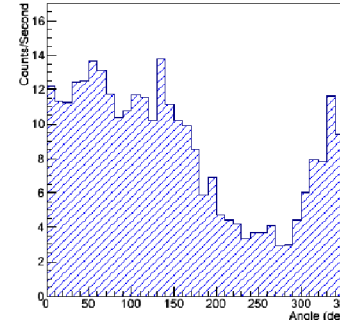
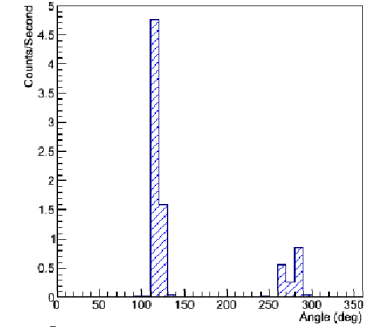
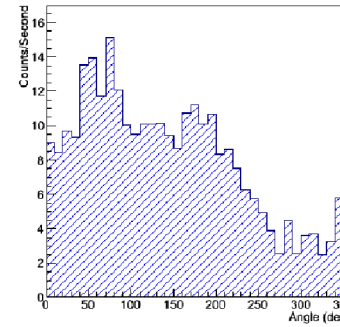
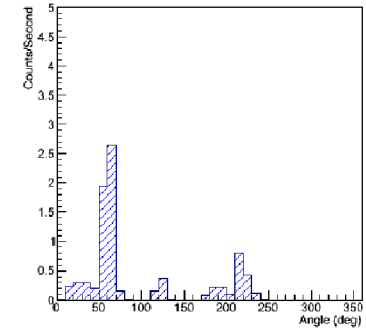
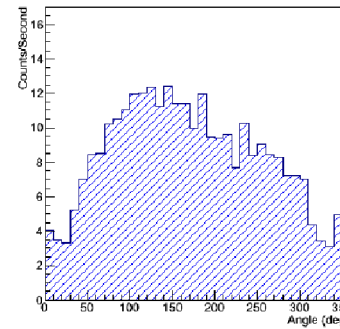

- Source standoff increased to 60m
- 1.3 hours of dwell time
- PMT gain affected by geomagnetic fields.
 - Installation of magnetic shielding for subsequent tests

Source Distribution (mlem)

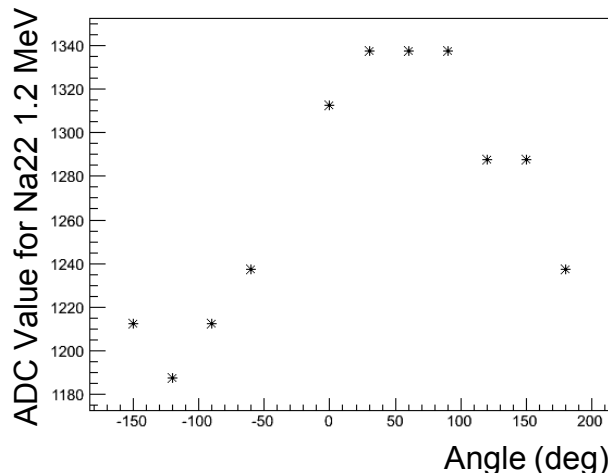
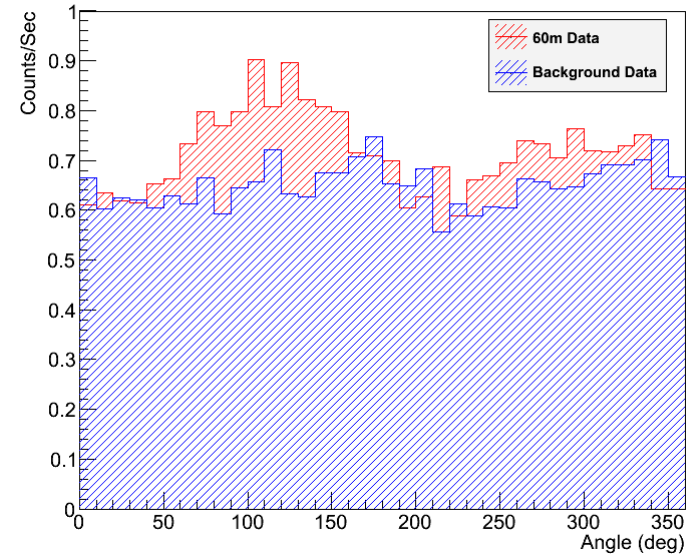

- Moving detector cells changes modulation pattern
 - How does this affect performance?
- Many shapes were tested using MCNP/Polimi generated data
 - WGPU point-source placed 60m, uniform sea-level background



Square

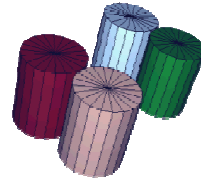
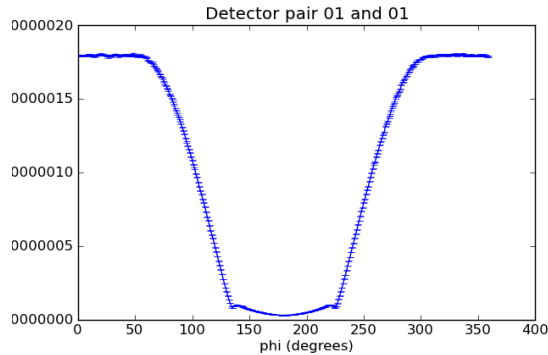

Rectangle

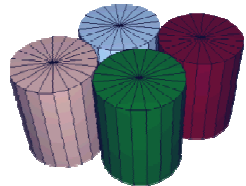
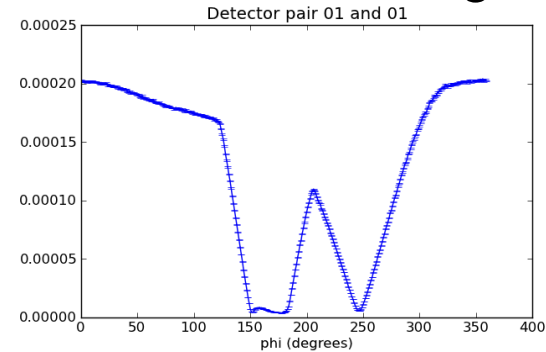

Diamond

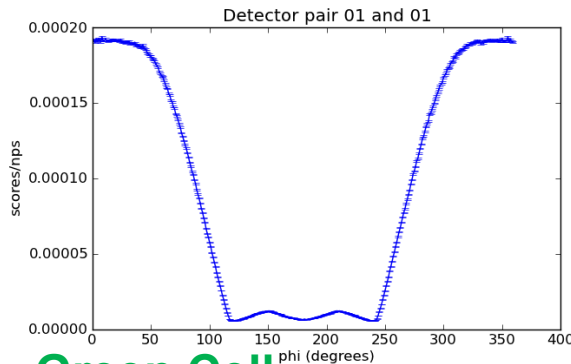

Green Cell

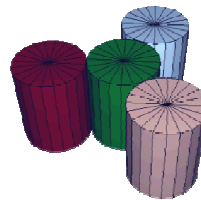

Clover

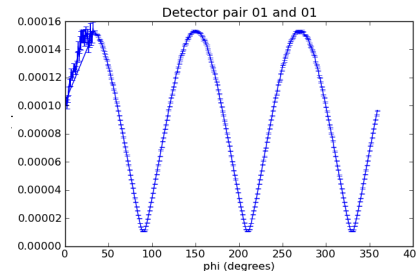

Inner Cell

Outer Cell

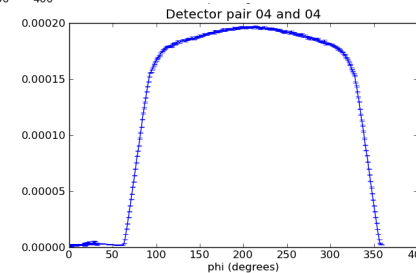

- Feed generated data back into hypothesis test routine
- It is possible for a 4-cell configuration to perform worse than a 3-cell configuration!

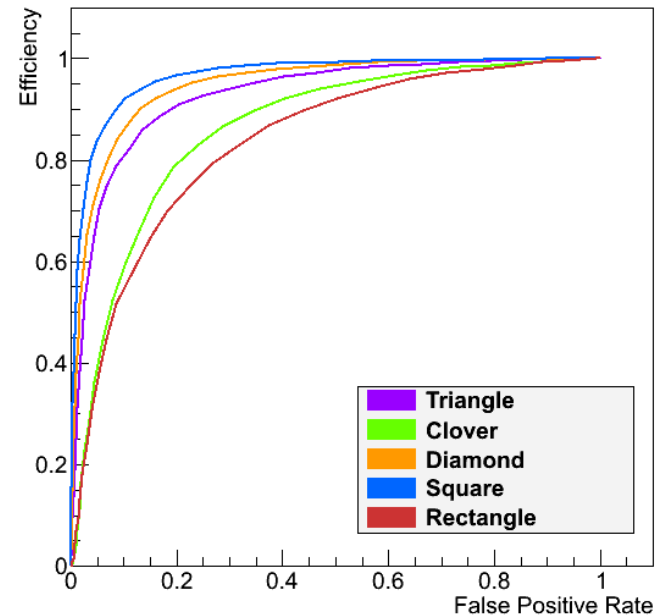

Scalability: at what cost?

- SNM detection relies on detector volume and efficiency.
- Good Neutron / Gamma discrimination and lower energy thresholds contribute to higher detector efficiencies

PRISM 27 L

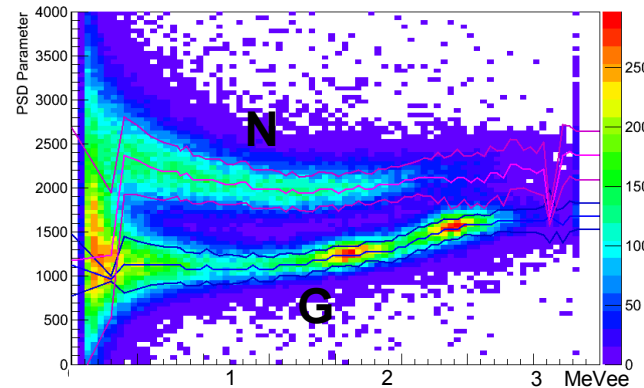
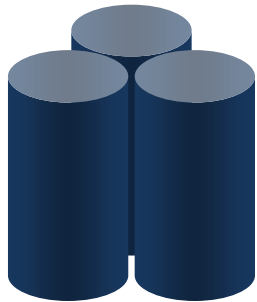

Larger cells suffer from longer PMT response, decreased transit time resolution, and worse light collection.

LIGHTHOUSE 1.6 L

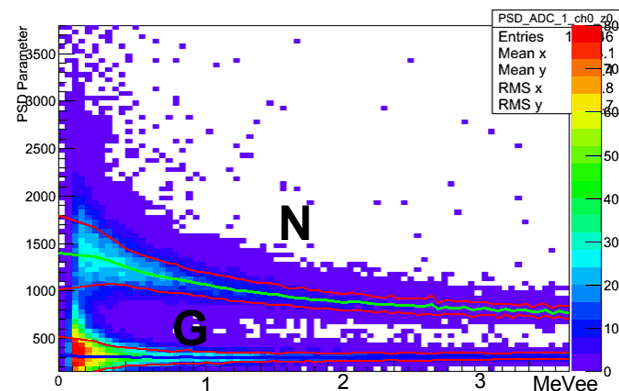
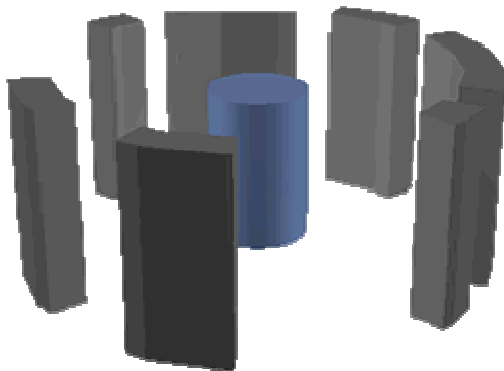

PRISM has a ~4x higher threshold than LIGHTHOUSE, removing a larger portion of the fission spectrum.

- Of the three Photonis PMTs used for PRISM, only one had acceptable PSD performance. Still significantly worse than LIGHTHOUSE cell.
- Light collection and PMT response are the main factors for obtaining adequate PSD in large volumes.
- Large PMTs frequently used for neutrino physics in low photon counting experiments.
 - Poor response, non-linearity, decreased dynamic range
- Seek to improve or at least match performance of best 9” PMT, while maintaining low channel count (one PMT per cell).

- Many leftover XP1802 from previous neutrino experiments, various states of condition. Test cell to compare performance

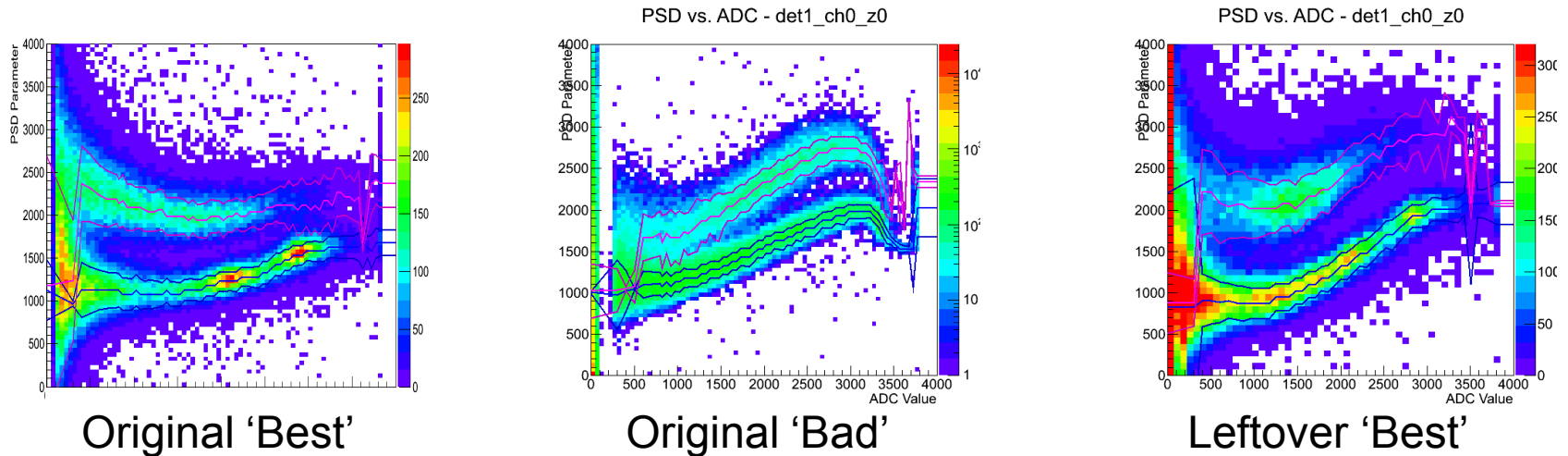

- Leftover PMTs exhibited distortion, suppression at low and high energies. ~10 PMTs examined with varying degrees of performance.

- Used larger PMT to increase light collection → Better PSD?
- Borrowed 10" Hamamatsu R1950 PMT from LLNL

PSD4 vs Ampl2

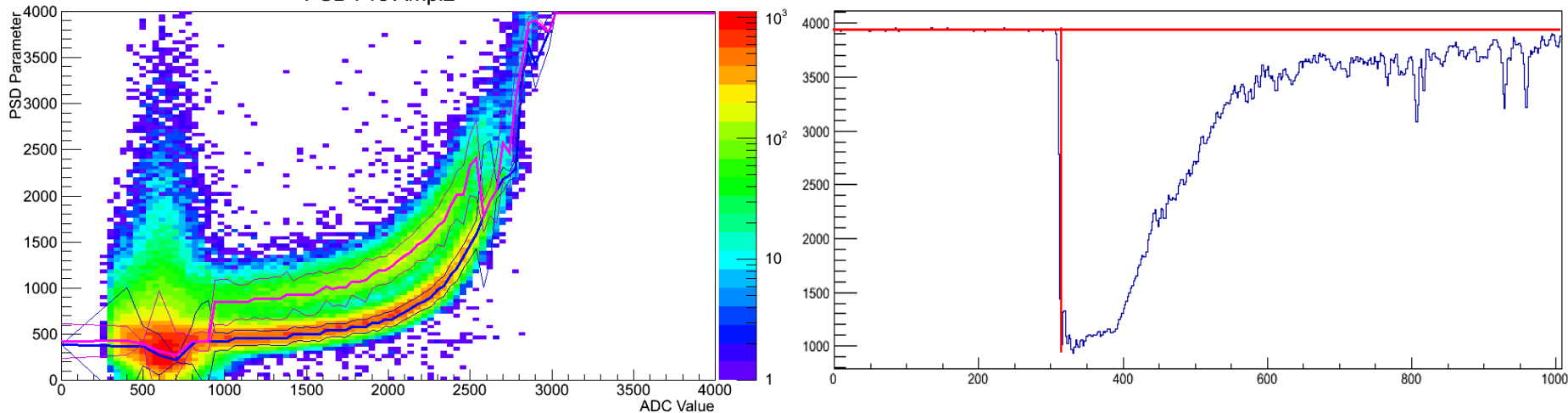

- Severely distorted response and pulse saturation
- <1 MeV dynamic range
- Second deposit of photoelectrons 60ns later and more up to 200ns, “afterpulsing”

- 5" Hamamatsu H6527 → Good response, well tested for PSD
 - Lower light collection

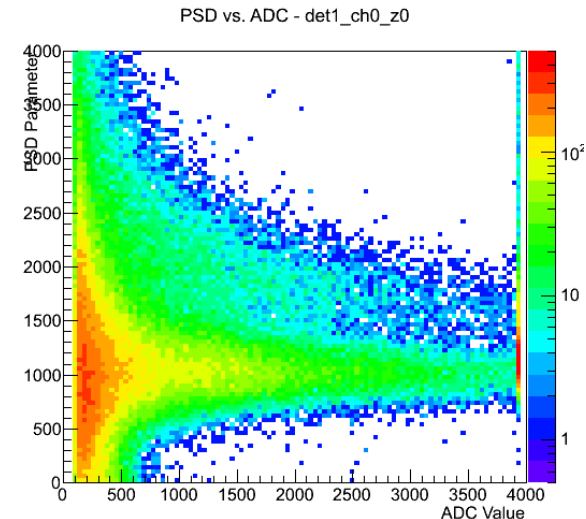
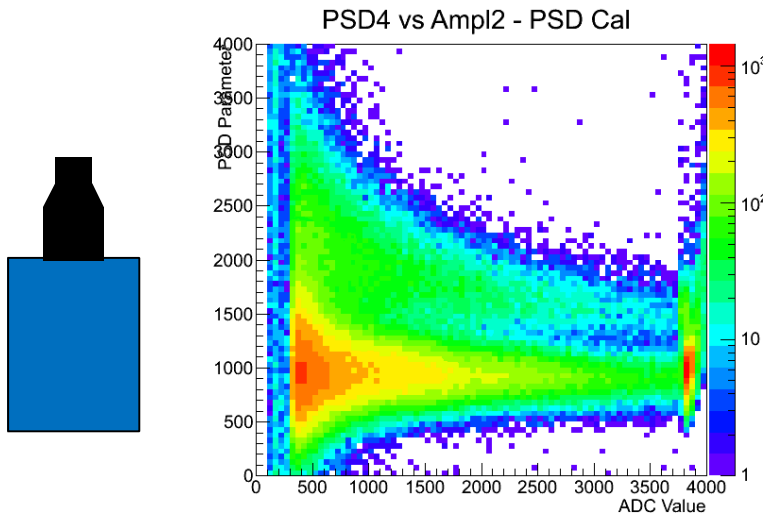

- Linear response, large dynamic range
- PSD performance is less than desired, tried lightpipe to create more uniform response over interaction position

3-PMT configuration

- Combine the signal from three PMTs viewing the same cell to improve light collection.
- The good qualities of the H6527 PMT plus better photostatistics results in good PSD performance.

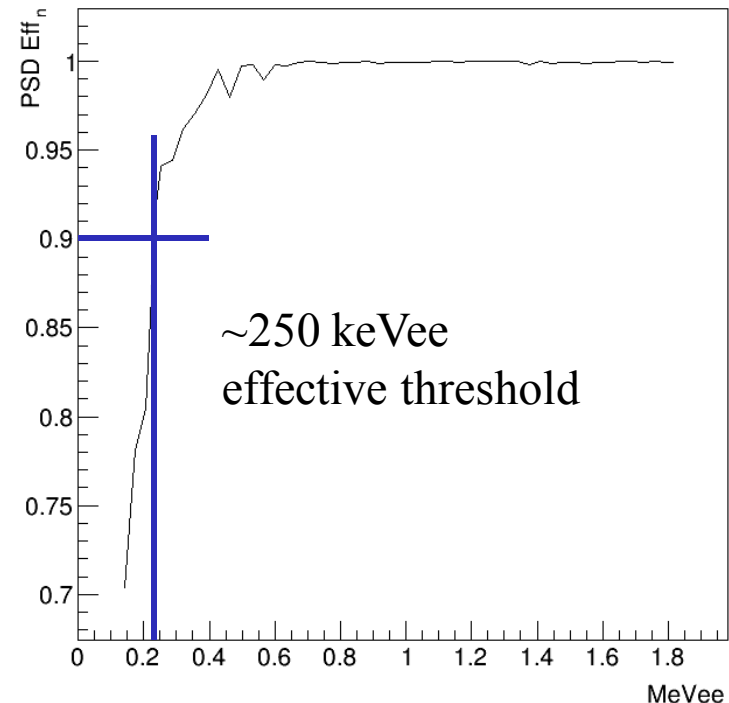
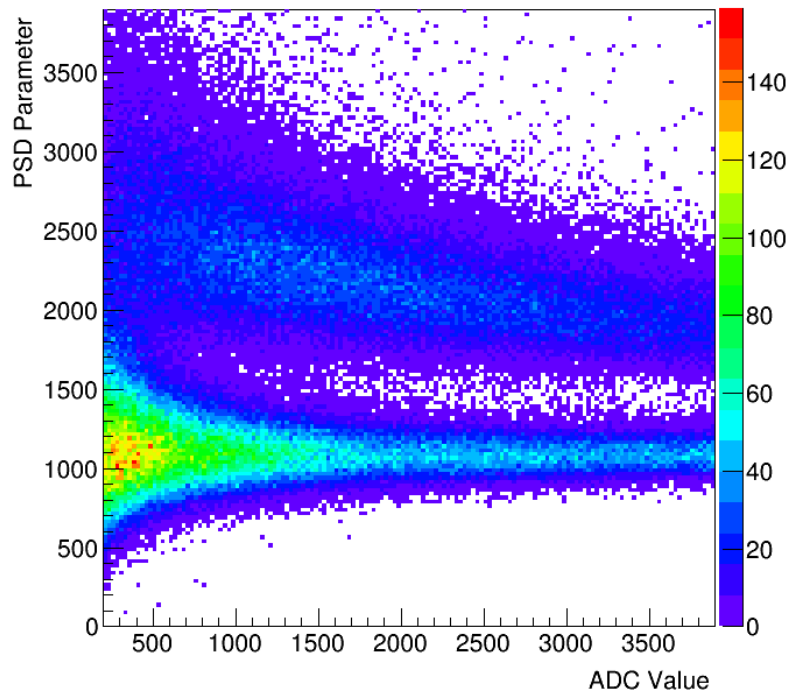

- Na-22 source data allows a fitting procedure to determine gain, as well as resolution parameters for this cell.

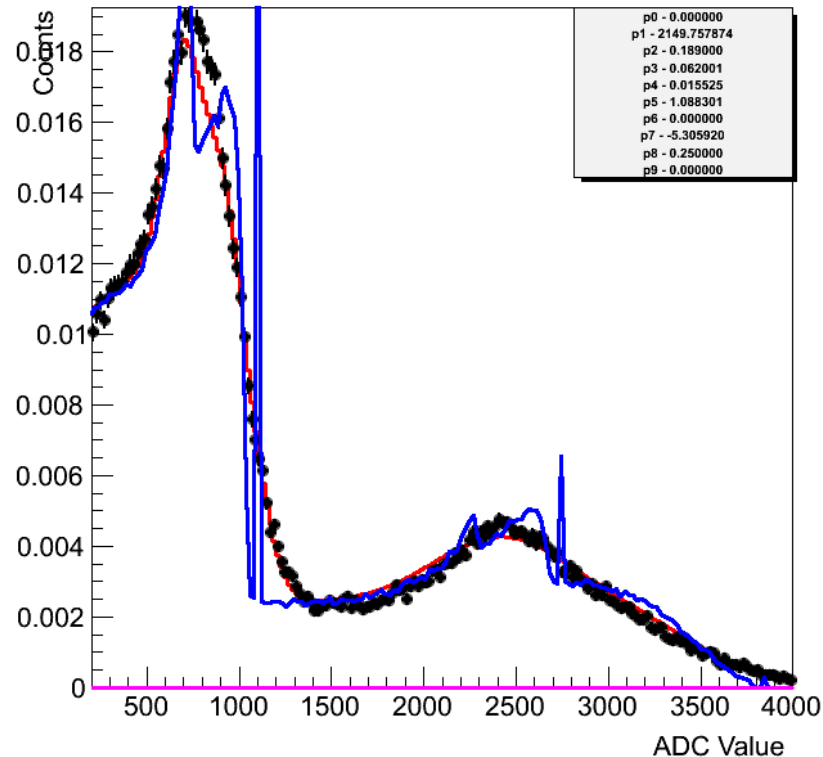

- Since the cell is large and the multiple PMTs create an azimuthal asymmetry, is there dependence on the source/interaction phi? **No.**

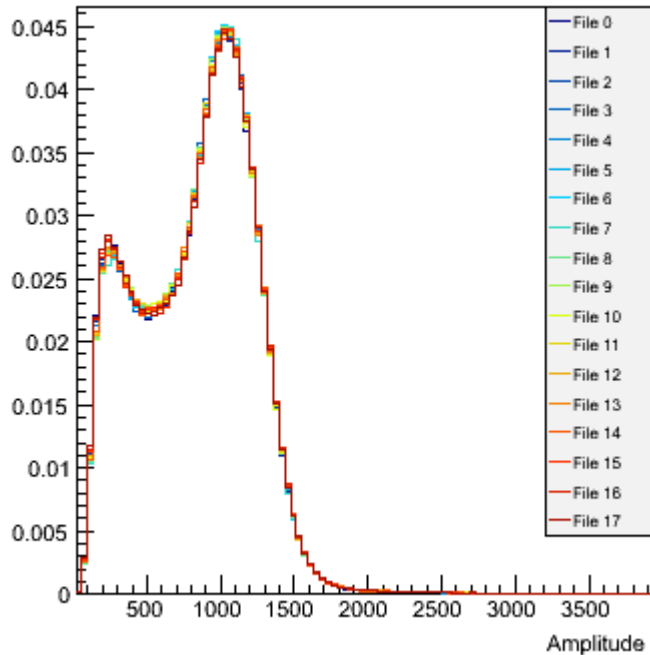

- Since the cell is large and the PMTs are clustered on one end of the cylinder, is there dependence on the source/interaction z? **Yes.**

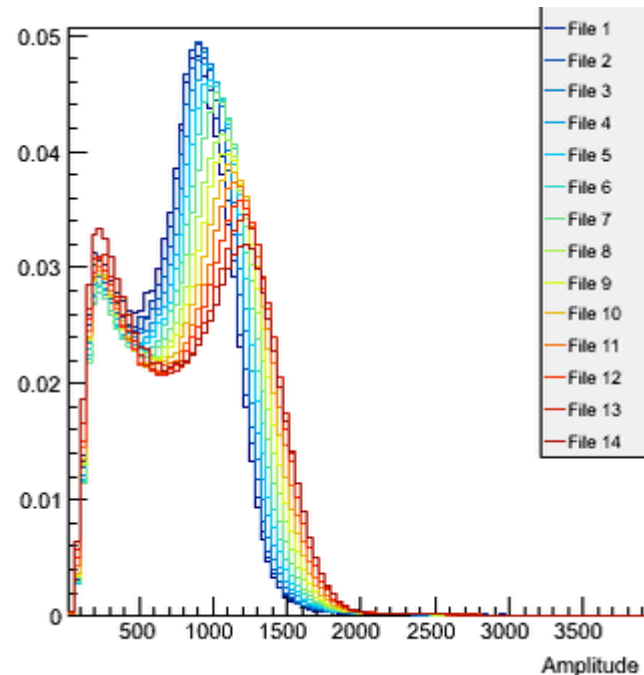

- Note this is relevant for cell performance, but does not bias the PRISM system.

- Detector systems based on time-encoded imaging can be simple & robust, low-cost, but highly scalable.
- Scaling to large neutron-sensitive detector elements requires special attention to pulse shape discrimination performance.
- We achieved a 23 L liquid scintillator cell configuration (11”D x 15”) with sufficient PSD performance by combining the signal from three 5” PMTs.
 - 90% neutron identification efficiency with 99.99% gamma rejection above ~250 keVee.
- This detector performance enables a sensitive SNM standoff detector system based on the time-encoded imaging concept.



Additional Slides

Why focus on “imaging” neutrons?

- Consider the weak source detection problem
 - Low S:B
- Little signal-to-background discrimination from neutron spectral information.
- Directional information helps
 - Distinguish signal from background— isolate a point source.
 - Produce image of multiple or extended radiation sources.

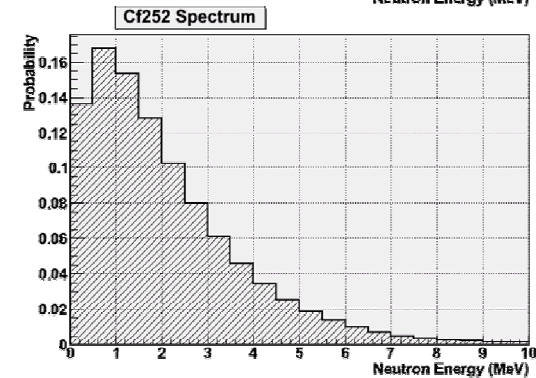
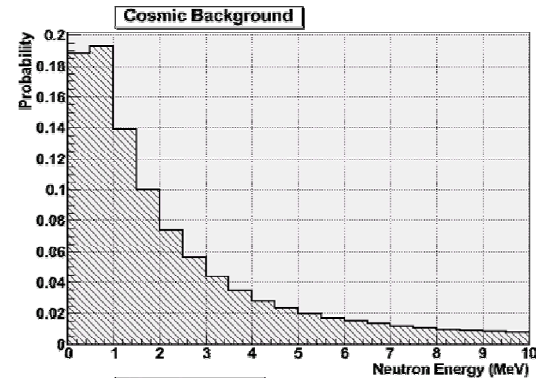

Neutron directional detectors

Common features

- **N-P elastic scattering**
- **Liquid scintillator based.**
 - **Gamma discrimination**
- **Sensitivity to direction**
 - **Event by event (kinematics)**
 - **Statistical (many events form a pattern)**
- **Shielding is hydrogenous material.**

System attributes

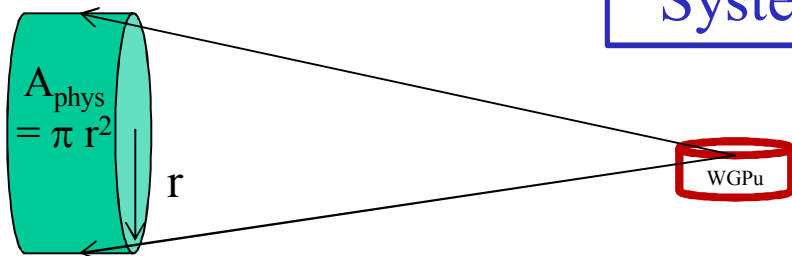

- **Effective area:** area over which the detector would be 100% efficient.
- Physical cross-sectional area times the detection efficiency.

$$A_{\text{eff}} = A_{\text{phys}} * \epsilon$$

- **System angular resolution:** resolution of the reconstructed image in the far field.
- **Event angular resolution:** resolution on the direction of a single event.

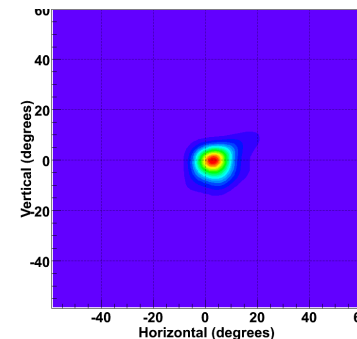

Likelihood ratio method

- If signal and background behavior are known, the likelihood ratio is a sensitive test statistic to distinguish between them.
- By definition, encodes probability of statistical fluctuations.
- Systematic uncertainties can be accounted for as nuisance parameters.
 - Integrate over them: Bayesian.
 - Fit for most likely (given constraints): Frequentist.

$$LLR = \ln \frac{L(\text{data} | s + b)}{L(\text{data} | b)}$$

Either approach introduces significant complexity and computation, but improves robustness → reduces false alarm rate.

Point source SNM search

- Our assumptions:
 - The background is known.
 - Can be relaxed later by introducing background systematics.
 - The relevant signal is a *single* point source within the field of view.
 - Restricting the hypothesis space to a single point source “sharpens” the hypothesis test and reduces false alarms.
 - Should be valid in the vast majority of cases; algorithm performance may still be acceptable in outlier scenarios.

Test statistic

- Loop over possible point source locations (in field of view).
- For each source position, find LLR = $\Delta(\ln L)$ between b-only and s+b hypotheses.
 - Signal strength is unknown, so maximize LLR over signal fraction f :
 - $LLR = \max_f (\ln L(\text{data}|n_s=fN) - \ln L(\text{data}|n_s=0))$.
- The largest LLR obtained from any potential source position is the test statistic.
 - Effectively profile likelihood over source position, strength.

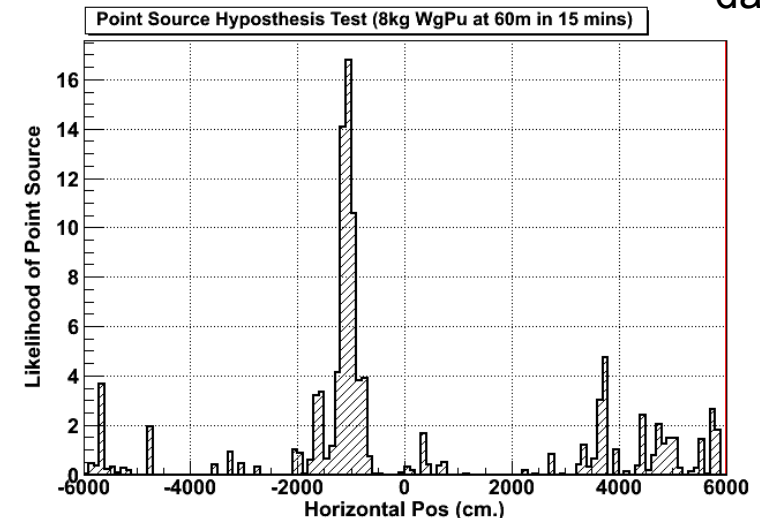
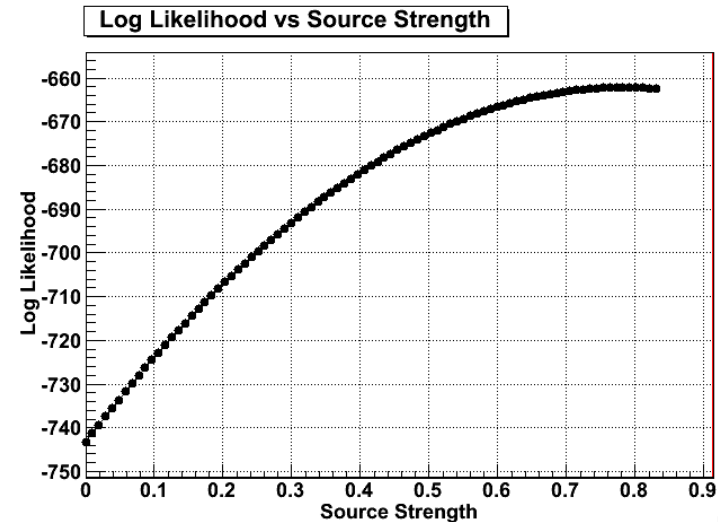

Different datasets

- Additionally can use “statistical separation power” (Punzi, 2006) as a metric for the modulation pattern to be identified above background

$$s = \frac{\sigma_{best}(f)}{\sigma(f)} = \sqrt{f(1-f) \int \frac{(p_1(x) - p_2(x))^2}{p_{tot}(x|f)}}$$

Dependent on signal/background fraction (f)

- This value can be optimized for an ‘ideal’ modulation pattern

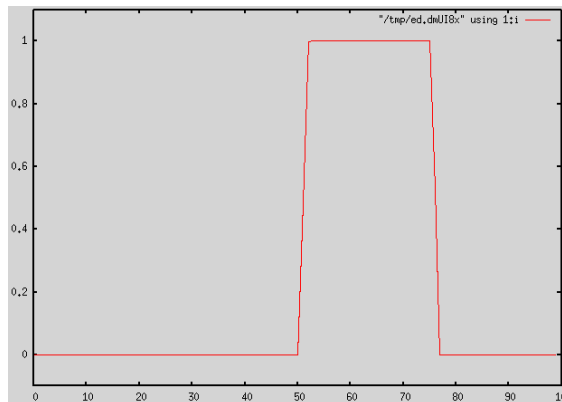
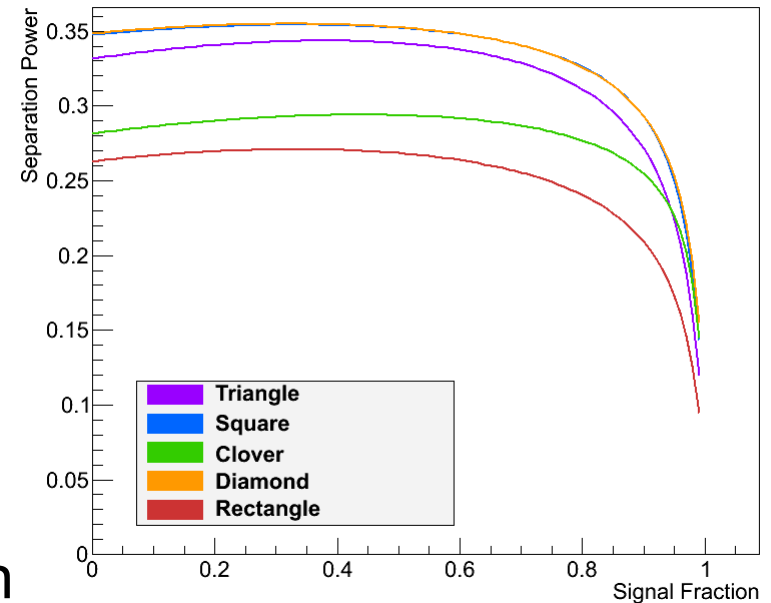

Signal Fraction = 5%
Optimized open fraction = ~27%

- Adding additional passive shielding affects signal fraction and pattern. Can **increase** detection ability.

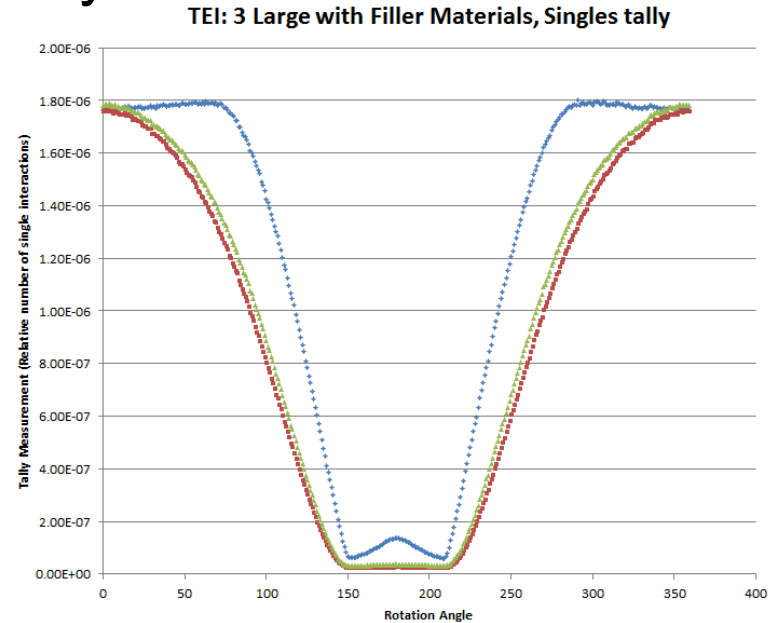
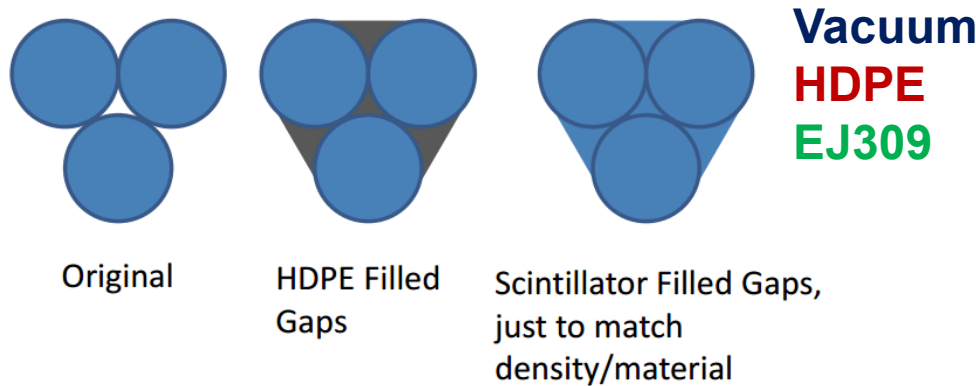

ROC Curve Comparison - Gap Materials

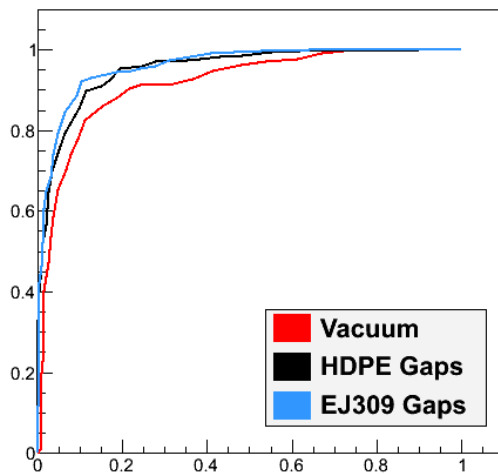

Punzi Separation Comparisons

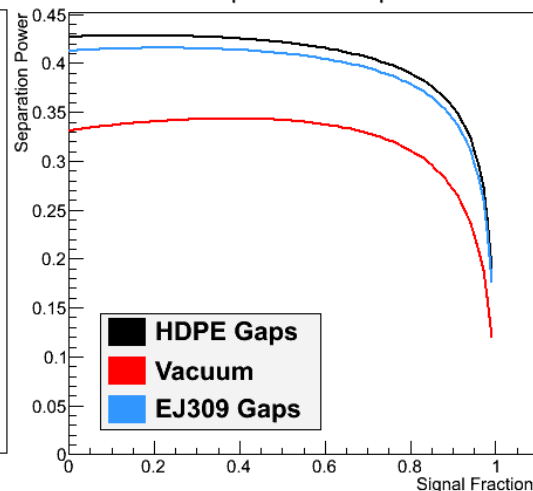

Shielded PRISM Configurations

- Altering the shape of surrounding passive shielding

By adding additional shielding we can match the performance of the best 4-cell configuration which excluded shielding

Next PRISM design includes configurable table for cell and shielding positioning.
Studies / Experiments of 4 shielded 4-cell designs planned

Hexagon 1

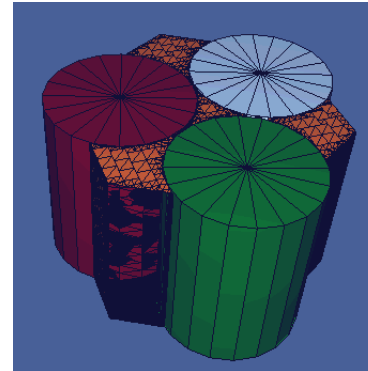

Outer Circle

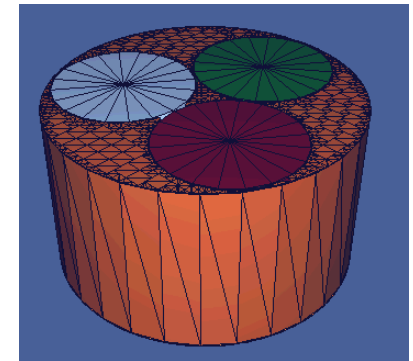

Comparison of TEI Shapes

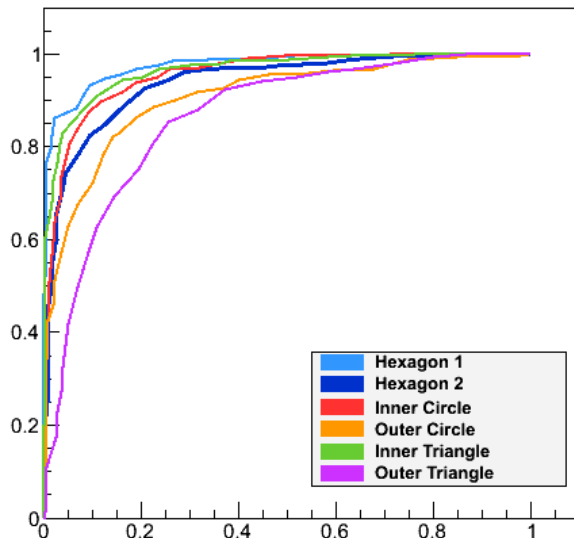

TEI: HDPE Filler, Various geometries

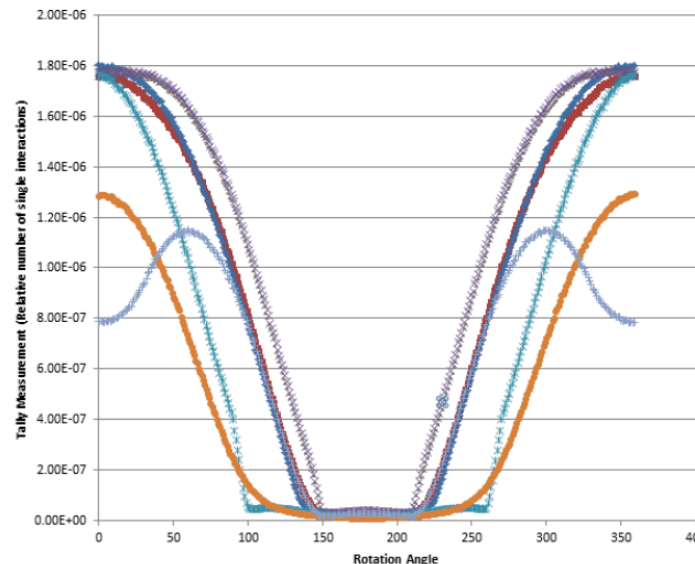

- Hexagon 1
- Hexagon 2
- Inner Circle
- Outer Circle
- Inner Tri.
- Outer Tri.
- Shield Tri.

Large Cell Mechanical Designs

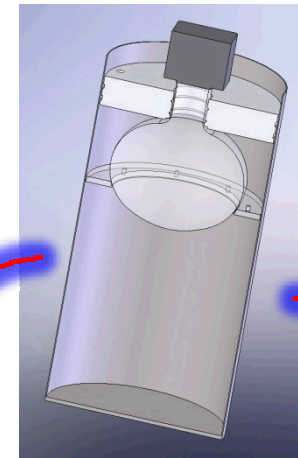
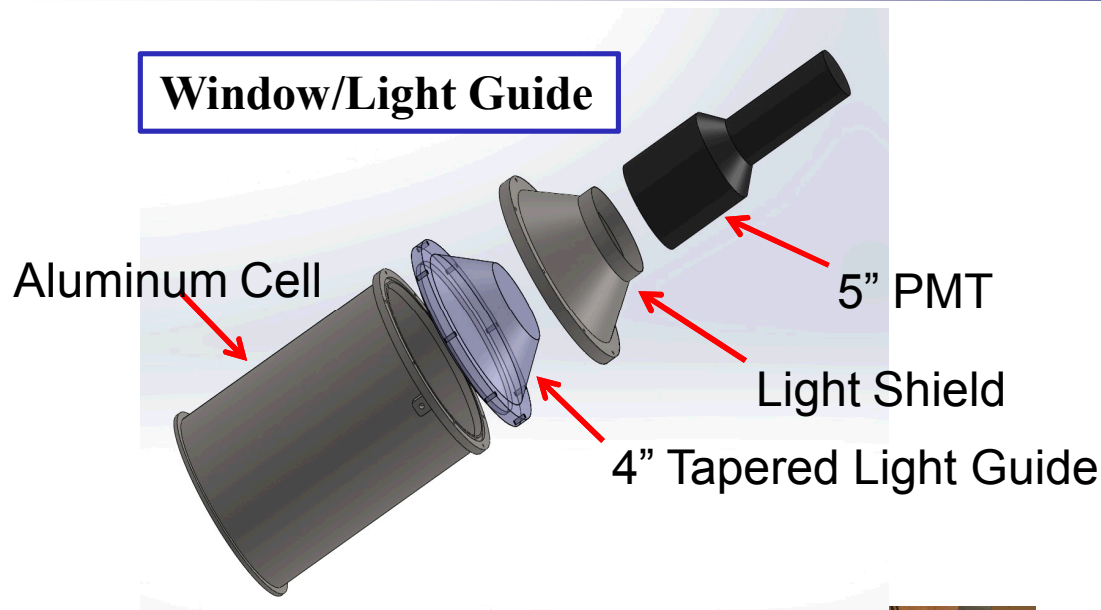

Immersed

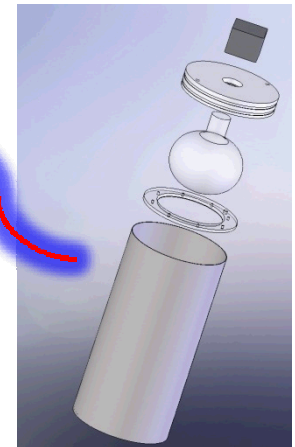

1D TEI

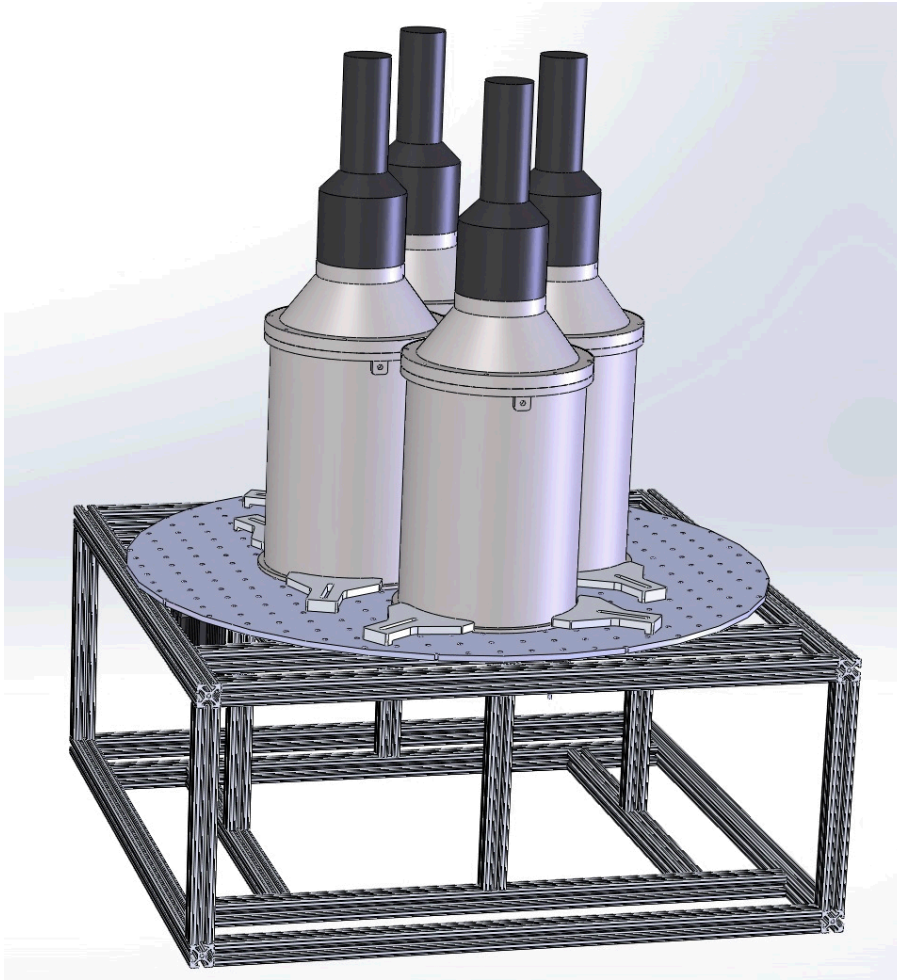

- 4 Aluminum 23 L Cells
- Hamamatsu 5" PMT
- 4" Tapered Light Guide
- 42" Diameter Mounting Table
- Dual Stepper Drive System
- Direct Encoder Position Readout

1D TEI Frame Bottom View

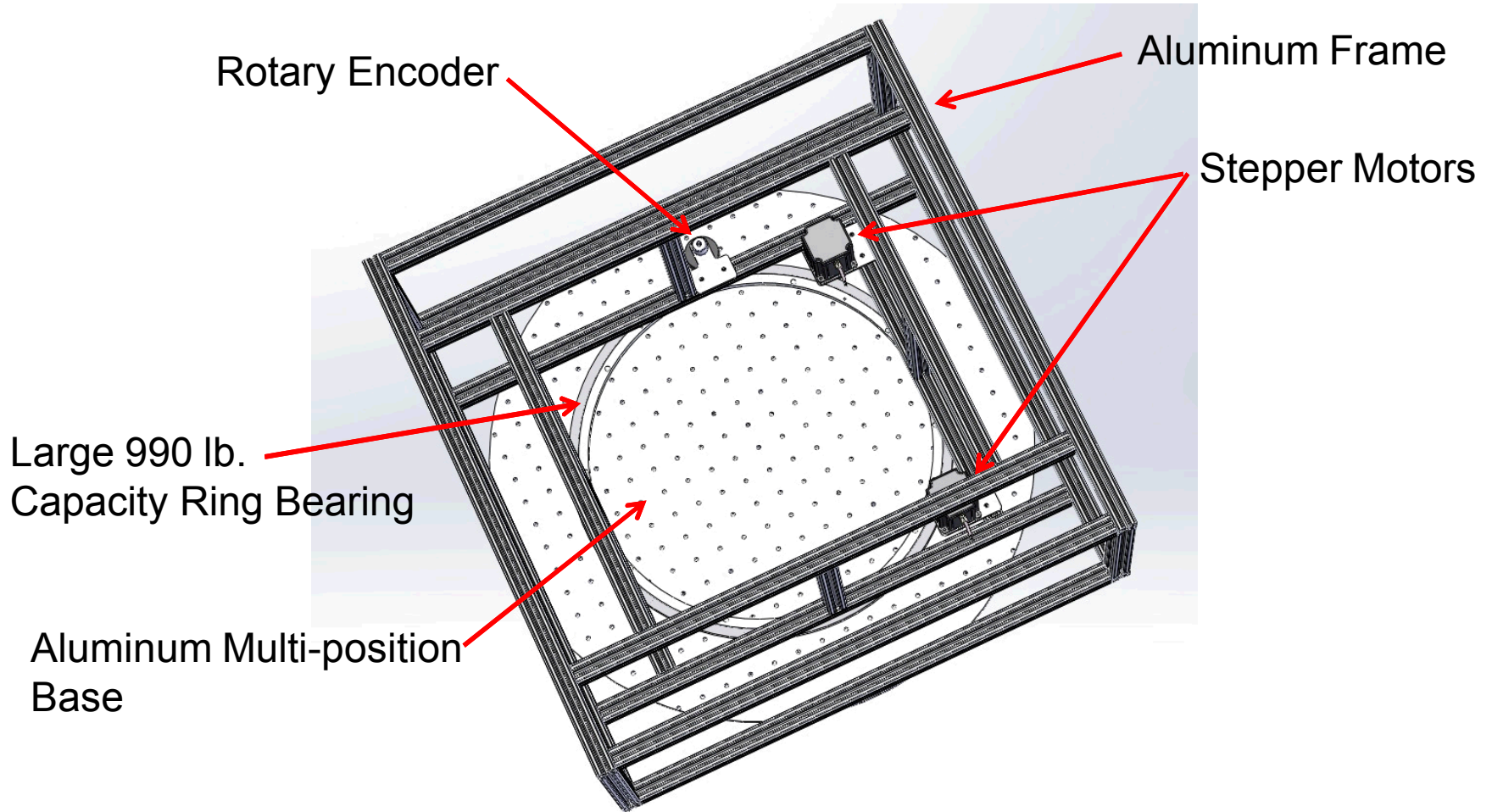

As-built photos

