

LA-UR-

10-04699

Approved for public release;  
distribution is unlimited.

*Title:* DISPOSITION OF TRANSURANIC RESIDUES FROM  
PLUTONIUM ISENTROPIC COMPRESSION EXPERIMENT  
(PU-ICE) CONDUCTED AT Z MACHINE

*Author(s):* Kapil K. Goyal, Los Alamos National Laboratory  
Betty J. Humphrey, Weston Solutions Inc.  
Jeffry Gluth, Sandia National Laboratories, New Mexico  
David M. French, Los Alamos National Laboratory

*Intended for:* 13th International Conference on Environmental Remediation  
and Radioactive Waste Management  
ICEM2010  
October 3-7, 2010, Tsukuba, Japan



Los Alamos National Laboratory, an affirmative action/equal opportunity employer, is operated by the Los Alamos National Security, LLC for the National Nuclear Security Administration of the U.S. Department of Energy under contract DE-AC52-06NA25396. By acceptance of this article, the publisher recognizes that the U.S. Government retains a nonexclusive, royalty-free license to publish or reproduce the published form of this contribution, or to allow others to do so, for U.S. Government purposes. Los Alamos National Laboratory requests that the publisher identify this article as work performed under the auspices of the U.S. Department of Energy. Los Alamos National Laboratory strongly supports academic freedom and a researcher's right to publish; as an institution, however, the Laboratory does not endorse the viewpoint of a publication or guarantee its technical correctness.

**DISPOSITION OF TRANSURANIC RESIDUES FROM PLUTONIUM ISENTROPIC COMPRESSION  
EXPERIMENT (PU-ICE) CONDUCTED AT Z MACHINE (LA-UR-10-)**

**Kapil K. Goyal, Los Alamos National Laboratory**  
**Jeffrey Gluth, Sandia National Laboratories, New Mexico**

**Betty J. Humphrey, Weston Solutions Inc.**  
**David M. French, Los Alamos National Laboratory**

**ABSTRACT**

In 1992, the U.S. Congress passed legislation to discontinue above- and below-ground testing of nuclear weapons. Because of this, the U.S. Department of Energy (DOE) must rely on laboratory experiments and computer-based calculations to verify the reliability of the nation's nuclear stockpile. The Sandia National Laboratories/New Mexico (SNL/NM) Z machine was developed by the DOE to support its science-based approach to stockpile stewardship.

SNL/NM researchers also use the Z machine to test radiation effects on various materials in experiments designed to mimic nuclear explosions. Numerous components, parts, and materials have been tested. These experiments use a variety of radionuclides; however, plutonium (Pu) isotopes with greater than ninety-eight percent enrichment are the primary radionuclides used in the experiments designed for stockpile stewardship. In May 2006, SNL/NM received authority that the Z Machine Isentropic Compression Experiments could commence.

Los Alamos National Laboratory (LANL) provided the plutonium targets and loaded the target assemblies, which were fabricated by SNL/NM. LANL shipped the loaded assemblies to SNL/NM for Z machine experiments. Three experiments were conducted from May through July 2006. The residues from each experiment, which weighed up to 913 pounds, were metallic and packaged into a respective 55-gallon drum each.

Based on a memorandum of understanding between the two laboratories, LANL provides the plutonium samples and the respective radio-isotopic information. SNL/NM conducts the experiments and provides temporary storage for the drums until

shipment to LANL for final waste certification for disposal at the Waste Isolation Pilot Plant (WIPP) in southeastern New Mexico. This paper presents a comprehensive approach for documenting generator knowledge for characterization of waste in cooperation with scientists at the two laboratories and addresses a variety of topics such as material control and accountability, safeguards of material, termination of safeguards for eventual shipment from SNL/NM to LANL, associated approvals from DOE-Carlsbad Field Office, which governs WIPP and various notifications. It portrays a comprehensive approach needed for successful completion of a complex project between two national laboratories.

**INTRODUCTION**

At Los Alamos National Laboratory (LANL), the plutonium facility at Technical Area 55 (TA-55) is the primary generator of transuranic (TRU) waste from operations and research. *TRU waste* contains isotopes with atomic numbers greater than 92, half-lives greater than 20 years, and radioactivity of at least 100 nano-curies per gram of waste. During 2006, three drums of Z machine experimental residues were generated from the experiments and stored at SNL/NM. In 2010, it was concluded that LANL has the controlling responsibility for the TRU waste from the experiments, including the experiment assemblies in the 55-gallon waste drums and responsible for their removal from SNL/NM and eventual disposal at WIPP.

The experimental setup is depicted by Fig. 1 - 4. Figure 1 illustrates the location of four samples of plutonium in each target assembly for each experiment. Each one of the three experiments had its own target. Each target had four samples of plutonium arranged inside a diagnostic holder. The

cumulative plutonium amounts of the three targets are 1.345, 1.414, and 3.3838 grams per experiment.

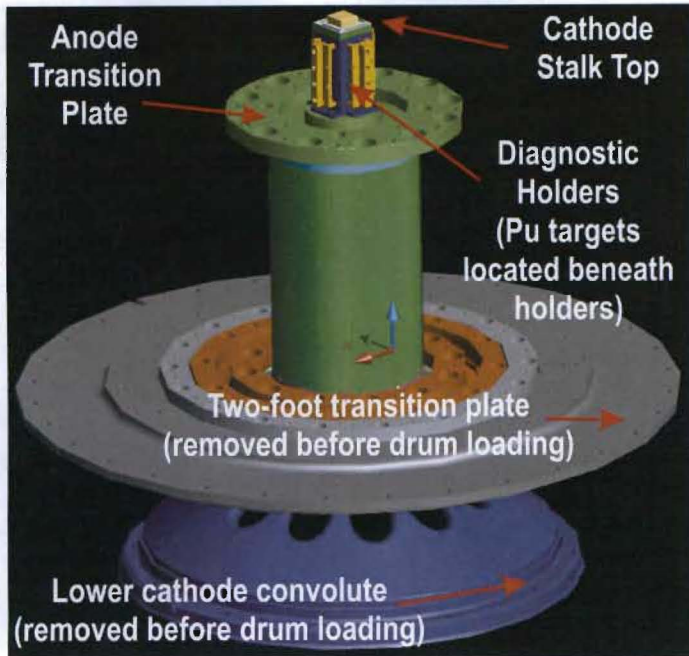

**FIG. 1: PLUTONIUM TARGET LOAD ASSEMBLY FOR EACH EXPERIMENT**

Figure 2 illustrates the Ultra-Fast Closure Valve and Detonation Gases Vent Tank used in the experiment.

The experiment is conducted by subjecting the plutonium targets to a momentary burst of extreme heat and pressure in the Z machine.

The SNL/NM dynamic materials team, in collaboration with experimenters from LANL, conducts high pressure experiments using the Z machine pulsed power system and gas guns. Pressures range from 10 kilobar up to 15,000 kilobar and the operating temperatures reach from 270 to 2000 degrees Kelvin. Laser diagnostics from Class III to the Z-Beamlet laser and other high voltage systems are utilized. SNL/NM researchers also use the Z machine to test radiation effects on various materials in experiments designed to mimic nuclear explosions. Numerous components, parts, and materials have been tested. Such intense momentary burst of intense heat and pressure completely oxidize organics used in the assembly of the experiment and plutonium is alloyed into the metal matrix surrounding the targets.

The experimental residues stay in the upper containment chamber (UCC) and the gases are vented to the atmosphere through high-efficiency particulate adsorption (HEPA) filters as shown in Fig. 3.

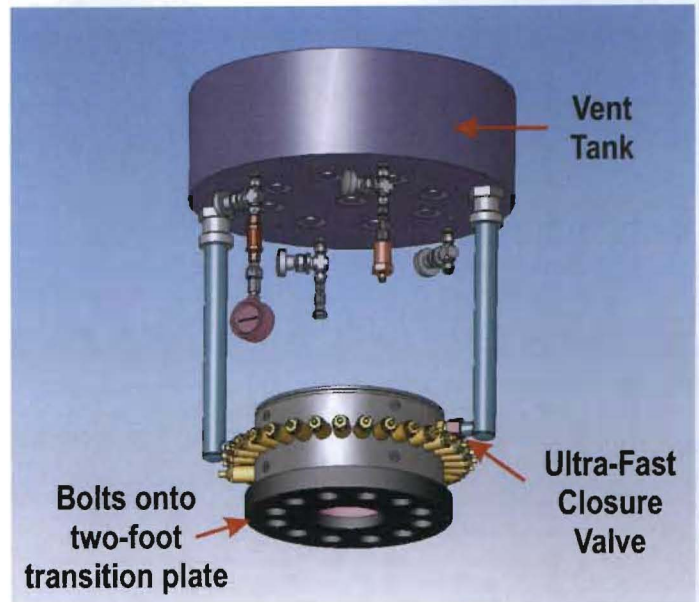

**FIG. 2: ULTRA-FAST CLOSURE VALVE AND DETONATION GASES VENT TANK**

Figure 4 shows relative locations of components used in Fig. 2 and 3 and the post experiment residues containment system emplaced inside a 55-gallon drum. The target assembly of Fig. 1 is located inside the UCC of Figure 3 and this combined unit is situated between the Ultra-Fast Closure Valve and Detonation Gases Vent Tank of Fig. 2.

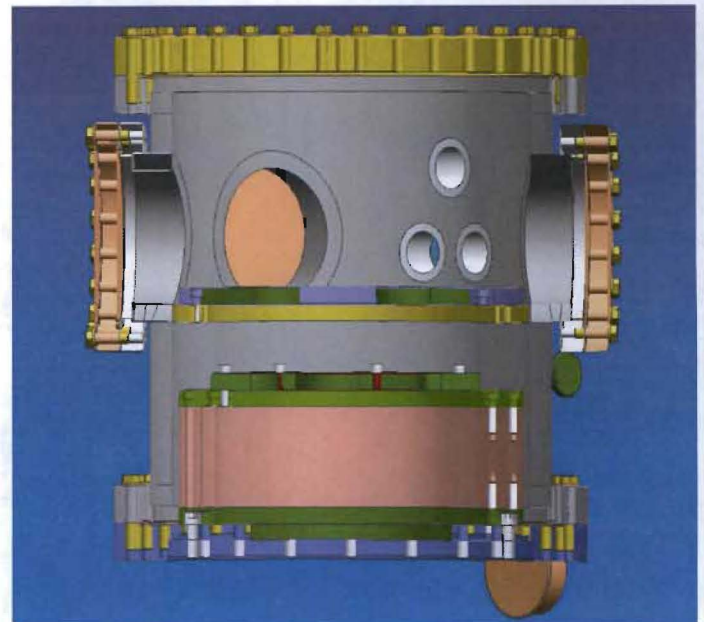

**FIG. 3: UPPER CONTAINMENT CHAMBER**

Between 2006 and February 2010, representatives from both laboratories discussed the appropriate management options of the alloyed plutonium leftover in the three experimental assemblies as either material or material in excess of any future programmatic needs (i.e., waste). LANL scientists, in

conjunction with The Department of Energy Los Alamos Site Office (LASO), and SNL/NM, determined after a detailed analysis that the leftover alloyed plutonium in the surrounding metal matrix was no longer needed for any programmatic purpose, and thus, determined to be TRU waste.

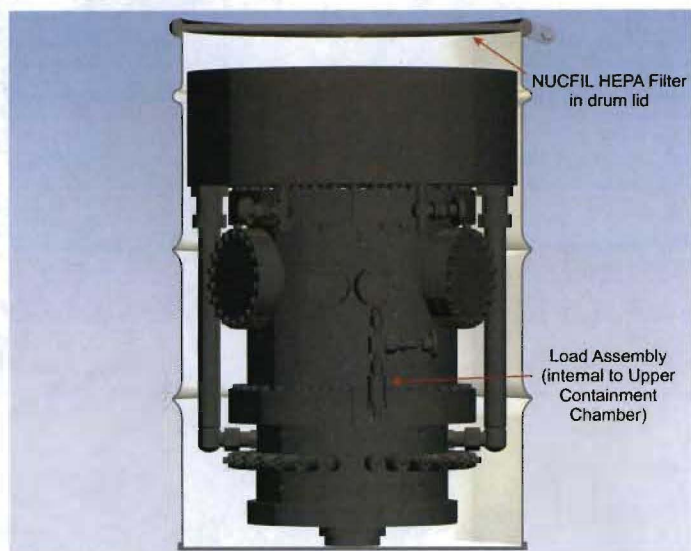

**FIG. 4: CONCEPTUAL DRAWING OF A CONTAINMENT SYSTEM WITHIN A 55-GALLON DRUM.**

Both options offered their advantages and limitations. Managing the drums as material seemed an easy task on the surface but had challenges associated with finding Type B containers for enclosing the drums, shipping them on public highways, and notifying the governors of western states. A need to conduct a total of 30 similar experiments had already been identified and sanctioned by DOE. Therefore, extensive use of material shipments was deemed questionable because of public perceptions.

Managing the drums as waste also allowed the drums to be transported in a large Type B container that accommodates 14 TRU waste drums. This type of container, known as TRUPACT-II, is routinely used for TRU waste shipments from LANL to WIPP. While shipment of TRU waste drums directly from SNL/NM to WIPP is not permitted because SNL/NM does not have a WIPP certified program, shipment of TRU waste drums from SNL/NM to LANL is a viable option under the existing regulatory framework. The option to ship the drums as waste to LANL had its own challenges. From an off-site facility, LANL is not permitted to receive any TRU waste with hazardous constituents identified per Resource Conservation and Recovery Act (RCRA). To proceed further, LANL had to ascertain that RCRA regulated constituents would not be present (or if they were present, their concentration had to be below the regulatory threshold). In the containment system, the experiment used small amounts of lead (Pb), a RCRA regulated metal for toxicity, and epoxy that could contain benzene, another regulated organic. The discussions between the two laboratories led to a decision that a comprehensive analysis regarding characterization of the waste

was essential much the same way all other waste was characterized at LANL. A comprehensive generator knowledge (GK) report was prepared during 2010 to document the characterization.

Additionally, both laboratories needed a path forward for drum movement prior to conducting future experiments mentioned above. Consequently, the program managers required a comprehensive plan for residue shipments from SNL/NM to LANL. The need to address disposition of residues from failed experiments was also identified.

## GENERATOR KNOWLEDGE REPORT

For accurate waste characterization, TA-55 routinely uses GK. This characterization is a systematic approach for documenting the physical, radiological, and chemical characteristics of waste. It relies on investigating and documenting the history of each item used in the experiment; understanding the process that generates the waste; interviewing researchers, engineers, scientists, or technicians who are thoroughly familiar with the experimental details and documenting testimonials with their signatures; reviewing manufacturer supplied material safety data sheets (MSDS) for each constituent of the experiment; corresponding specifically with manufacturers if the MSDS would be inadequate; and reviewing the entries of laboratory logbooks or notebooks for experimental data. Of particular concern was the presence of any chemical which would carry an Environmental Protection Agency (EPA) Hazardous Waste Number (HWN) because LANL's permit from the State of New Mexico prohibits receipt of non-LANL radioactive waste contaminated with RCRA regulated constituents.

## Physical and Radiological Characteristics

This waste stream is composed of Pu-ICE post-shot containment systems. These systems are manufactured or fabricated items that are in compliance with documented specifications from suppliers qualified under well-established quality programs. The plutonium targets, with certified isotopic compositions, are fabricated by LANL. The other experimental system is fabricated at SNL/NM. Both laboratories follow strict quality assurance (QA) and quality control procedures.

The containment systems are 99.6% metallic (97.2% ferrous, 2.4% non-ferrous) and contain gram values of actinide isotopes, predominantly plutonium-239 with greater than 93% in its isotopic distribution. This waste stream meets the Pu limits of the WIPP Waste Acceptance Criteria (WAC). The remaining 0.4% of constituents are rubber, plastics, other organics e.g., epoxy that is suspected to contain benzene. Only 17.1 gram (g) of lead is contained in the entire containment system. The gram values of plutonium samples mentioned earlier were measured by calibrated mass balances.

## Resource Conservation and Recovery Act (RCRA) Regulated Hazardous Constituents

Because the containment systems are manufactured to documented and approved specifications, the material and chemical content of the waste stream is well known and discussed as the following:

### *Hazardous Waste from Non-specific Sources with Industry and EPA Hazardous Waste Numbers or F Listed Waste*

This waste stream does not contain any F-listed solvents regulated under the Code of Federal Regulation (CFR) 40 CFR §261.31 as hazardous waste from non-specific sources. Ethanol and alcohol are used to clean surfaces prior to assembly of the containment systems. However, these compounds are not absorbed into the containment systems and, therefore, are not RCRA-regulated concerns.

### *Hazardous Waste from Specific Source (K-listed), Acute (P-listed) or Discarded or Unused and Unspent Chemicals (U-listed)*

This waste stream is not hazardous waste from any of the specific sources identified in 40 CFR §261.32. No K-listed codes apply.

This waste stream is not mixed with a discarded commercial chemical product, nor off-specification commercial chemical product, nor any container residue thereof identified in 40 CFR §261.33. P or U listed codes are not applicable.

### *Characteristic Waste for Toxicity*

This waste stream does not contain RCRA-regulated organic constituents in concentrations that would qualify it as toxicity characteristic hazardous waste under 40 CFR §261.24 (44). Based on a review of the procedures, material feed, and interviews with the subject matter experts (SME) for the experiment, a comprehensive list of chemicals and constituents was developed. Only two suspect items — benzene in epoxy and lead in lead-bearing materials — were concerns. Their presence is addressed as follows:

*Epoxy* is used in the fabrication and assembly of the containment systems. At LANL, two epoxy products are used in the manufacture of the plutonium targets. One of the epoxy products contains benzene, which is included as a toxicity characteristic compound in 40 CFR §261.24. This epoxy product was evaluated for the concentration of benzene and found to contain this regulated constituent in a concentration below the RCRA regulatory level. In addition, benzene would not be present in cured epoxy due to its volatility; moreover, all organics in the target assembly are destroyed during the experiments due to the high heat associated with the experimental process. Therefore, organic compounds are not present in the target assembly of the final waste form.

At SNL/NM, two epoxy products are used in the manufacture and assembly of the Pu-ICE containment systems. These

epoxy products were evaluated for the presence of RCRA-regulated constituents and it was determined that regulated constituents were not present in the cured product and so would not result in a hazardous waste listing. This information was obtained from the MSDS and discussions with the manufacturer.

*Lead* is present below the regulatory threshold and would not qualify as a toxicity characteristic hazardous waste under 40 CFR §261.24. The containment system includes components that contain lead which is included as a toxicity characteristic compound in 40 CFR §261.24, Table 1. An evaluation of the total lead content in the brass, piezoelectric actuators (PZT), and solder found in the containment system determined that 17.1 g of lead are present. A conservative estimate of the total lead concentration can be determined by dividing the mass of lead by the lowest mass of the three containment systems to date, as follows:

Total mass of lead in the containment system = 17.1 g  
Minimum containment system mass = 807 pounds or (366,378 g); therefore:

$$(17.1 \text{ g of Lead}) / (366,378 \text{ g total mass})$$

$$= 0.000047 \text{ part per part or 47 parts per million (ppm) as total lead.}$$

Based on this calculation, the total lead concentration in a Pu-ICE post-shot containment system is 47 ppm, which is well below the RCRA regulatory level of 100 ppm for a totals evaluation. Note that this evaluation is based on a totals analysis, and so the RCRA regulatory level for lead is 20 times the regulatory level for leachable lead shown in 40 CFR §261.24, Table 1. The EPA allows totals analysis as a conservative way of determining whether or not items are considered hazardous waste when disposed. This number will change up or down based on weight of the new containment systems and the changes in the components.

*Acceptance criteria Prohibited Items: compressed gases, free liquids, nonradionuclide pyrophorics, sealed containers greater than four liters, explosives, greater than 1% radionuclide pyrophorics and polychlorinated biphenyls (PCB)*

Based on interviews and procedure reviews, no such constituents are present.

*Sealed containers greater than four liters in volume* are prohibited because of the explosive nature of hydrogen which is generated from radiolytic decay of organics or hydrogenous materials. The experiment's residues conform to Waste Material Type II.2, Solid Inorganic Materials, per Trupact Authorized Methods for Payload Control (TRAMPAC) and are packaged in metal containers (55-gallon drums). Ferrous and non-ferrous metals make up 99.6% of the mass. In accordance with the current revision of the Contact Handled (CH) TRAMPAC, there is no prohibition of sealed containers greater

than 4 liters in volume for Waste Material Type II.2 because it does not generate any flammable gases. Furthermore, there are no sealed containers greater than four liters in volume in this waste stream. Two components of the containment systems, the vent tank and the UCC, are greater than four liters in volume but they are unsealed. Gases are captured in the vent tank during the experiments. The vent tank and the UCC are fitted with valves to relieve the pressure. The valves are opened and read zero residual pressure as the tank and the UCC are opened to the atmosphere before packaging in the 55-gallon drum. This is documented with videotapes for the residues in the current inventory. Figure 5 shows the gages at no residual pressure.



**FIG. 5: PRESSURE GAGE AT ZERO.**

Figure 6 shows there is neither residual vacuum nor pressure in the valve left in open position.



**FIG. 6: VACUUM/PRESSURE GAGE AT ZERO DOCUMENTING OPEN VALVE.**

## COMPREHENSIVE PLAN REPORT

The purpose of the comprehensive plan was multi-fold. It addresses the various issues other than characterization for successful shipment of drums from SNL/NM to LANL. Not only does it identify the need to prepare a GK report and maintenance of the GK for future experiments, it addresses the three scenarios of failed experiments. It also documents the steps necessary to terminate safeguards, timing of safeguard termination, ensuring future residues comply with LANL generated waste profile form when residues are declared waste, requirements for successfully obtaining a TRUPACT II for packaging drums for shipment, estimate of costs that would be incurred for individual tasks, responsible entities, and future process enhancements, e.g., deployment of certified visual examination of experimental setup. For successful completion of the GK and comprehensive plan report, LANL staff conducted weekly teleconferences among representatives from the two laboratories, their governing DOE site offices, and the LANL satellite office at Carlsbad, and they also maintained a weekly progress Gantt chart to ensure staff commitment and timely completion of various tasks and documents.

### *Failed Experiment*

There are three possible scenarios for a failed Pu-ICE experiment discussed below:

1. The machine pre-fire causes the control system to initiate the detonators and closes the valve
2. A valve closure failure or breach of the containment chamber causes contamination inside of the Z machine center section, and
3. A rejected incoming shipment of the load/target caused by damage in transit and contamination of the inner container.

Each of these scenarios is under evaluation by SNL/NM and contingency planning is ongoing. In the event of a failed experiment under any scenario, SNL/NM will determine the necessary actions and resources to remove the containment system from the Z machine. LANL and SNL/NM will cooperatively determine the necessary actions and resources needed to manage the associated waste, and manage the nuclear material, as applicable. At that time, the GK Report will be updated to reflect the failed experiment scenario and to revise the waste management and material management activities.

## RESULTS AND CONCLUSION

LANL, as the owner of the residues, through DOE-LASO, has submitted the GK report to DOE Carlsbad Field Office (CBFO) that owns and operates the WIPP facility. LASO has requested that CBFO prepare authorizing documents for waste specific TRAMPAC so that a TRUPACT II and a mobile loading unit is deployed for drum shipment from SNL/NM to LANL and authorize a certified visual examination for future experiments to ensure compliance with the requirements of sealed

containers greater than four liters in volume. CBFO decision and direction is expected in the near future.

The Laboratory personnel believe that upon successful shipment for the existing three drums, the future shipments would become a routine activity. The experience gained from these interactions bodes well for future cooperative experiments involving the two laboratories and sets the tone for similar cooperative experiments with DOE laboratories or facilities.

## ACKNOWLEDGMENTS

I am grateful to our managers Alison Dorries, Scotty Jones, and Robert Dodge for supporting this project and allowing me to coordinate planning functions for multidisciplinary staff to ensure that the management of experimental residues complies with all WIPP certification requirements and Department of Transportation regulations.

I feel privileged for having worked with the program sponsors Rick Martineau and William Hamilton of Los Alamos National Laboratory and Stan Haynes and Jeffry Gluth of SNL/NM who entrusted me with this project.

For their expert consultation, I am thankful to Liza Tafoya for safeguard and security topics; Randy Fitzgerald, Technical Specialists, LLC and Jeff Carmichael of LANL for environmental regulations and characterization criteria per individual permits for LANL or WIPP; Sherry Willis for conducting generator interviews for waste characterization; and Andrew Worker of LASO and Jody Pugh of DOE-Sandia Site Office for continued interest or needed governmental actions.

Many thanks to Tom Krause of TJK Consulting for investigating myriads of technical details and Robert K. Staudhammer and Louise Mendius for their efforts in editing.

## REFERENCES

There are 63 references cited in the GK report and 34 in the comprehensive plan. The key references for this paper are:

1. *Generator Knowledge Report for the Plutonium Isentropic Compression Experiments Containment Systems*, FFS-RPT-001, Los Alamos National Laboratory, Los Alamos, New Mexico.
2. *Comprehensive Plan for the Shipment of Plutonium Isentropic Compression Experiments (Pu-ICE) Containment Systems from Sandia National Laboratories/New Mexico to Los Alamos National Laboratory, Revision 0, May 5, 2010*, Los Alamos National Laboratory, Los Alamos, New Mexico.
3. Los Alamos National Laboratory, *Waste Management Requirements*, TA55-RD-539, April 2009.