

10
11/18/94 JSD

Don. G.

RF Feedback Development for the PEP-II B Factory*

P. Corredoura, L. Sapozhnikov, R. Tighe

Stanford Linear Accelerator Center, Stanford University, Stanford, CA 94309, USA

Abstract

In PEP-II heavy beam loading along with a relatively long revolution period combine to strongly drive lower coupled-bunch modes through interaction with the fundamental cavity mode. Feedback techniques can be applied to reduce the cavity impedance seen by the beam. Several RF feedback loops are planned to reduce the growth rates down to a level which can be damped by the relatively low power bunch-by-bunch longitudinal feedback system[1]. This paper describes the RF feedback loops as well as hardware tests using a 500 kW klystron, analog and digital feedback loops, and a low power test cavity.

1. INTRODUCTION

Longitudinal coupled-bunch oscillations are driven by the difference in the real impedance seen by the beam at the synchrotron sidebands of the mode in question. In the PEP-II low energy ring (LER), beam revolution harmonics spaced by only 136 kHz combine with a large detuning angle to produce a situation where the fundamental cavity resonance crosses a beam harmonic as the ring is filled (figure 1).

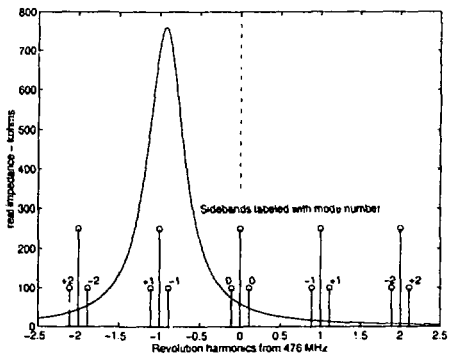

Fig. 1. Cavity impedance, revolution harmonics with sidebands

$$\frac{1}{\tau} = \frac{I_0 \eta}{2V_s \beta^2 \frac{E}{e}} \sum f_{cb} R_{cb}$$

equation 1:
growth rate expression

I_0 = average dc beam current
 η = momentum compaction
 β = particle velocity factor
 E = particle energy
 e = electron charge
 f_{cb} = mode frequency
 $R_{cb} = Re(Z_{upper} - Z_{lower})$

For each mode, there is a sideband below the related beam harmonic and one above. Positive impedance at the lower side-

band damps the particular mode while impedance at the upper sideband drives instability. The difference of the two impedances determines the growth rate (equation 1)[2]. The objective of adding feedback loops is to reduce by a factor 200 the real portion of the loaded cavity impedance observed by the beam.

2. RF FEEDBACK LOOPS

The direct RF feedback loop operates at the RF system frequency (figure 2)[3]. A sample of the cavity field from a cavity probe is simply scaled and phase shifted to provide the proper open loop transfer function. A RF hybrid functions as the summing node. Assuming the klystron has more bandwidth than the feedback loop, the cavity resonance and the system group delay (including klystron) determine the loop characteristics. The effectiveness of this loop is limited by the system delay. Loop gain is limited since poor phase margins actually cause an increase in the real portion of the closed loop cavity impedance where the loop gain crosses unity. For this reason, the 1.2 MW klystron being developed is designed for a short group delay of <150 ns. The anticipated total system group delay in PEP-II is ~350 ns allowing for a loop gain of 8 and a bandwidth of 800 kHz.

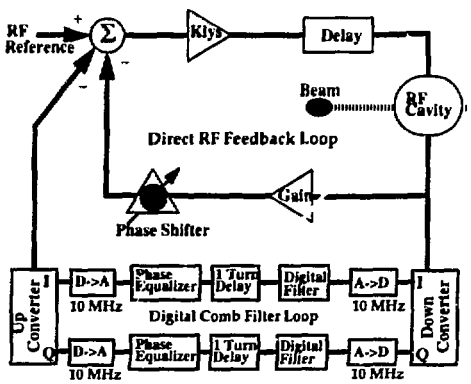

Fig. 2. Block diagram of direct and comb filter RF feedback loops

The comb filter loop operates outside the first loop and sees the cavity resonance which has been damped by the direct loop[3]. The goal of the comb loop is to provide additional feedback, but only at the locations of the synchrotron sidebands. The cavity probe signal is mixed down to baseband into two channels. One channel contains the in-phase information (real part) and the other containing the quadrature information (imaginary part). Each channel is sampled at 10 MHz and processed digitally.

*Work supported by Department of Energy, contract DE-AC03-76SF00515

MASTER

DISTRIBUTION OF THIS DOCUMENT IS UNLIMITED

The comb filter transfer function lends itself to an IIR implementation[3][4]. Because of the relatively large synchrotron tune in PEP-II, a dual-peak comb filter will be used (equation 2). The transfer function includes a near 1-turn delay. The exact

$$\frac{G(Z^{-70} - Z^{-144})}{1 - 2K\cos(2\pi Q_s)Z^{-74} + K^2Z^{-148}}$$

Equation 2: dual peak comb filter transfer function

G = forward gain
 Z^{-74} = 1 turn
 Q_s = synchrotron tune
 K = reverse gain

length of this delay is adjusted to compensate for the system group delay so that corrections are applied on the next turn.

The system delay is not constant over a wide bandwidth. The highest delay is caused by the damped cavity resonance, hence the group delay is greatest in the bandwidth covered by the direct loop. A digital delay equalizer filter is used to compensate for the delay variation, allowing maximum gain in the comb loop. A Harris HSP43168 single clip FIR filter is used to implement the 16 tap transversal filter used in each baseband channel. Tap weights are determined using the measured open loop response of the comb loop path and applying a filter optimization function in MATLAB to linearize the phase response. Equalizer outputs are then converted back to analog signals, up-converted to 476 MHz, summed with the direct loop output, and subtracted from the RF reference in the hybrid before entering the klystron and finally the RF cavity.

3. TEST PROCEDURE

To evaluate loop performance, a test system was developed using development feedback hardware, a 500 kW klystron and a low power test cavity. The objective was to reduce growth rates of the low order longitudinal coupled-bunch modes which are strongly driven by the interaction of the beam with the accelerating mode of the RF cavity. A method was needed to measure the real part of the cavity impedance. The procedure used was to substitute the beam in figure 2 with a HP8753 vector network analyzer. The low power test cavity is an aluminum pill box which has the same loaded Q expected for the high power cavity in development. All four probes were lightly coupled to the cavity to preserve the Q. Two of the cavity probes were used for the impedance measurement, one to inject a swept RF signal into the cavity and one to measure the resulting cavity signals while the feedback loops operated. The klystron was also producing CW power at 476 MHz during the test to simulate actual operating conditions, although the initial testing was done while the tube operated far from saturation. This allowed comparing results to linear models. Future tests will explore saturation effects as the tube is operated near full power.

The cavity was detuned for the worst case: peak resonance at the upper sideband corresponding to the -1 longitudinal coupled-bunch mode sideband at 475.869 MHz (figure 1). The network analyzer was calibrated to measure the real part of the cavity transfer function, and the data could then be scaled to the loaded shunt impedance anticipated in the high power cavity. Since the peaks of the comb filter response are narrow, 1601 measurement points were used over a 2 MHz bandwidth to obtain a resolution of 1.25 kHz. As feedback loops were evaluated, data was transported to a MATLAB program to scale the

impedance and determine the driving impedance for each mode.

4. TEST RESULTS

Beginning with the direct RF feedback loop, the open loop response was measured while the gain and phase shift were adjusted. Figure 3 shows the measured open loop response and indicates the system group delay is ~620 ns. This large delay is mostly attributed to the klystron (350 ns) and the solid state drive amplifier (140 ns). Since the effectiveness of the direct loop is determined by the delay, the RF feedback test configuration represented a more difficult system than anticipated in PEP-II where the total delay will be ~350 ns.

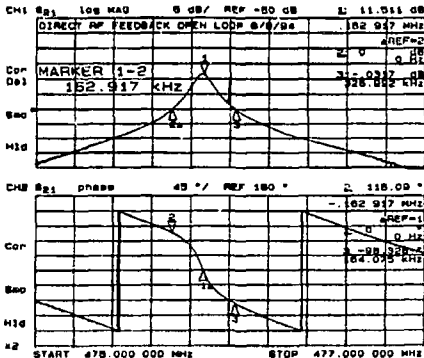

Fig. 3. Measured open loop response of the direct RF feedback loop

After closing the direct feedback loop, the equalizer tap weights needed to be determined. We used the network analyzer to measure the open loop response of the comb feedback path. Both sets of digital filters were removed for the measurement and the A-D outputs were simply connected to the D-A inputs. This enabled us to directly measure the phase response over the entire nyquist frequency range. Figure 4 shows the optimized equalizer tap weights used.

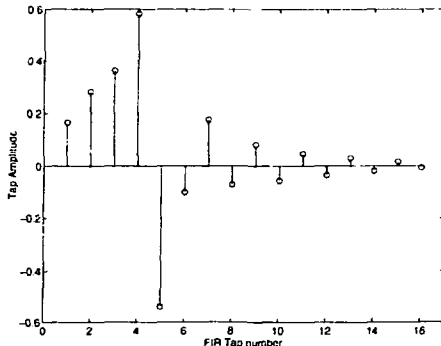

Fig. 4. Group delay equalizer tap weights used

The chosen baseband filter topology contains no cross terms, therefore negative frequencies are filtered identically as positive frequencies. The MATLAB procedure used to calculate the taps averages the positive and negative baseband phase response. The error introduced by this procedure is only 20 degrees over the effective bandwidth of the comb loop. The group delay variation was reduced from 600 ns to 200 ns (figure 5).

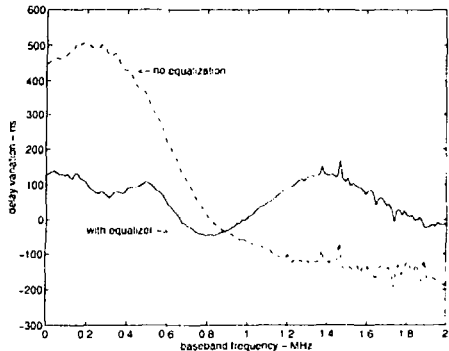

Fig. 5. Baseband group delay before and after equalization

Next the comb filters, group delay equalizers, and near 1-turn delay were configured. The open loop response was measured using the network analyzer. By observing the phase margins across the 2 MHz frequency band of interest, the loop gain, loop phase, and the length of the near 1-turn delay were optimized. We were able to obtain 18 dB of loop gain with a minimum phase margin of 55° over a 2 MHz bandwidth (figure 6).

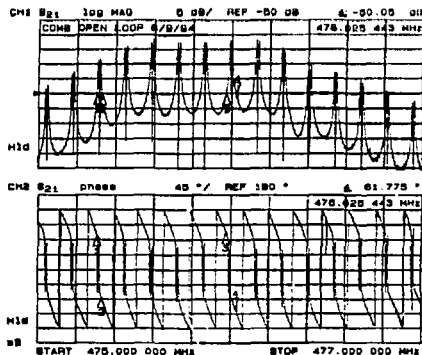

Fig. 6. Measured open loop response of the comb filter loop

The closed loop real cavity impedance with no feedback, direct feedback and direct/comb feedback is plotted in figure 7. The direct loop reduced the peak impedance from 760 kΩ to 180 kΩ. We expect to achieve twice this reduction in the actual PEP-II installation due to shorter group delay. The comb loop, operating on the impedance remaining after damping by the di-

rect loop, reduced the maximum impedance to 18 kΩ. The driving impedances for each mode with both loops operating are plotted in figure 8. All driving terms were reduced to <10 kΩ. The bunch-by-bunch feedback system planned for PEP-II can damp driving terms of 4 kΩ/cavity. The shorter delay of the actual system along with the plan to use the ring RF systems as kickers for the low frequency output of the bunch-by-bunch system should control low order longitudinal coupled-bunch instabilities.

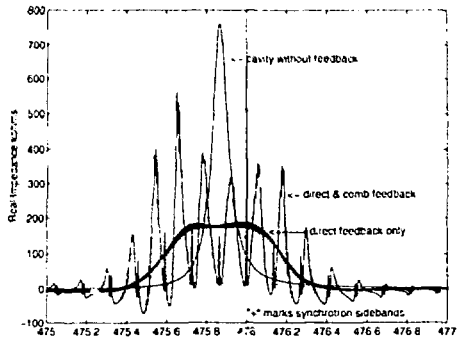

Fig. 7. Measured cavity impedance with direct and comb feedbacks

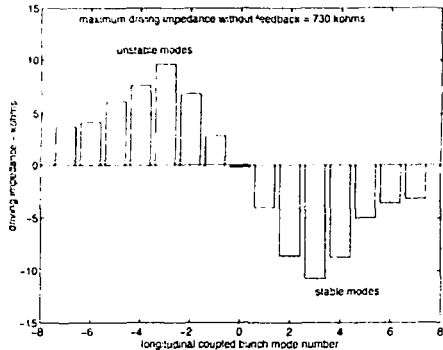

Fig. 8. Measured driving impedances for longitudinal modes -7 to +7

5. REFERENCES

- [1] J. Fox et al, "Feedback Control of Coupled-Bunch Instabilities", Proceedings of the 1993 IEEE Particle Accelerator Conference, 1993.
- [2] S. T. Craig, "RF Cavity Control System for the PEP-II B Factory", Chalk River Laboratories, report #AEL-10776, February 1993.
- [3] F. Pedersen, "RF Cavity Feedback", B Factories - The State of the Art in Accelerators, Detectors, and Physics", SLAC-400, November 1992, pp. 192-207.
- [4] D. McGinnis and J. Crisp, development comb filter hardware on loan from Fermilab.

DISCLAIMER

This report was prepared as an account of work sponsored by an agency of the United States Government. Neither the United States Government nor any agency thereof, nor any of their employees, makes any warranty, express or implied, or assumes any legal liability or responsibility for the accuracy, completeness, or usefulness of any information, apparatus, product, or process disclosed, or represents that its use would not infringe privately owned rights. Reference herein to any specific commercial product, process, or service by trade name, trademark, manufacturer, or otherwise does not necessarily constitute or imply its endorsement, recommendation, or favoring by the United States Government or any agency thereof. The views and opinions of authors expressed herein do not necessarily state or reflect those of the United States Government or any agency thereof.