

DISCLAIMER

This report was prepared as an account of work sponsored by an agency of the United States Government. Neither the United States Government nor any agency thereof, nor any of their employees, makes any warranty, express or implied, or assumes any legal liability or responsibility for the accuracy, completeness, or usefulness of any information, apparatus, product, or process disclosed, or represents that its use would not infringe privately owned rights. Reference herein to any specific commercial product, process, or service by trade name, trademark, manufacturer, or otherwise does not necessarily constitute or imply its endorsement, recommendation, or favoring by the United States Government or any agency thereof. The views and opinions of authors expressed herein do not necessarily state or reflect those of the United States Government or any agency thereof.

Title: Accelerator Transmutation of Nuclear Waste: Towards the Elimination of Long-Lived Radioactive Waste

Author(s): H. J. Dewey

Submitted to: For presentation at the Pyrochemical Workshop to be held in Albuquerque, NM on October 21, 1993

Los Alamos
NATIONAL LABORATORY



MASTER

Los Alamos National Laboratory, an affirmative action/equal opportunity employer, is operated by the University of California for the U.S. Department of Energy under contract W-7405-ENG-36. By acceptance of this article, the publisher recognizes that the U.S. Government retains a nonexclusive, royalty-free license to publish or reproduce the published form of this contribution, or to allow others to do so, for U.S. Government purposes. The Los Alamos National Laboratory requests that the publisher identify this article as work performed under the auspices of the U.S. Department of Energy.

DISTRIBUTION OF THIS DOCUMENT IS UNLIMITED

DISCLAIMER

Portions of this document may be illegible in electronic image products. Images are produced from the best available original document.

September 29, 1993
13th Pyrochemical Workshop
October 18-21, 1993
Albuquerque, NM

**Accelerator Transmutation of Nuclear Waste:
Towards the Elimination of Long-Lived Radioactive Waste**

**Harry J. Dewey
Chemical Science and Technology Division
Los Alamos National Laboratory**

Abstract:

Researchers at Los Alamos have been developing transmutation concepts involving accelerator-driven nuclear systems. A medium energy, high current proton beam strikes a heavy metal target, producing a high flux of spallation neutrons. These neutrons are moderated to near-thermal energies in a blanket surrounding the target. Materials to be transmuted flow through the blanket region where they are fissioned or transmuted to stable nuclides. Stable or short-lived nuclides are separated while the long-lived radioactive species are returned to the blanket. For most applications the fission energy produced is much greater than that required to power the accelerator and can be directed to the commercial power grid.

A number of possible applications are envisioned for accelerator-driven nuclear systems. These include destruction of surplus weapons-grade plutonium, production of tritium, transmutation of commercial spent fuel, and even commercial power generation in next-generation nuclear power plants. Some of these applications will be discussed with particular emphasis on the required chemical separations for such systems.

Accelerator Transmutation of Nuclear Waste: Towards the Elimination of Long-lived Radioactive Waste

Harry J. Dewey

Los Alamos National Laboratory

**13th Pyrochemical Workshop
Albuquerque, NM
October 18-21, 1993**

General Features ATW System

- Driven, sub critical system
- Intense thermal neutron fluxes
- High transmutation cross sections
- Minimal material inventories
- Continuous material feed
- Advanced separations

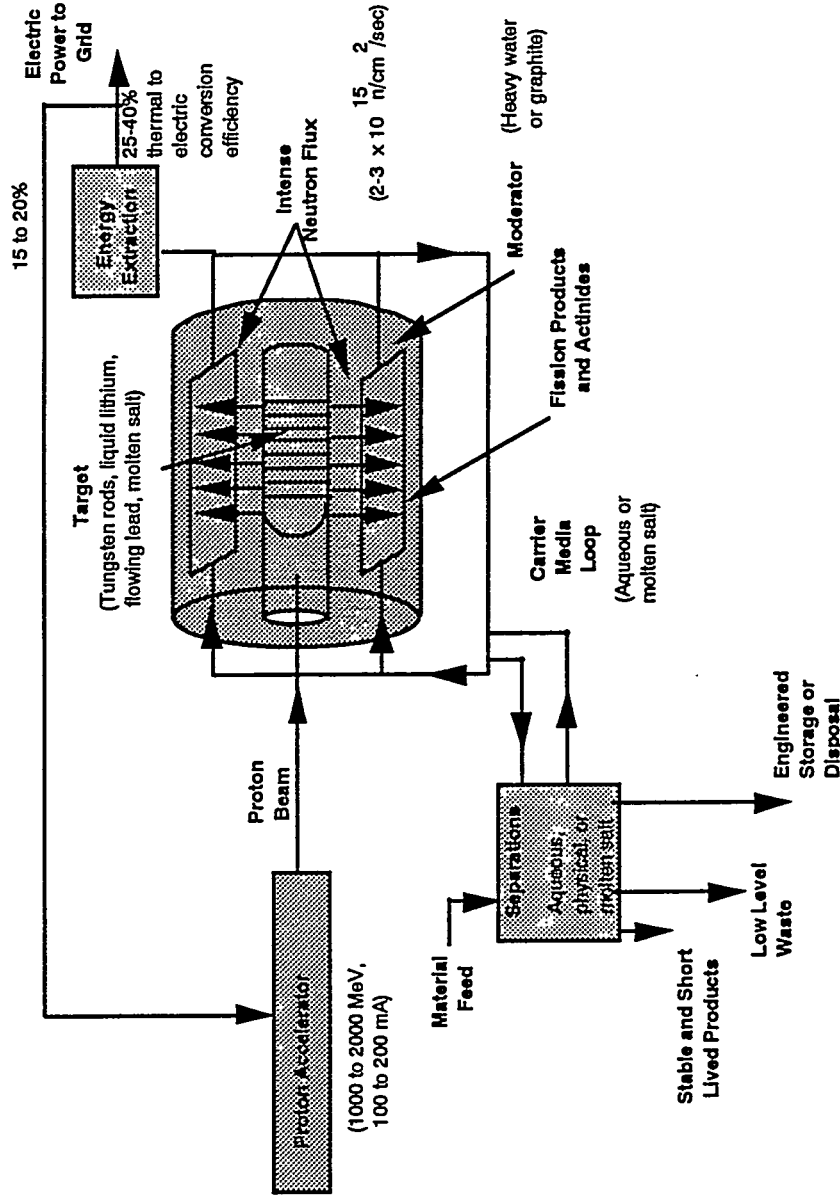

Long-Lived ($t > 30$ yr) Fission Products

Nuclide	Half-Life (years)	Isotopic Abundance	ATW Production Rate (g/kg fissioned)	Capture Cross Section (CANDU) (barns)
^{79}Se	6.50×10^4	11.24%	0.13	1.188
^{93}Zr	1.50×10^6	19.30%	13.75	2.123
^{99}Tc	2.13×10^5	100%	19.94	16.620
^{107}Pd	6.50×10^6	21.21%	15.02	6.760
^{126}Sn	1.00×10^5	40.41%	0.88	0.167
^{129}I	1.57×10^7	72.88%	5.27	15.370
^{135}Cs	2.30×10^6	7.30%	5.09	5.882

Radiation Dose from Contaminated Water from Proposed U.S. Repository is Dominated by Fission Products

<u>Species</u>	<u>Halflife (yrs)</u>
⁹⁹ Tc	213,000
¹²⁹ I	15,700,000
¹³⁵ Cs	2,300,000
²³⁷ Np	2,140,000
²³⁹ Pu	24,100
²⁴⁰ Pu	6,560
²⁴² Pu	375,000
²⁴¹ Am	433
²⁴³ Am	7370

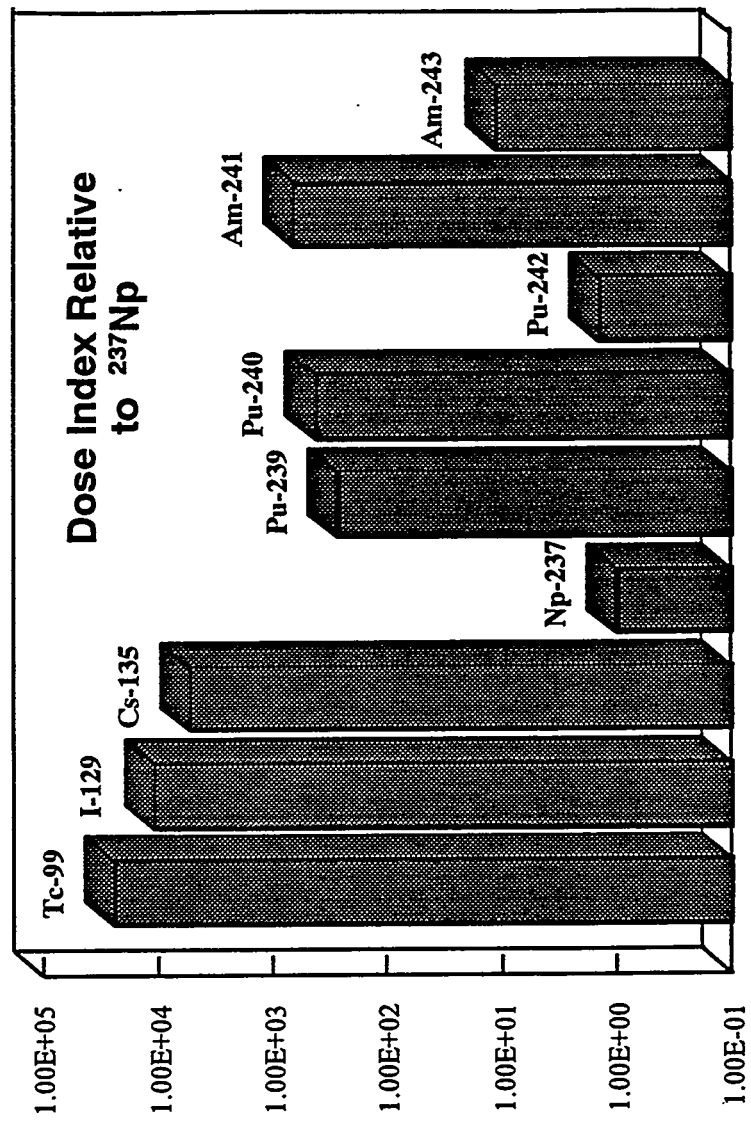

Dose Index = (Repository Inventory)(Fractional Dissolution Rate)(Dose Conversion Factor)

Target and Blanket Approaches

<u>Technical Approach</u>	<u>Aqueous (Reference)</u>	<u>Non Aqueous (Advanced)</u>
<u>Target</u>	Solid Tungsten/ Lead	Flowing Metal
<u>Multiplying Blanket</u>		
<u>Moderator Fluid Fuel</u>	D ₂ O Oxide Slurry	Graphite Molten Fluoride Salt
<u>Features</u>	Allows concept "existence proof"	Superior neutronics, economics
<u>Separations</u>	Demonstrated	Advanced

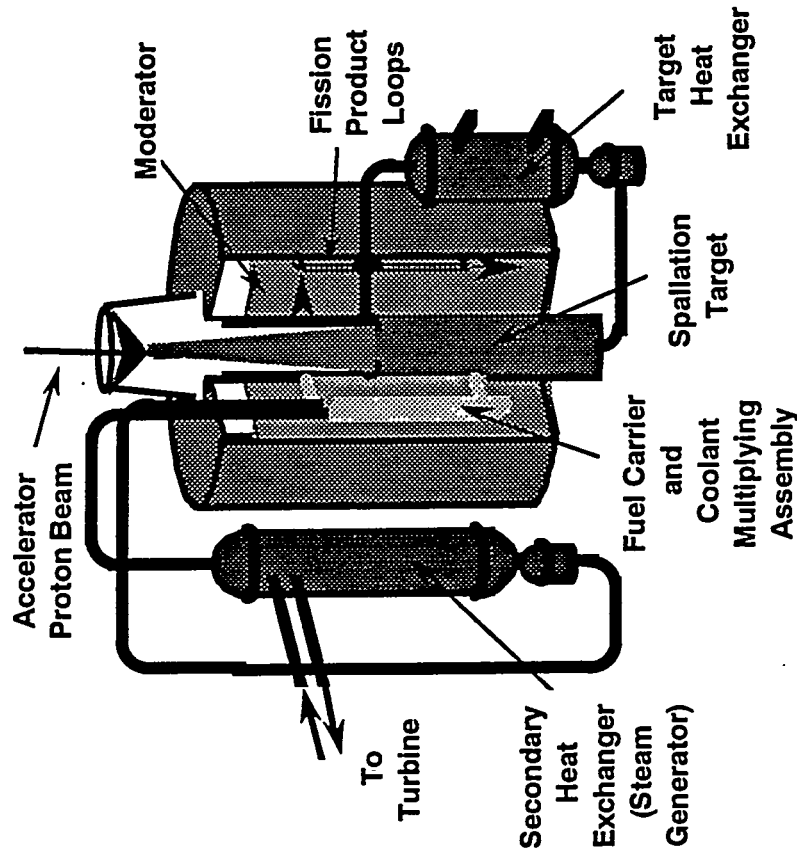

AQUEOUS-BASED ATW /ABC TARGET-BLANKET CONCEPT

Target-Blanket Configuration

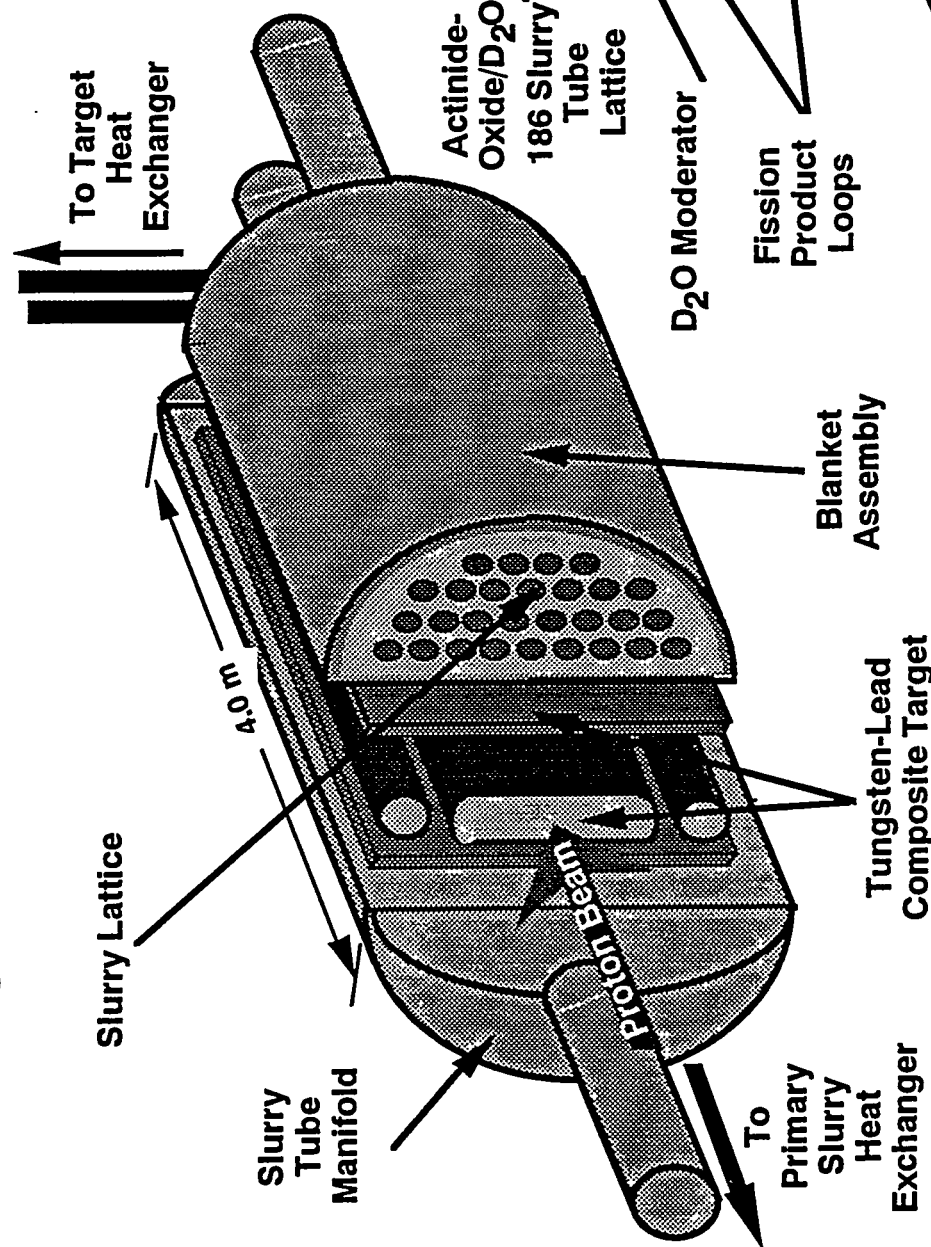

Blanket Actinide
Slurry Lattice and
FP Loops

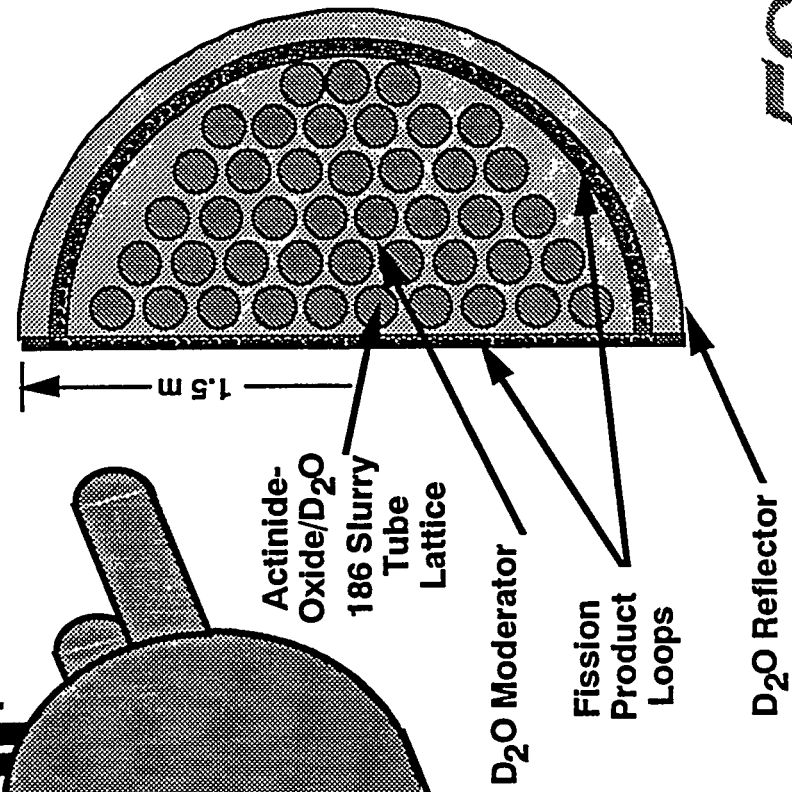

Example of an Aqueous Approach to ATW Separations

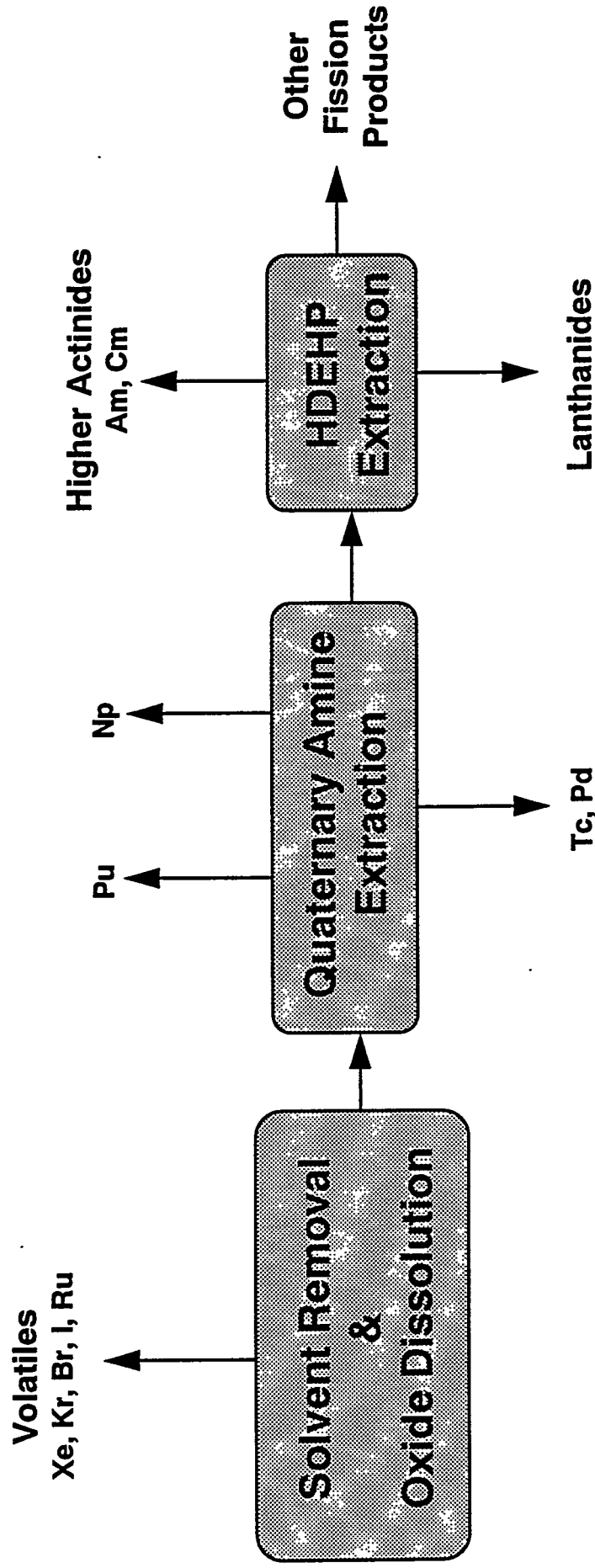

Ozonolysis Option for Tc/Ru Separation

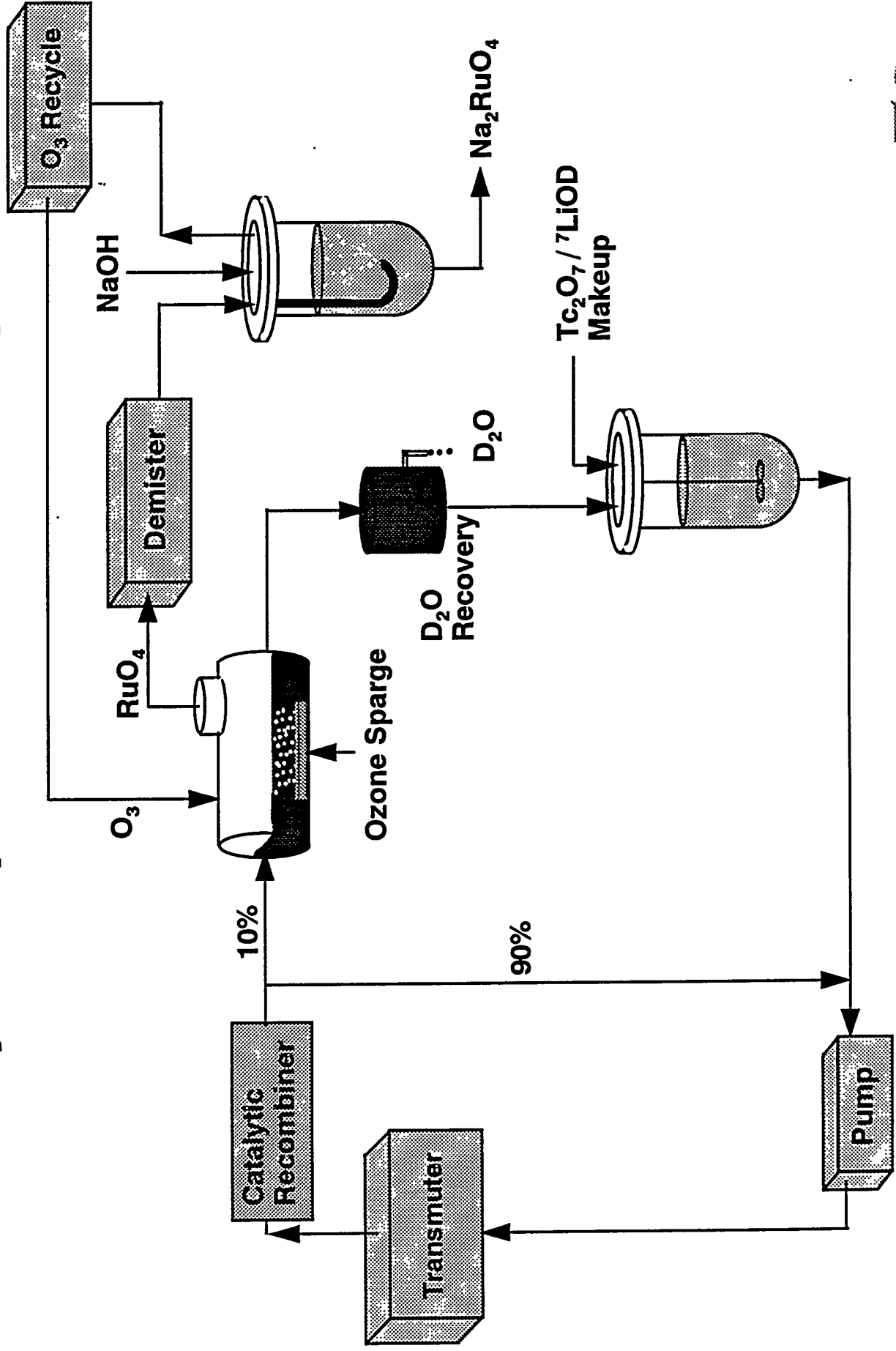

Schematic layout of the non-aqueous target/blanket assembly

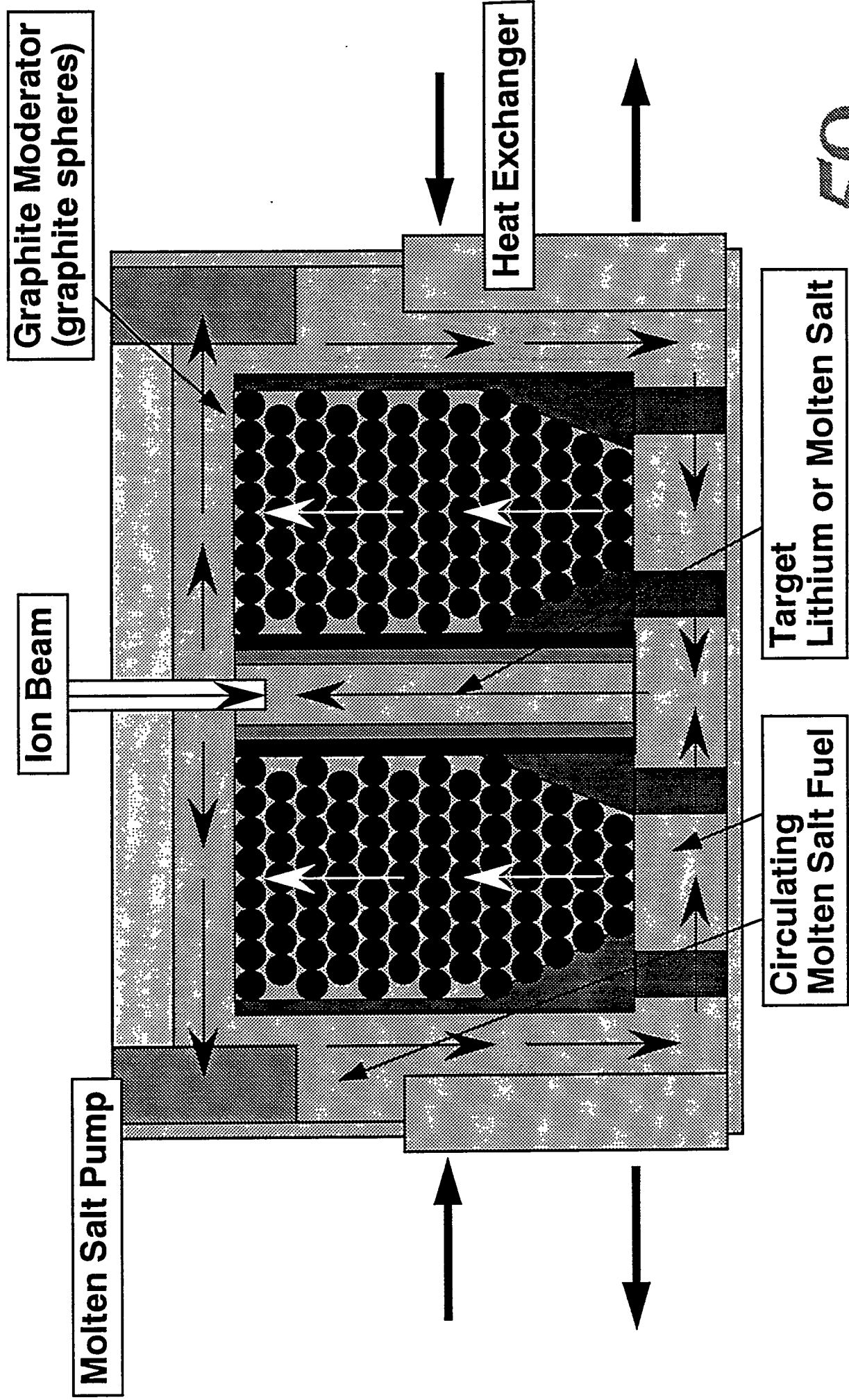

Accelerator Transmutation of Nuclear Waste: Towards the Elimination of Long-lived Radioactive Waste

Harry J. Dewey

Los Alamos National Laboratory

**13th Pyrochemical Workshop
Albuquerque, NM
October 18-21, 1993**

General Features ATW System

- Driven, sub critical system
- Intense thermal neutron fluxes
- High transmutation cross sections
- Minimal material inventories
- Continuous material feed
- Advanced separations

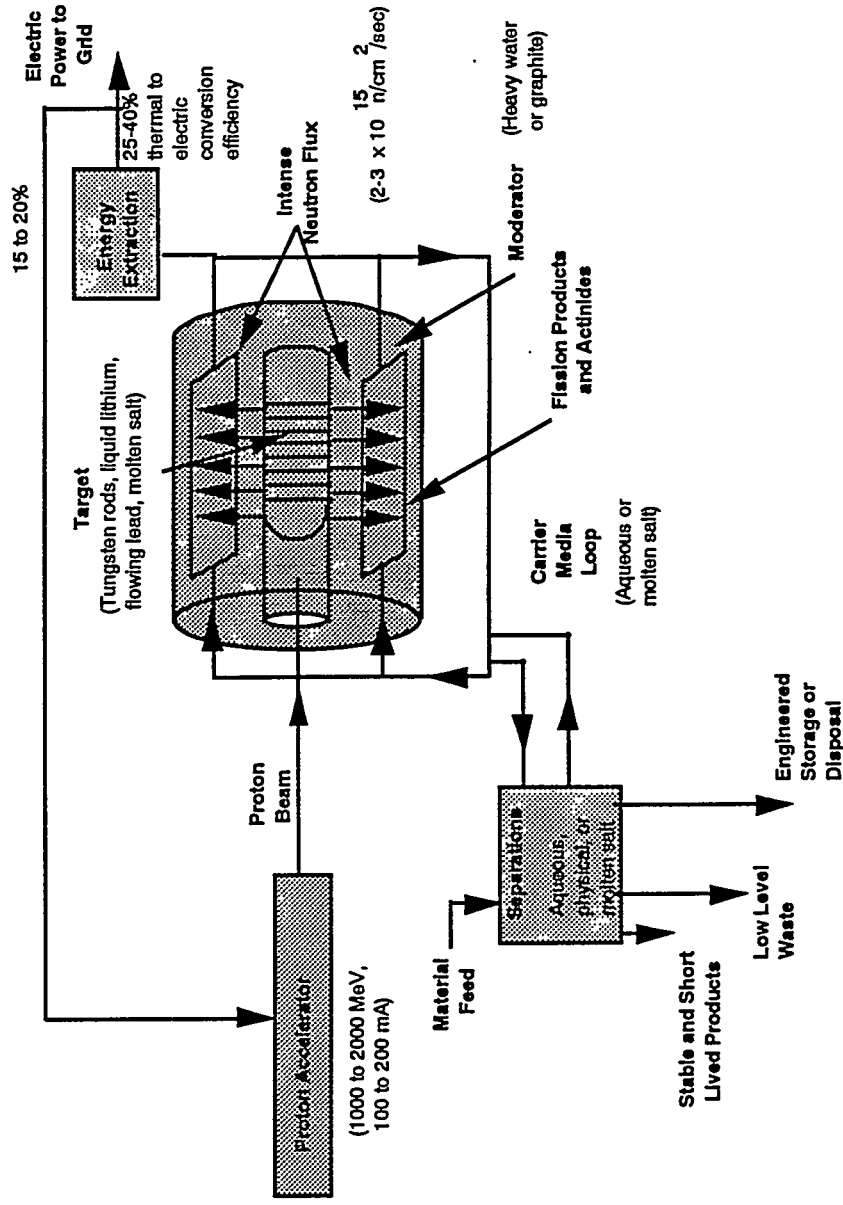

Long-Lived ($t > 30$ yr) Fission Products

Nuclide	Half-Life (years)	Isotopic Abundance	ATW Production Rate (g/kg fissioned)	Capture Cross Section (CANDU) (barns)
^{79}Se	6.50×10^4	11.24%	0.13	1.188
^{93}Zr	1.50×10^6	19.30%	13.75	2.123
^{99}Tc	2.13×10^5	100%	19.94	16.620
^{107}Pd	6.50×10^6	21.21%	15.02	6.760
^{126}Sn	1.00×10^5	40.41%	0.88	0.167
^{129}I	1.57×10^7	72.88%	5.27	15.370
^{135}Cs	2.30×10^6	7.30%	5.09	5.882

Radiation Dose from Contaminated Water from Proposed U.S. Repository is Dominated by Fission Products

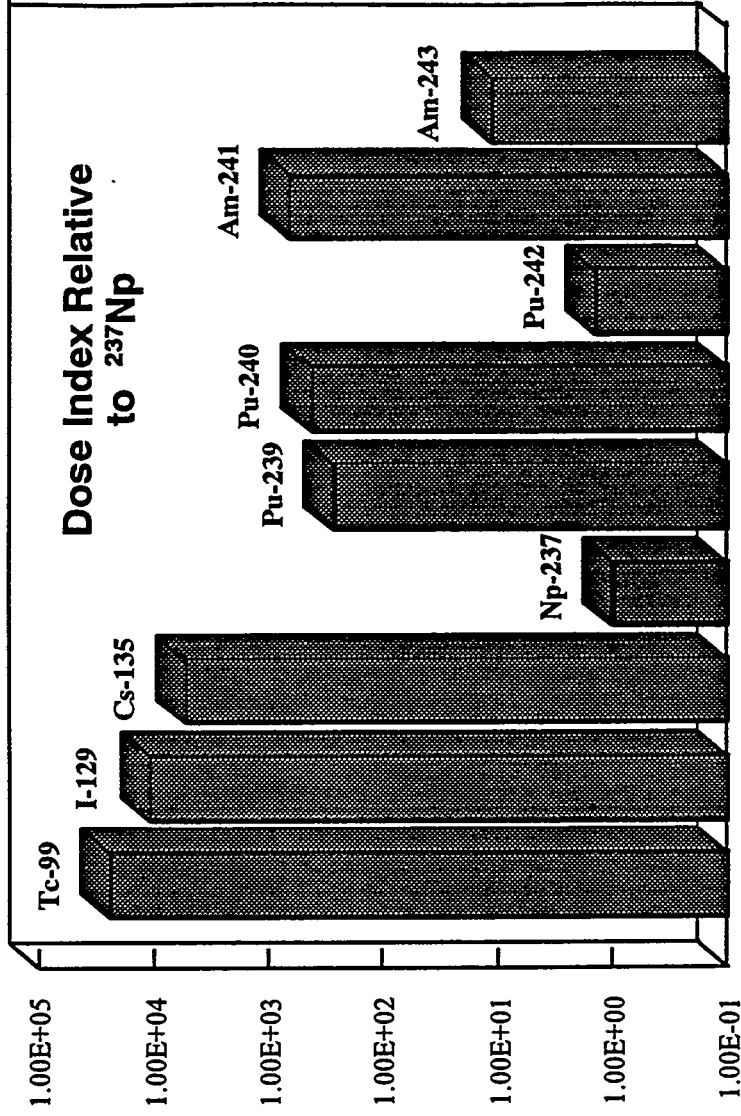

Species Half-life (yrs)

⁹⁹ Tc	213,000
¹²⁹ I	15,700,000
¹³⁵ Cs	2,300,000
²³⁷ Np	2,140,000
²³⁹ Pu	24,100
²⁴⁰ Pu	6,560
²⁴² Pu	375,000
²⁴¹ Am	433
²⁴³ Am	7370

Dose Index = (Repository Inventory)(Fractional Dissolution Rate)(Dose Conversion Factor)

50

Target and Blanket Approaches

<u>Technical Approach</u>	<u>Aqueous (Reference)</u>	<u>Non Aqueous (Advanced)</u>
<u>Target</u>	Solid Tungsten/ Lead	Flowing Metal
<u>Multiplying Blanket</u>		
<u>Moderator Fluid Fuel</u>	D ₂ O Oxide Slurry	Graphite Molten Fluoride Salt
<u>Features</u>	Allows concept "existence proof"	Superior neutronics, economics
<u>Separations</u>	Demonstrated	Advanced

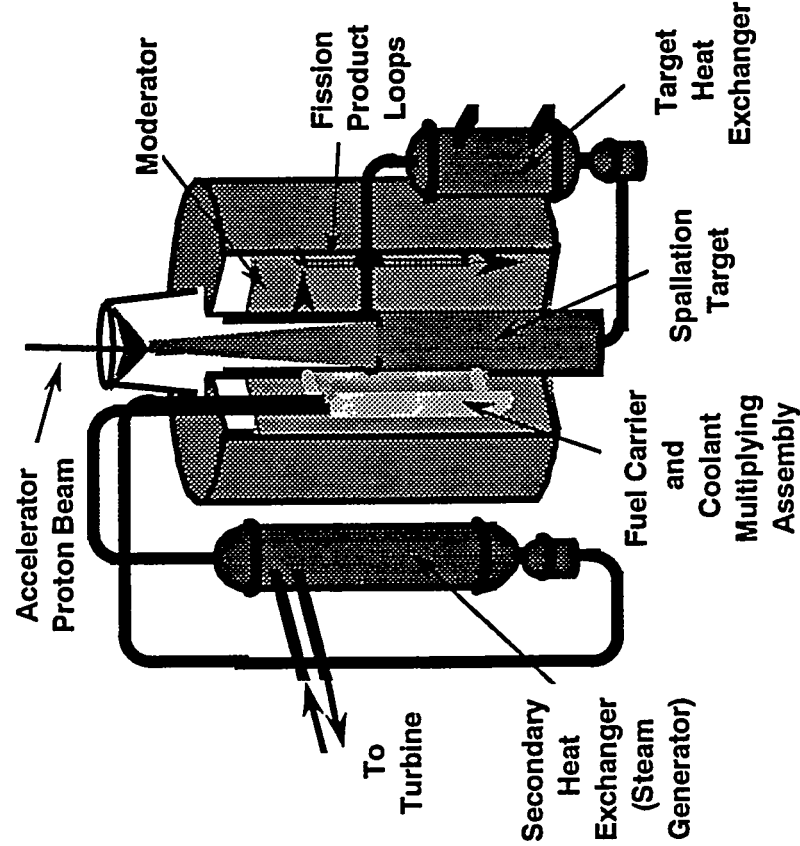

AQUEOUS-BASED ATW /ABC TARGET-BLANKET CONCEPT

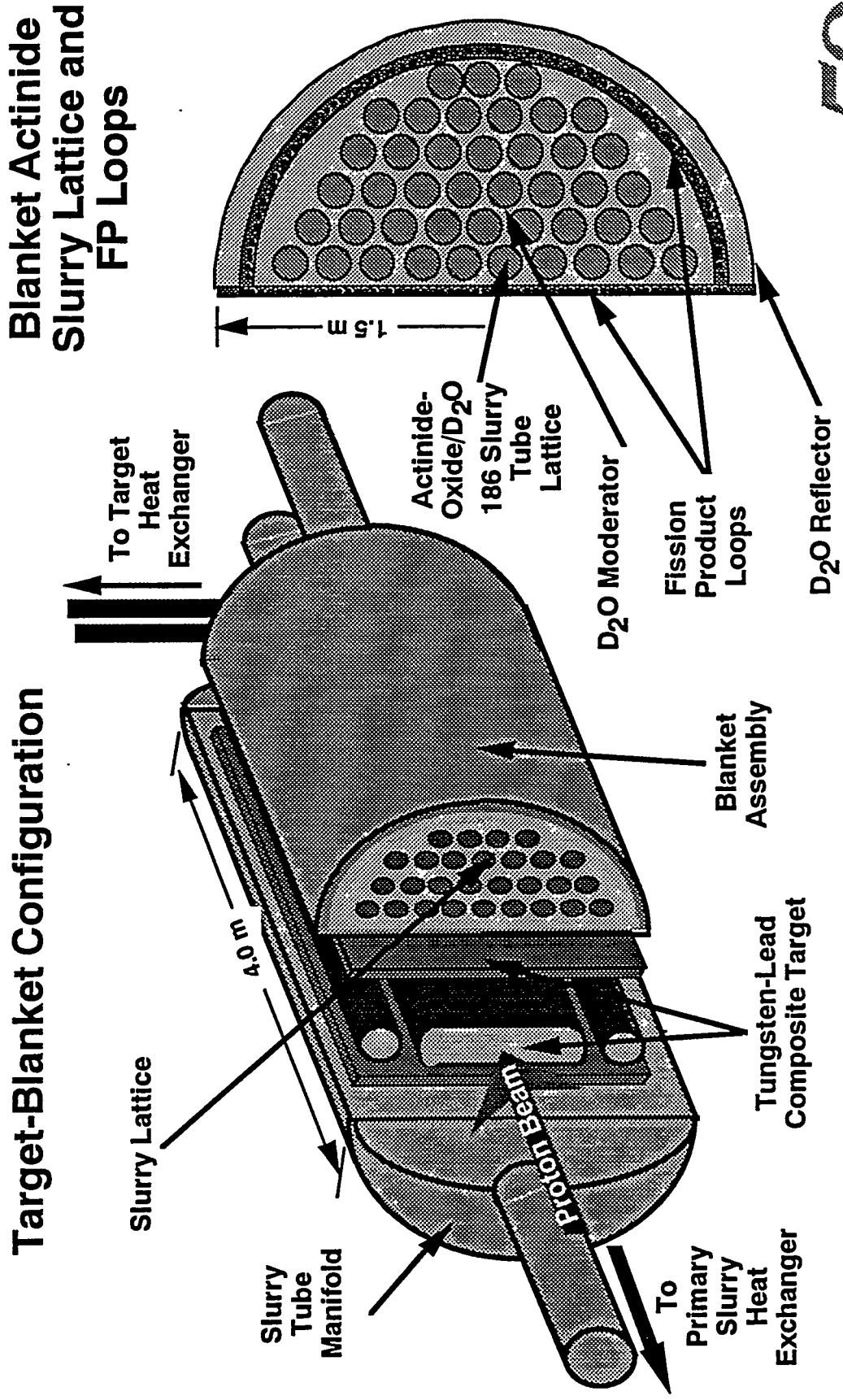

Example of an Aqueous Approach to ATW Separations

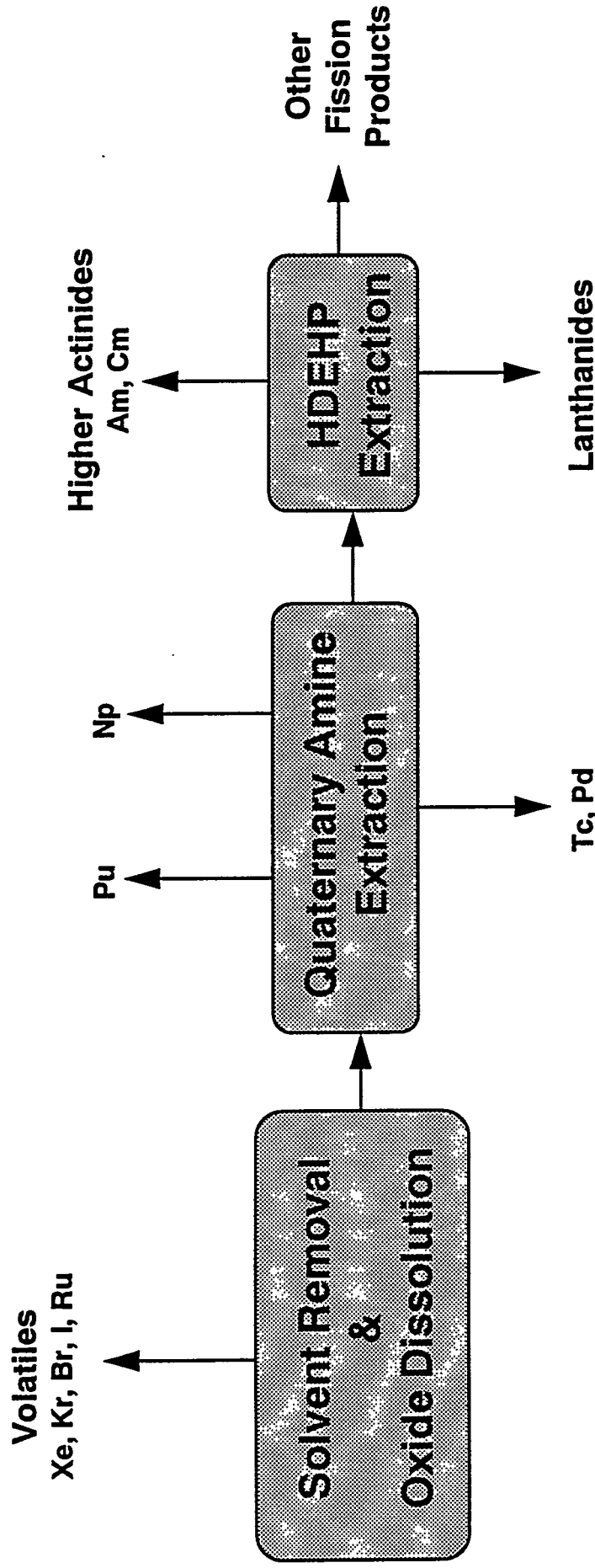

Ozonolysis Option for Tc/Ru Separation

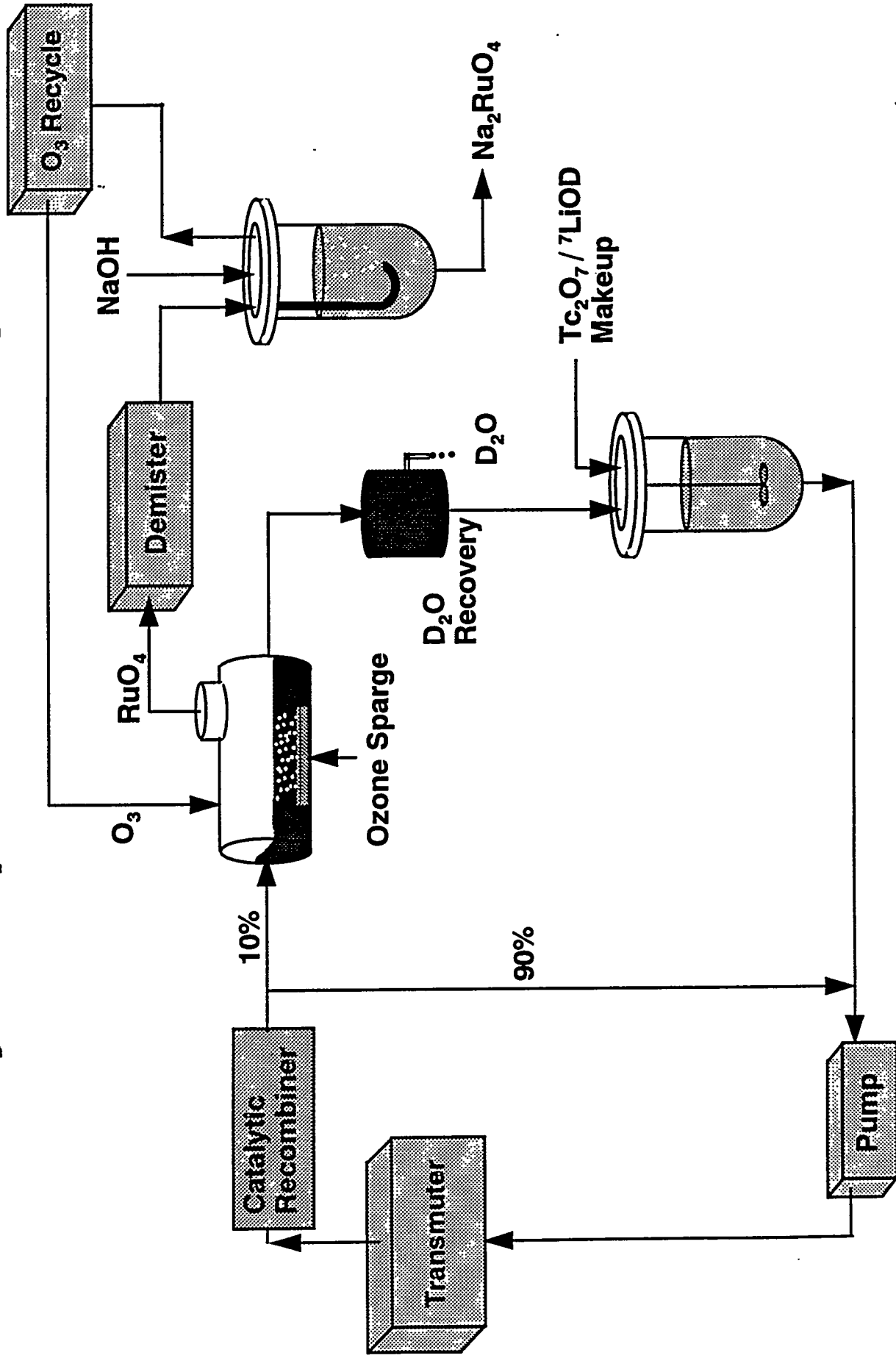

Schematic layout of the non-aqueous target/blanket assembly

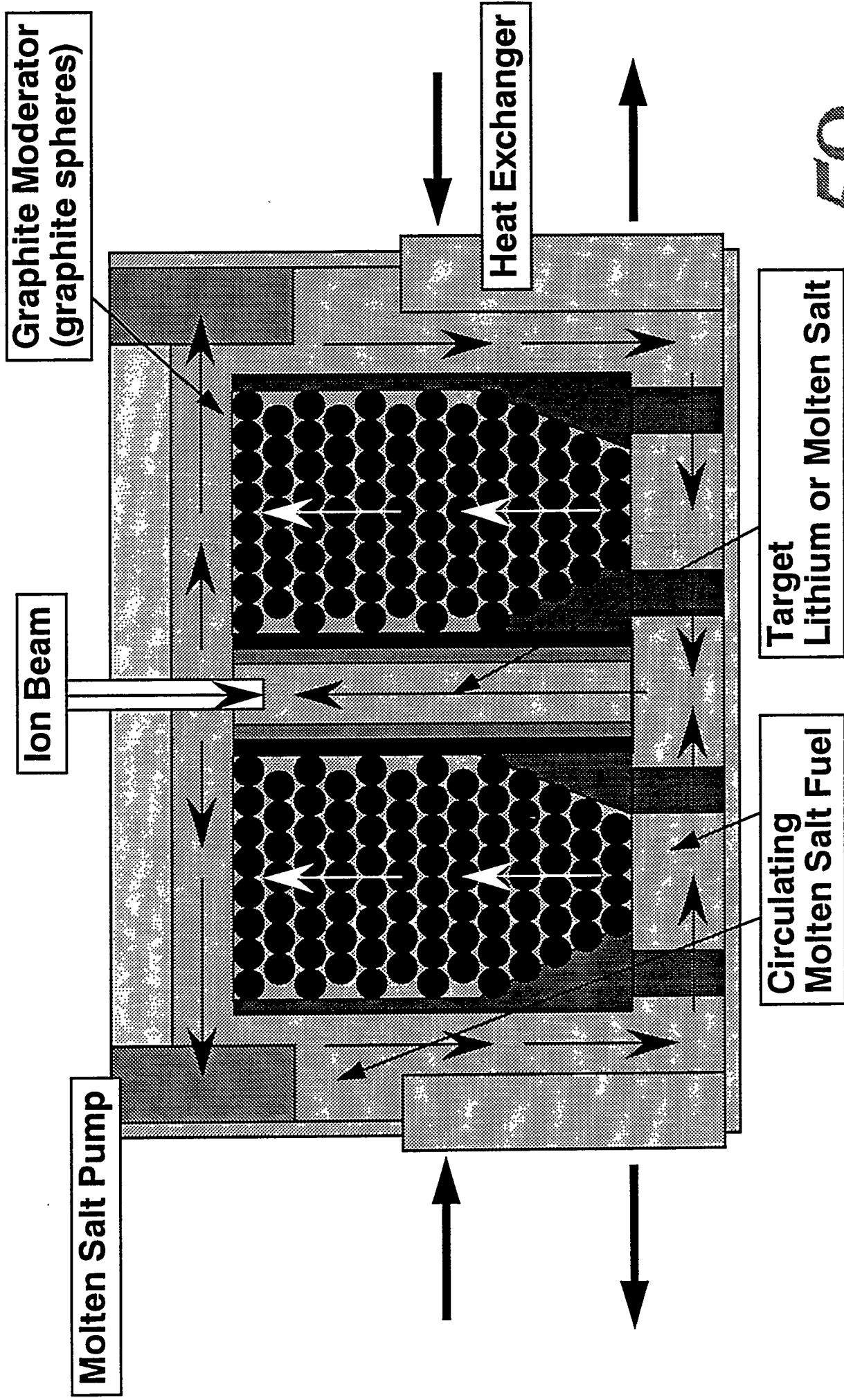

Accelerator Transmutation of Nuclear Waste: Towards the Elimination of Long-lived Radioactive Waste

Harry J. Dewey

Los Alamos National Laboratory

**13th Pyrochemical Workshop
Albuquerque, NM
October 18-21, 1993**

General Features ATW System

- Driven, sub critical system
- Intense thermal neutron fluxes
- High transmutation cross sections
- Minimal material inventories
- Continuous material feed
- Advanced separations

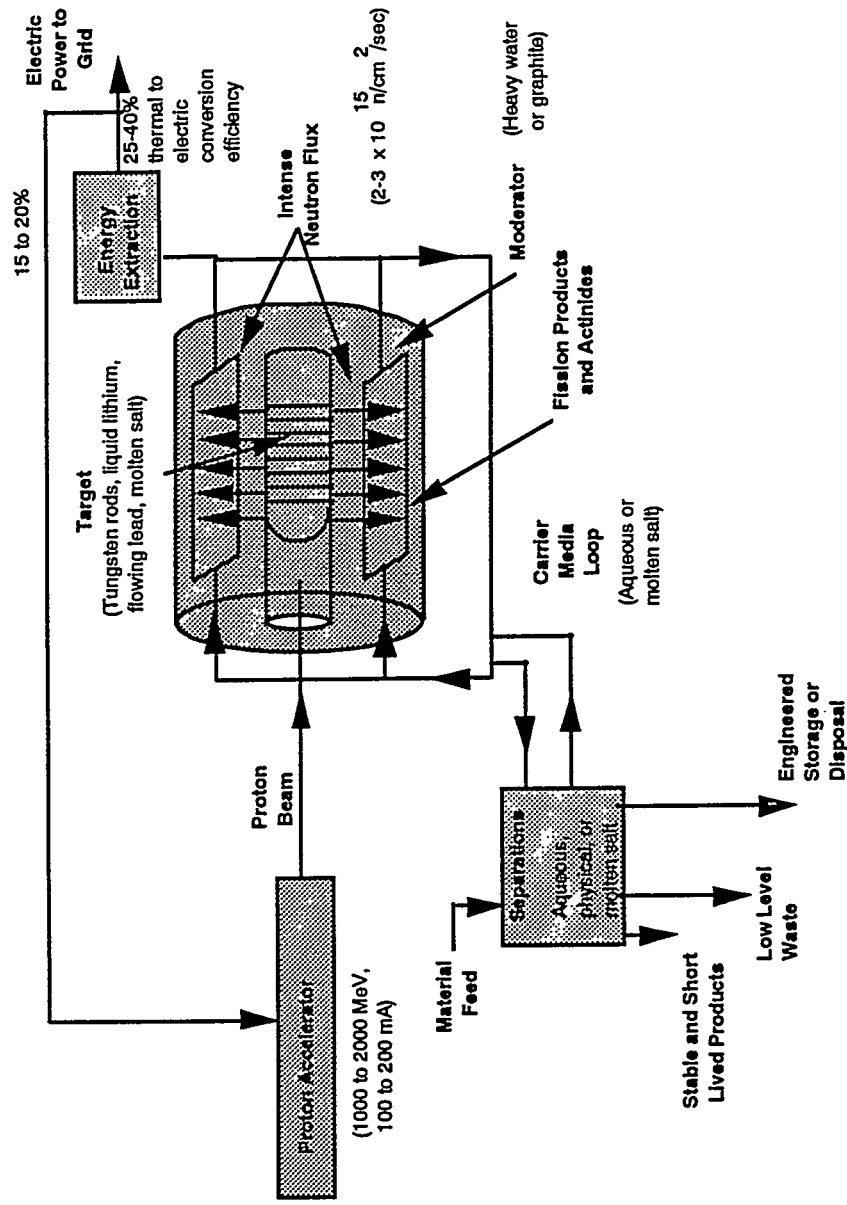

Long-Lived (>30 yr) Fission Products

Nuclide	Half-Life (years)	Isotopic Abundance	ATW Production Rate (g/kg fissioned)	Capture Cross Section (CANDU) (barns)
⁷⁹ Se	6.50x10 ⁴	11.24%	0.13	1.188
⁹³ Zr	1.50x10 ⁶	19.30%	13.75	2.123
⁹⁹ Tc	2.13x10 ⁵	100%	19.94	16.620
¹⁰⁷ Pd	6.50x10 ⁶	21.21%	15.02	6.760
¹²⁶ Sn	1.00x10 ⁵	40.41%	0.88	0.167
¹²⁹ I	1.57x10 ⁷	72.88%	5.27	15.370
¹³⁵ Cs	2.30x10 ⁶	7.30%	5.09	5.882

Radiation Dose from Contaminated Water from Proposed U.S. Repositories is Dominated by Fission Products

<u>Species</u>	<u>Halflife (yrs)</u>
⁹⁹ Tc	213,000
¹²⁹ I	15,700,000
¹³⁵ Cs	2,300,000
²³⁷ Np	2,140,000
²³⁹ Pu	24,100
²⁴⁰ Pu	6,560
²⁴² Pu	375,000
²⁴¹ Am	433
²⁴³ Am	7370

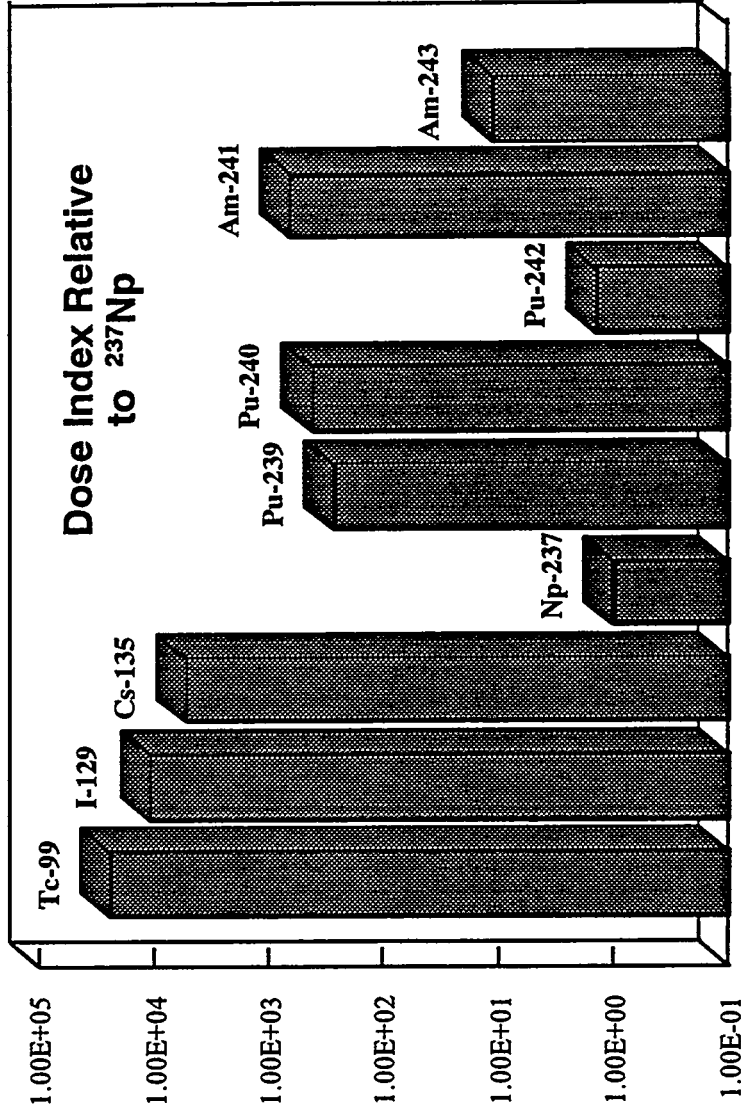

Dose Index = (Repository Inventory)(Fractional Dissolution Rate)(Dose Conversion Factor)

Target and Blanket Approaches

<u>Technical Approach</u>	<u>Aqueous (Reference)</u>	<u>Non Aqueous (Advanced)</u>
<u>Target</u>	Solid Tungsten/ Lead	Flowing Metal
<u>Multiplying Blanket</u>		
<u>Moderator Fluid Fuel</u>	D ₂ O Oxide Slurry	Graphite Molten Fluoride Salt
<u>Features</u>	Allows concept "existence proof"	Superior neutronics, economics
<u>Separations</u>	Demonstrated	Advanced

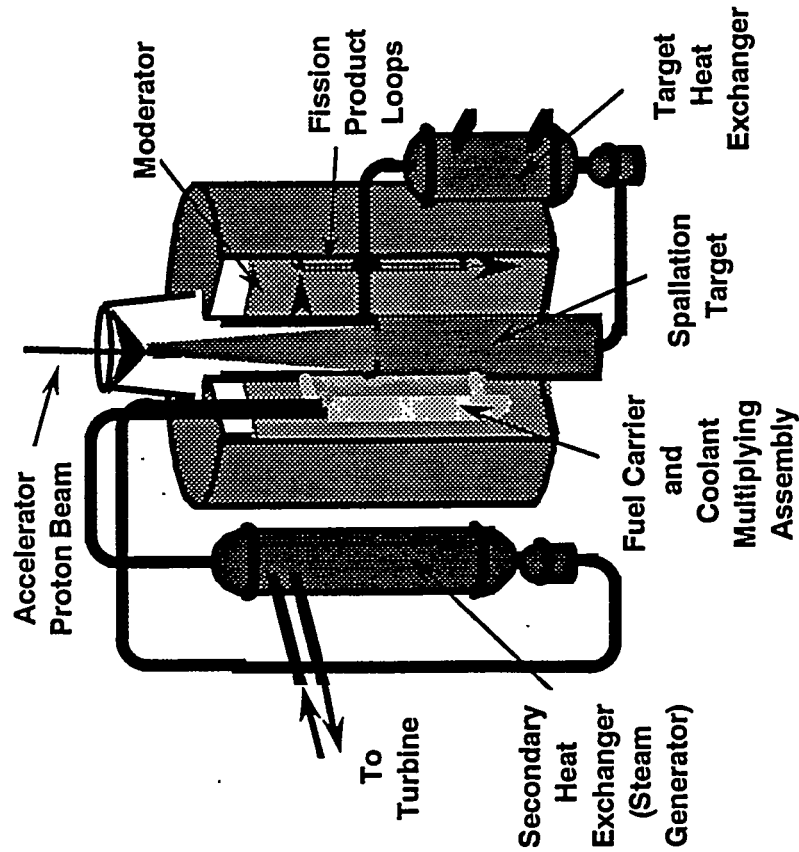

50

AQUEOUS-BASED ATW /ABC TARGET-BLANKET CONCEPT

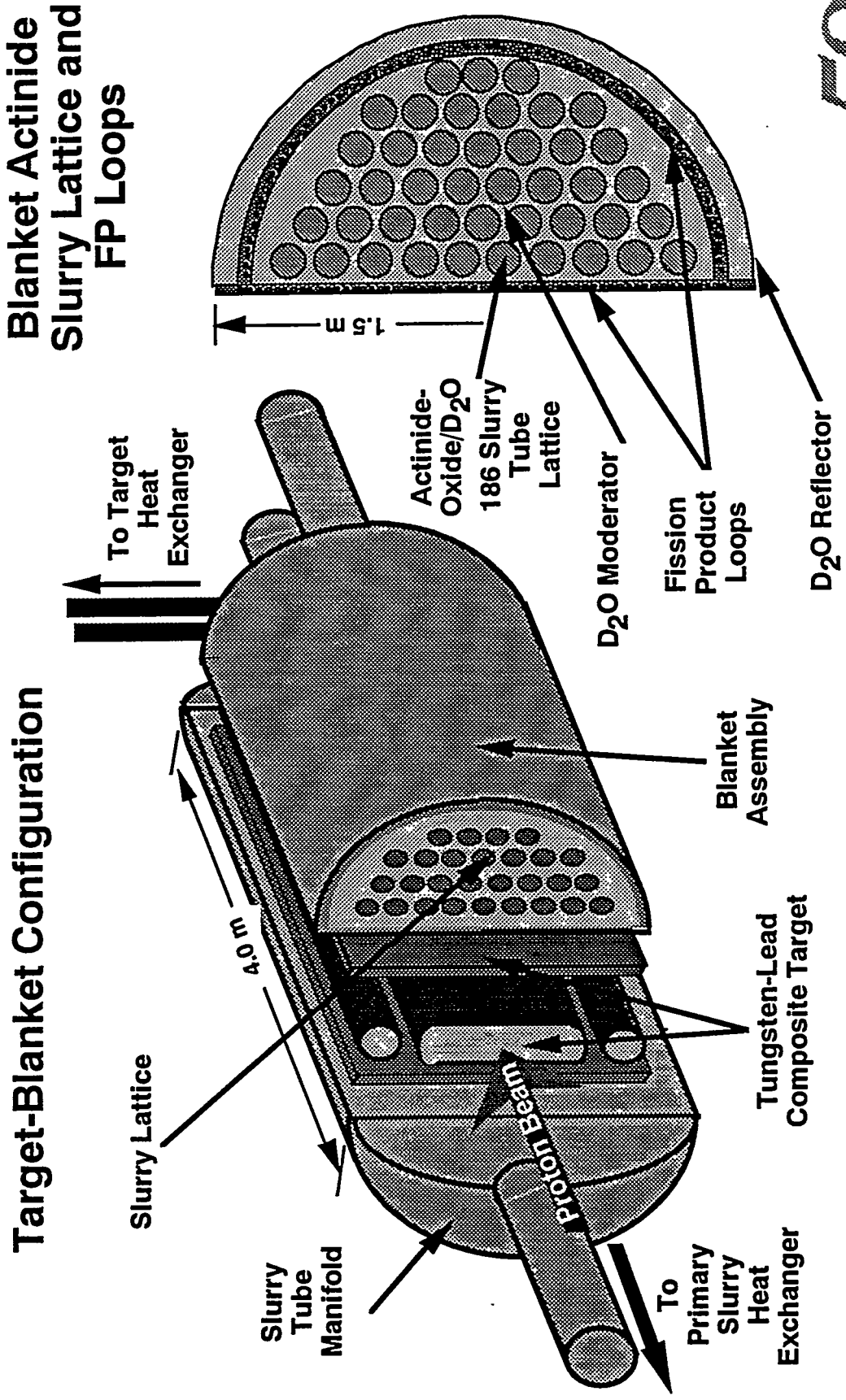

Example of an Aqueous Approach to ATW Separations

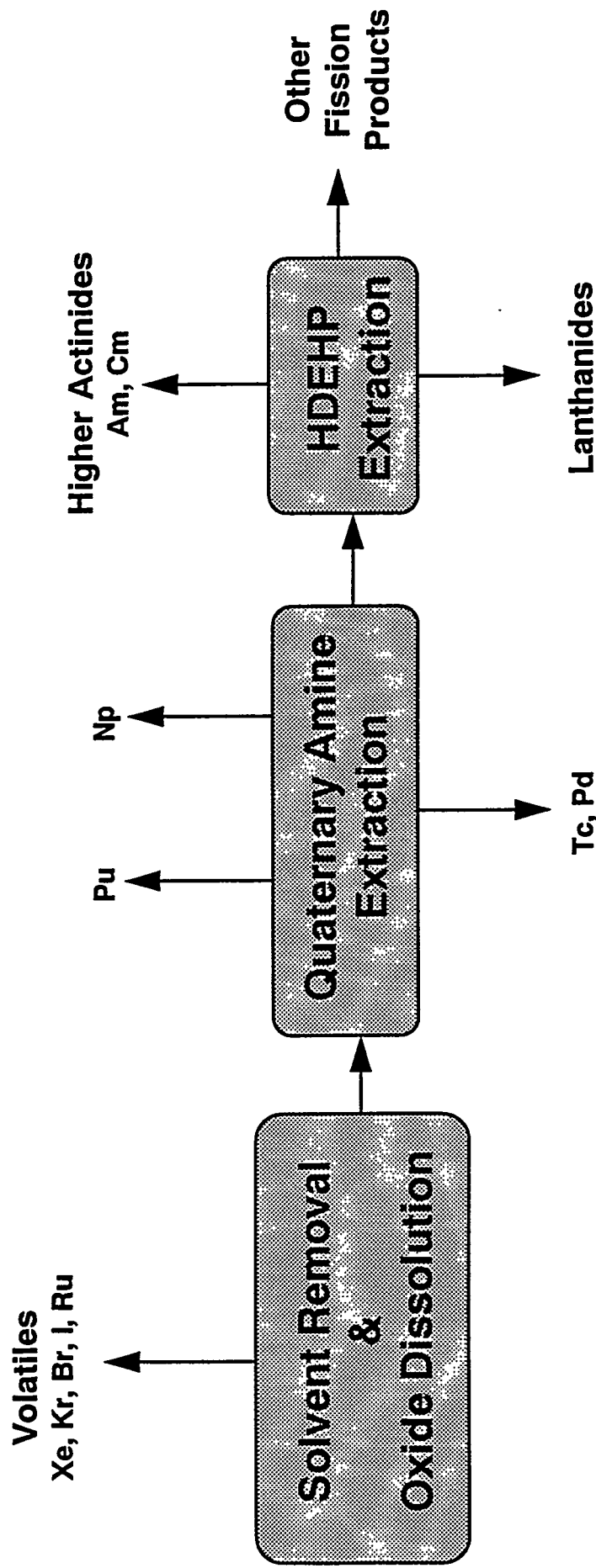

Ozonolysis Option for Tc/Ru Separation

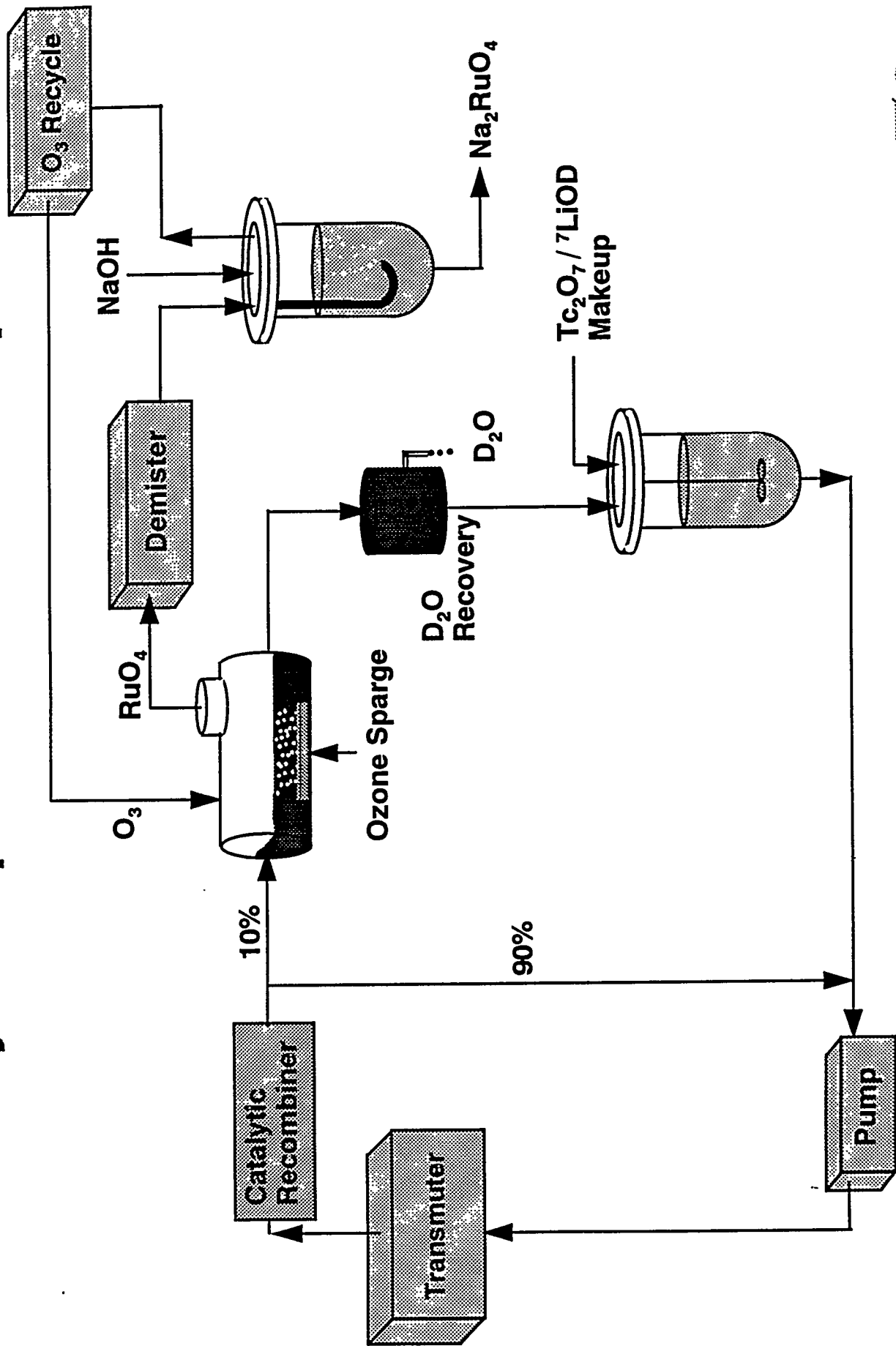

Schematic layout of the non-aqueous target/blanket assembly

