

Technical Progress Report

For the Period:

January 1, 1991 through December 31, 1991

Received OSTI
JUL 21 1992

Prepared For:

Rosebud SynCoal Partnership
Advanced Coal Conversion Process Demonstration
Colstrip, Montana

DOE Contract
DE-FC22-90PC89664

Prepared by:

Western Energy Company
Colstrip, Montana

February 1992

For submittal to:

United States Department of Energy
Pittsburgh Energy Technology Center

MASTER

LEGAL NOTICE

This report was prepared by Western Energy Company pursuant to a cooperative agreement partially funded by the U.S. Department of Energy and neither Western Energy Company nor any of its subcontractors nor the U.S. Department of Energy nor any person acting on behalf of either:

- (a) Makes any warranty or representation, express or implied with respect to the accuracy, completeness, or usefulness of the information contained in this report; or
- (b) Assumes any liabilities with respect to the use of, or for damages resulting from the use of, any information, apparatus, method or process disclosed in this report.

The process described herein is a fully patented process. In disclosing design and operating characteristics, neither Western Energy Company nor Rosebud Syncoal Partnership release any patent ownership rights.

References herein to any specific commercial product, process, or service by trade name, trademark, manufacturer, or otherwise, does not necessarily constitute or imply its endorsement, recommendation, or favoring by the U.S. Department of Energy. The views and opinion of authors expressed herein do not necessarily state or reflect those of the U.S. Department of Energy.

Table of Contents

	<u>Page</u>
1.0 Introduction and Purpose	1
2.0 Project Progress Summary	2
3.0 Process Description	3
4.0 Technical Progress	8
4.1 Facility and Equipment Design Engineering and Procurement	8
4.2 Topical Discussion	10
4.3 Site Construction	12
4.4 Permitting	15
4.5 Facility Startup and Testing	15
4.6 Production and Product Testing	15
5.0 Problem Areas and Lessons Learned	16
6.0 Future Work Areas	16

1.0 Introduction and Purpose

This report contains a description of technical progress made on the Advanced Coal Conversion Process Demonstration Project (ACCP). It serves as both the fourth quarter technical report and the annual technical report.

The project is a U.S. Department of Energy Clean Coal Technology Project. The cooperative agreement defining the project is between DOE and the Rosebud SynCoal Partnership (RSCP). The RSCP is a partnership between Western Energy Company (WECO), a subsidiary of Entech Inc., Montana Power Company's non-utility group, and NRG Inc., a subsidiary of Northern States Power.

This project will demonstrate an advanced thermal coal drying process coupled with physical cleaning techniques to upgrade high-moisture, low-rank coals to produce a high-quality, low-sulfur fuel. The coal will be processed through two vibrating fluidized bed reactors that will remove chemically bound water, carboxyl groups, and volatile sulfur compounds. After drying, the coal will be put through a deep-bed stratifier cleaning process to effect separation of the pyrite rich ash.

The process will enhance low-rank western coals, usually with a moisture content of 25-55%, sulfur content of 0.5-1.5%, and heating value of 5,500-9,000 Btu/lb by producing a stable, upgraded coal product with a moisture content as low as 1%, sulfur content as low as 0.3%, and heating value up to 12,000 Btu/lb.

The 45 ton/hr unit will be located adjacent to a unit train loadout facility at Western Energy Company's Rosebud coal mine near the town of Colstrip in southeastern Montana. The demonstration plant is sized at about one-tenth the projected throughput of a multiple processing train commercial facility. The demonstration drying and cooling equipment is currently commercial size.

2.0 Project Progress Summary

Design work is over 95% complete and construction is approximately 85% complete.

Previous to this reporting period, the piling was installed, and the two steel silos were completed. A total of about 26,415 linear feet of "H" pile has been driven along with about 17,900 square feet of sheet piling. A 1,000 ton raw coal storage silo and a 300 ton waste coal storage silo were erected.

The concrete storage silos are complete. Twin silos 70 feet in diameter and 120 feet tall were constructed. Each silo can hold up to 6,000 tons of product coal.

Work on the substructure is complete. The main building foundation, infeed hopper concrete, conveyor bent foundations, and underground piping are complete. A total of about 13,000 cubic yards of concrete were poured in construction activities including substructure and concrete silos.

The structural steel contractor completed work during the reporting period except for touchup painting and punchlist items. Approximately 450 tons of structural steel were erected.

The mechanical contractor continued work throughout the reporting period. The infeed equipment that prepares and stores raw coal for processing was completed. The majority of the process equipment was in-place at the beginning of the fourth quarter reporting period. During the fourth quarter, the process ductwork, process piping, and process gas circulating fans were completed. Insulation of process ductwork and piping and erection of conveyors and dust collectors continued throughout the fourth quarter.

The electrical contractor continued work throughout the fourth quarter. Electrical work in the infeed area, process building, and the electrical equipment room continued throughout the fourth quarter.

The administration building is complete. The 6,600 square foot building contains the facility control room, electrical equipment room, warehouse, office areas, and crew change areas.

The above ground fire protection contractor mobilized in late October 1991. Work began immediately in the fire pumphouse and on the three valvehouses. Work continued throughout the remainder of the fourth quarter.

Facility startup and initial production is currently projected to occur before the end of the first quarter of CY 1992. The project is currently about 11 weeks behind the partnership's accelerated schedule and about eight months ahead of the cooperative agreement schedule. Costs are being carefully monitored and the project is currently within its budget.

3.0 Process Description

In general the ACCP is a drying and conversion process using combustion products and superheated steam as fluidizing gas in vibrating fluidized beds. Two fluidized stages are used to heat and dry the coal and one water spray stage followed by one fluidized stage is used to cool the coal. Other systems servicing and assisting the coal conversion system are:

- Coal Cleaning
- Product Handling
- Raw Coal Handling
- Emission Control
- Heat Plant
- Heat Rejection
- Utility and Ancillary

The central processes are depicted in Figure 3.1, the Process Flow Schematic.

Coal Conversion

The coal conversion is performed in two parallel processing trains. Each consisting of two 5-foot wide by 30-foot long vibratory fluidized bed dryer/reactors in series, followed by a water spray section and a 5-foot wide by 25-foot long vibratory cooler reactor. Each processing train is fed 1,139 pounds per minute of 2 x 1/2 inch coal.

In the first-stage dryer/reactors, the coal is heated using recirculated combustion gases, removing primarily surface water from the coal. The coal exists the first-stage dryer/reactors, at a temperature slightly above that required to evaporate water. The coal exits the first stage dryer/reactor and gravity feeds the second-stage dryer/reactors, which further heats the coal using a recirculating gas stream, removing water trapped in the pore structure of the coal, and promoting decarboxylation. The water making up the superheated steam used in the second stage is actually produced from the coal itself. Particle shrinkage that liberates ash minerals and imparts a unique cleaning characteristic to the coal occurs in the second stage.

As the coal exists the second-stage dryer/reactors, it falls through vertical coolers where process water is sprayed onto the coal to reduce the temperature. The water vaporized during this operation is drawn back into the second-stage dryer/reactors. After water quenching, the coal enters the vibratory coolers where the coal is contracted by cool inert gas. The coal exits the cooler at less than 150 degree F and enters the coal cleaning system. The gas that exits the coolers is itself cooled by water sprays in contact coolers prior to returning to the coolers.

Figure 3.1

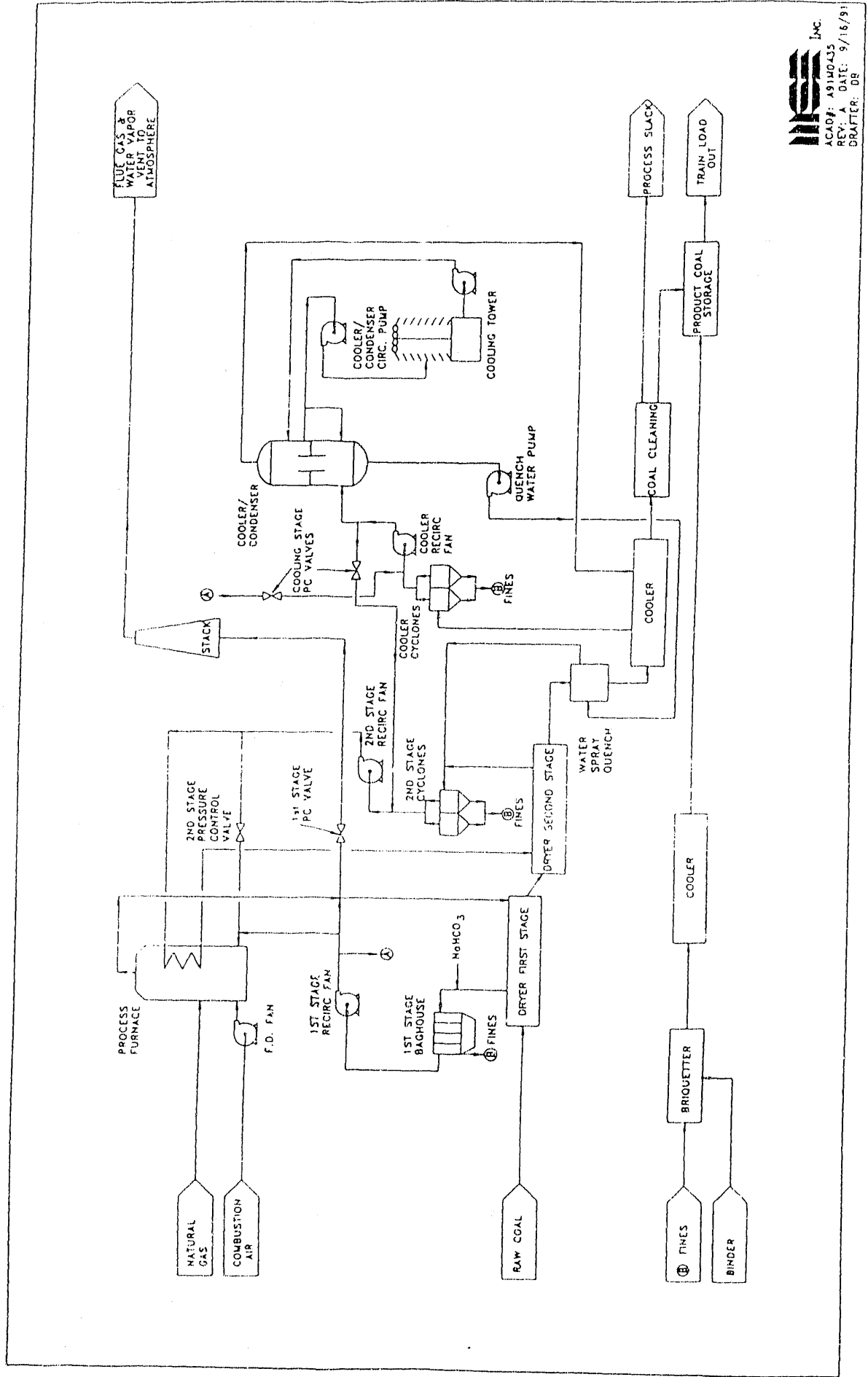



 INC.

 ACAD#: A9110435

 REV: A DATE: 9/16/91

 DRAFTER: DB

ROSEBUD SYNCOAL

 ADVANCED COAL CONVERSION PROCESS

 DEMONSTRATION PROJECT-PROCESS FLOW SCHEMATIC

Three interrelated recirculating gas streams are used in the coal conversion system; one each for the dryer/reactors and one for the coolers.

Gases enter the process from either the natural gas fired process furnace or from the coal itself. Combustion gases from the furnace are used in the first-stage dryer/reactors after exchanging some heat to the second-stage gas stream. The second-stage gas stream is composed mainly of superheated steam. It is heated by the furnace combustion gases in the heat exchanger. The cooler gas stream is made up of cooled furnace combustion gases that have been routed to the cooler loop.

A gas route is available from the cooler gas loop to the second stage dryer/reactor loop. Gas may also enter the first-stage dryer/reactor loop from the second-stage loop (termed make-gas) but not directly into the loop; rather the make-gas is used as an additional fuel source in the process furnace. The final gas route is the exhaust stream from the first-stage loop to atmosphere.

Gas exchange from one loop to another is governed by pressure control on each loop, and after startup, will be minimal from the first-stage loop to the cooler loop and minimal from the cooler loop to the second-stage loop.

Gas exchange from the second-stage loop to first-stage loop (through the process furnace) may be substantial because the water vapor and hydrocarbons driven from the coal in the second-stage dryer/reactors must leave the loop to maintain a steady state.

In each gas loop, upstream of the fans, are particulate removal devices to remove dust from the gas streams, protect the fans, and control emissions.

Coal Cleaning

The coal entering the cleaning system is screened into four size fractions: plus 1/2 inch, 1/2 by 1/4 inch, 1/4 inch by 6 mesh, and minus 6 mesh. These streams are fed in parallel to four deep-bed stratifiers (stoners), where a rough specific gravity separation is made using fluidizing air and a vibratory conveying action. The light streams from the stoners are sent to the product conveyor; the heavy streams from all but the minus 6 mesh stream are sent to fluidized bed separators. The heavy fraction of the minus 6 mesh stream goes directly to the waste conveyor. The fluidized bed separators, again using air and vibration to effect a gravity separation, each split the coal into light and heavy fractions. The light stream is considered product; the heavy or waste stream is sent to a 300 ton storage bin to await transport to an off site user or alternately back to a mined out pit disposal site. The dry, cool, and clean product from coal cleaning enters the product handling system.

Product Handling

Product handling, consists of the equipment necessary to convey the clean product coal to two 6,000 ton concrete silos and to allow train loading with the existing loadout system.

Raw Coal Handling

Raw coal from the existing stockpile is screened to provide 2 x 1/2 inch feed for the ACCP process. Coal rejected by the screening operation is conveyed back to the active stockpile. Properly sized coal is conveyed to a 1000 ton raw coal storage bin which feeds the process facility.

Emission Control

Sulfur dioxide emission control philosophy is based on injecting dry sorbents into the ductwork to minimize the release of sulfur dioxide to the atmosphere. Sorbents, such as trona or sodium bicarbonate, will be injected into the first stage dryer gas stream as it leaves the first stage dryers to maximize the potential for sulfur dioxide removal while minimizing reagent usage. The sorbents, having reacted with sulfur dioxide, will be removed from the gas streams in the particulate removal systems. A 60 percent reduction in sulfur dioxide emissions should be realized.

The coal cleaning area fugitive dust is controlled by placing hoods over the sources of fugitive dust conveying the dust laden air to fabric filter(s). The bag filters can remove 99.99 percent of the coal dust from the air before discharge. All fines will report to a briquetter and ultimately the product stream.

Heat Plant

The heat required to process the coal is provided by a natural gas fired process furnace. This system is sized to provide a heat release rate of 74 MM btu/hr. Process gas enters the furnace and is heated by radiation and convection from the burning fuel. Process make gas from coal conversion will be used as fuel in the furnace.

Heat Rejection

Most heat rejection from the ACCP will be accomplished by releasing water and flue gas to the atmosphere through an exhaust stack. The stack design will allow for vapor release at an elevation great enough that, when coupled with the vertical velocity resulting from a forced draft fan, dissipation of the gases will be maximized. Heat removed from the coal in the coolers will be rejected using an atmospheric induced-draft cooling tower.

Utility and Ancillary Systems

The coal fines that will be collected in the conversion, cleaning and material handling systems are gathered and conveyed to a surge bin. The coal fines will then be agglomerated and returned to the product stream.

Inert gas will be provided by cooling and drying combustion flue gases. This gas, primarily carbon dioxide and nitrogen, will be used principally for baghouse pulse and for makeup gas in the cooler loop.

The common facilities include a plant and instrument air system, a fire protection system, and a fuel gas distribution system.

The power distribution system includes a 15 KV service, a 15 KV/5 KV transformer, a 5 KV motor control center, two 5 KV/480 V transformers, a 480 V load distribution center, and a 480 V motor control center.

Control of the process is fully automated including dual control stations, dual programmable logic controllers, and a distributed plant control and data acquisition hardware.

4.0 Technical Progress

4.1 Facility and Equipment Design Engineering and Procurement

Previous to the fourth quarter reporting period, work was completed on general arrangement drawings, piping and instrumentation drawings, foundation drawings, structural steel drawings, electrical drawings, and plant control system programming.

During the fourth quarter reporting period, supply contracts were placed for the briquetter steel and the dust handling drag conveyors. Table 4.1 lists the equipment supply contracts. All major equipment procurement is now complete.

By the end of the reporting period, 99% of the plant equipment had arrived on the construction site.

Table 4.1 - ACCP Equipment Report

<u>Description</u>	<u>Contractor</u>	<u>Award Date</u>	<u>Delivery Complete</u>
Coal Dryers/Coolers	Carrier Vibrating Equip.	12/21/90	11/20/91
Belt Conveyors	Willis & Paul	04/01/91	01/15/92
Bucket Elevators	FMC Corporation	03/08/91	08/19/91
Coal Cleaning Equipment	Triple S Dynamics	01/25/91	07/24/91
Coal Screen	Hewitt Robins	12/21/90	06/20/91
Loading Spouts	Midwest International	05/13/91	07/24/91
Dust Agglomerator	Royal Oak	08/26/91	09/05/91
Briquetter Steel	Selway	10/21/91	12/15/91
Silo Mass Flow Gates	SEI Engineers	04/01/91	07/30/91
Vibrating Bin Dischargers	Carman Industries	03/14/91	07/30/91
Vibrating Feeder	Kinergy Corporation	03/22/91	07/19/91
Drag Conveyor	Dynomet	10/05/91	12/26/91
Process Gas Heater	G.C.Broach Company	01/25/91	07/30/91
Direct Contact Cooler	CMI-Schneible Co.	03/06/91	06/27/91
Particulate Removal Equip.	Air Cure Howden	03/06/91	08/19/91
Dust Collectors	Air Cure Environmental	06/07/91	11/26/91
Air Compressors/Dryers	Colorado Compressor Inc.	03/06/91	09/09/91
Fire Pumps-Diesel	Peerless Pump	05/30/91	10/24/91
Forced Draft Fan	Buffalo Forge Co.	12/21/90	11/01/91
Pumps	Dresser Industries Inc.	03/07/91	07/16/91
Electrical Equipment-4160	Toshiba International	03/14/91	08/19/91
Electrical Equipment-LDC	Powell	03/15/91	07/10/91
Electrical Equipment-MCC	Siemens	03/14/91	07/31/91
Main Transformer	ABB Power Company	01/04/91	08/12/91
Control Panels	Utility Control & Equip. Co.	03/08/91	08/20/91
Control Valves	Applied Control Equipment	05/24/91	09/03/91
Plant Control System	GE Supply Co.	02/08/91	04/01/91
Cooling Tower	JL Herman & Marley	02/01/91	06/24/91
Dampers	Effox Inc.	05/01/91	08/07/91
Dry Sorbent Injec. System	NaTech Resources Inc.	04/19/91	07/22/91
Expansion Joints	Flexonics	05/23/91	11/22/91

4.2 Topical Discussion

One Advantage of Upgraded Low Rank Coals

This project will demonstrate an advanced thermal coal drying process coupled with physical cleaning techniques to upgrade high-moisture, low-rank coals to produce a high-quality, low-sulfur fuel.

The process will enhance low-rank western coals with moisture contents ranging from 25-55%, sulfur contents between 0.5-1.5%, and heating values between 5,500-9,000 Btu/lb by producing a stable, upgraded coal product with moisture contents as low as 1%, sulfur contents as low as 0.3%, and heating values up to 12,000 Btu/lb.

This process and related processes are receiving increasing visibility and interest due to the enactment of new clean air regulations. Power production utilities have some very difficult and, in many situations, no-win decisions to make when complying with the clean air acts.

Most utilities are currently fairly well balanced between peak demand and generating potential. Economic growth reduces that margin; the utilities have, in the past, increased their generating potential to maintain an appropriate margin. In recent years, the utilities have reduced that margin due to capital cost concerns and permitting problems. Complying with the clean air act has compounded the effects of this reduced margin.

The methods for reducing sulfur emissions can generally be accomplished by either scrubbing or fuel switching.

Scrubbing is unappealing due to high capital costs, increased operating costs, and derating due to increased in-plant loads. Derating is a reduction of the full load output rating of a power plant and is an unattractive option for utilities that already have slim margins between demand and generating potential.

Fuel switching usually involves changing from the fuel that a power plant was designed to burn. In a typical case, a plant designed to burn 11,000 Btu/lb coal with 8% moisture and 3% sulfur would emit about 5.4 lb/MMBtu. In order to comply to the 1.2 lbs SO₂/MMBtu requirement the most attractive fuel switching coal would have 11,000 Btu/lb, less than 8% moisture, and less than 0.6% Sulfur. This is a very unlikely scenario because very few, if any, uncommitted coal reserves exist with these characteristics.

When fuel switching is made to a coal that does not have close to the same analysis as the plant design coal, numerous problems can be encountered including high capital costs to modify the plant to accept the new fuel and derating due to process limitations within the plant.

A typical western coal that might be used for switching in the above example might have 8,500 Btu/lb, 30% moisture, and less than 0.5% sulfur. When burning this western coal with the same burner firing rate, about 30% more coal is required, and proportionate increases in combustion air requirements and combustion gases production. It is very unlikely that this hypothetical power plant will be capable of moving this much additional mass through its equipment without modifications to numerous systems. The alternative to not performing these modifications is a derate of approximately 15%. A 500 MW rated power plant under this scenario would derate to 425 MW losing 75 MW of capacity.

One of the major advantages to the ACCP coal is that it, in effect, "discovers" a vast reserve of high quality low sulfur, coal that is attractive in the fuel switching scenario.

4.3 Site Construction

The piling contractor has completed work on the site; a total of about 26,415 liner feet of "H" pile has been driven along with about 17,900 square feet of sheet piling. Work on installing the piling began in February, 1991. The majority of the piling was installed by May 1991. The piling contractor returned to the site in July to install 17 additional piles.

The concrete storage silos are complete. Twin silos 70 feet in diameter and 120 feet tall were constructed. Each silo can hold up to 6,000 tons of product coal. Work began on the concrete storage silos in late April 1991 and was completed in October 1991.

Work on the substructure is complete. The main building foundation, infeed hopper concrete, conveyor bent foundations, and underground piping are complete. Work on the substructure began May 1, 1991 and was completed in October 1991. A total of about 13,000 cubic yards of concrete were poured in construction activities including substructure and concrete silos.

The two steel silos are complete. Work on the steel silos began in late June 1991 and was completed in September 1991. A 1,000 ton raw coal storage silo and a 300 ton waste coal storage silo were erected.

The structural steel contractor completed work during the reporting period except for touchup painting and punchlist items. Work began on the structural steel in August 1991. Approximately 450 tons of structural steel was erected.

The mechanical contractor continued work throughout the reporting period. Work by the mechanical contractor began in August 1991. The infeed equipment that prepares and stores raw coal for processing was substantially completed. The majority of the process equipment was in-place at the beginning of the fourth quarter reporting period. During the reporting period, the process duct-work, process piping, and process gas circulating fans were completed. Insulation of process ductwork and piping and erection of conveyors, and dust collectors continued throughout the reporting period.

The electrical contractor continued work throughout the reporting period. Work by the electrical contractor began in August 1991. Electrical work in the infeed area, process building, and the electrical equipment room continued throughout the reporting period.

The administration building is complete. Work on the administration building began in April 1991 and was completed in November 1991. The 6,600 square foot building contains the facility control room, electrical equipment room, warehouse, office areas, and crew change areas.

The above ground fire protection contractor mobilized in late October 1991. Work began immediately in the fire pumphouse and on the three valvehouses. Work continued throughout the remainder of the reporting period .

Facility startup and initial production is currently projected to occur before the end of the first quarter of CY 1992. The project is currently about 11 weeks behind the partnership's accelerated schedule and about eight months ahead of the cooperative agreement schedule. Costs are being carefully monitored and the project is currently within its budget.

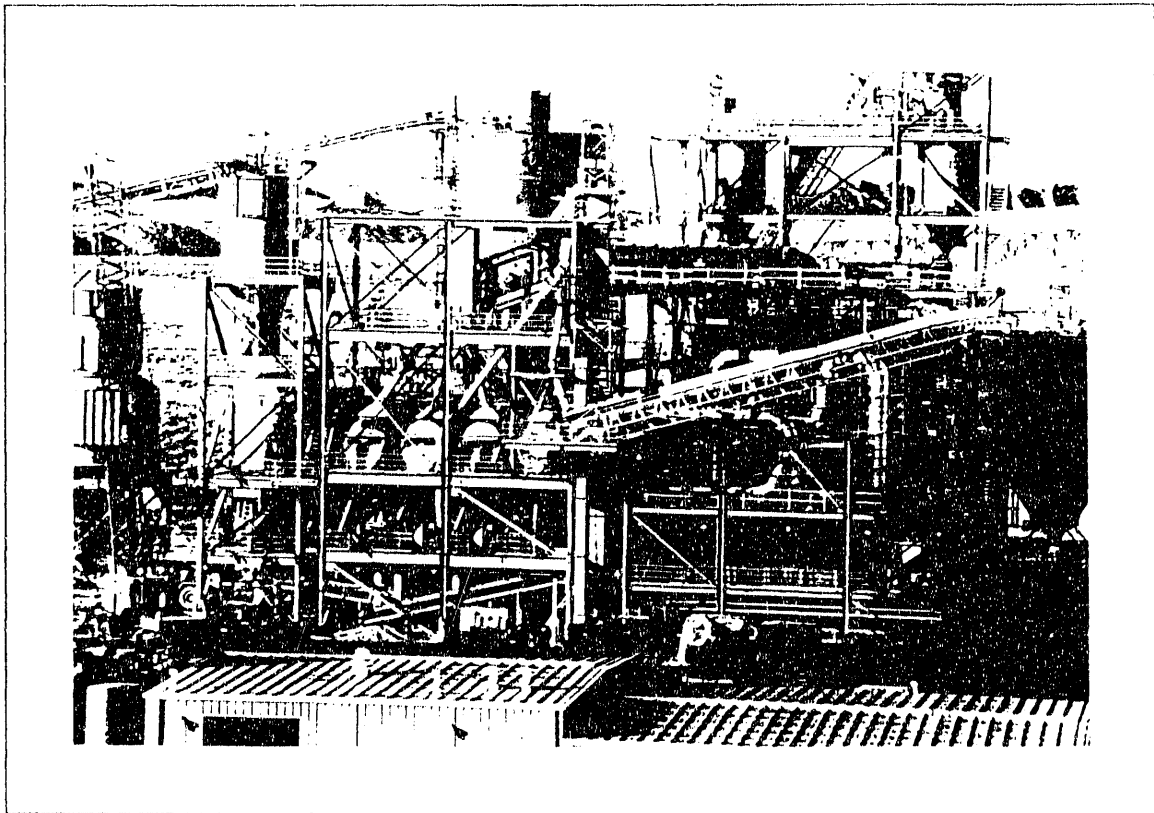
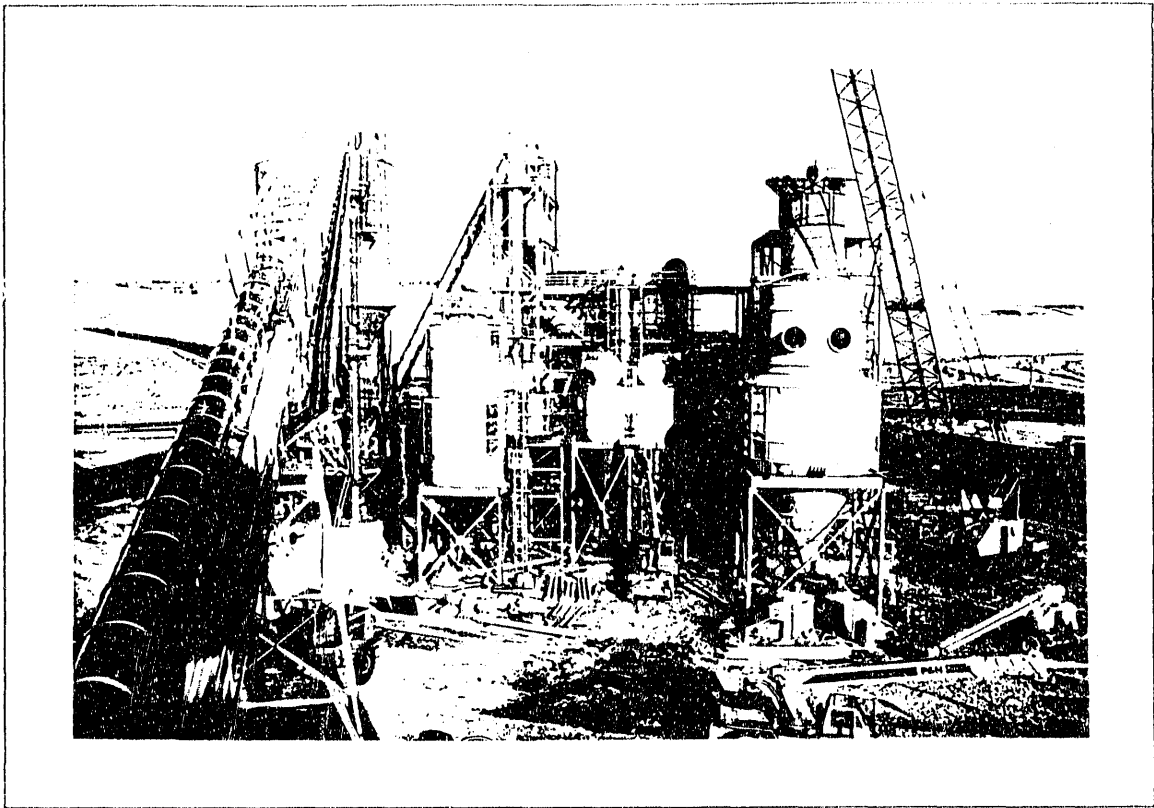

ACCP Construction Site
December 1991

4.4 Permitting

Approval of the request for an alteration to the existing air quality permit was received in July 1991.

A request for an alteration to the existing mine permit to allow deep-pit burial of the coal cleaning process slack is in processing at the Montana Department of State Lands. A request for further information was received in June 1991. Approval for this alteration was not received in the fourth quarter of 1991 as expected; and is now expected in the first quarter of 1992.

4.5 Facility Startup and Testing

Startup activities began in November 1991. About 60% of the equipment has been at least initially operated. Initial dried coal production is now projected for January 27, 1991. Initial startup will be performed by Stone and Webster Engineering.

As part of the initial production period, baseline testing of the process will be performed including compliance monitoring of the particulate removal systems. Preparation of a process test plan is underway. It will include performance tests on all process related equipment.

Initial startup discovered severe vibrations in the process fans. On the second stage drying gas fans, this was identified as a critical speed problem requiring a shaft rebuild.

Other significant problems identified were early release of pressure relief panels and inadequate tracking of 24" conveyor belts.

4.6 Production and Product Testing

Product production for 1992 is predicted to be 175,000 tons. The product will be sold to utilities and used in controlled test burns. Some initial test burn sales are already ensured.

NSP's Riverside plant will receive the first 5,000 ton test shipment for an initial test burn. Dairyland Power has committed to the next 5,000 ton test at their Alma station. Several utilities are working with RSCP to schedule tests. The process for test burns is being formulated and will include procedures for obtaining reportable data.

5.0 Problem Areas and Lessons Learned

During the reporting period, emphasis on expediting efforts shifted from vendors to site construction contractors. Completion of the process ductwork and conveyors were the most critical work areas for the mechanical contractor. Both power and I&C wiring for the infeed and processing building components were expedited in detail.

Construction activities are currently about 11 weeks behind the partnership's accelerated schedule. Excellent weather helped construction activities, but delays in delivery of material to the construction site and startup problems negated the good weather advantage.

Excessive vibration of the circulating gas fans was identified as a major problem. Troubleshooting efforts are underway.

6.0 Future Work Areas

Work continues on awarding facilitating and expediting contracts for equipment and construction.

Methods of obtaining test burn data from the product coal are being formulated.

END

**DATE
FILMED**

9 / 15 / 92

