

1 of 2

**REVISED CORRECTIVE ACTION PLAN FOR UNDERGROUND
STORAGE TANK 2331-U AT THE BUILDING 9201-1 SITE**

**OAK RIDGE Y-12 PLANT
OAK RIDGE, TENNESSEE
FACILITY ID # 0-010117**

**D.E. BOHRMAN
and
E.M. INGRAM**

DEC 07 1993

OSTI

SEPTEMBER 1993

**Environmental Management Department
Health, Safety, Environment, and Accountability Division**

Prepared by

**Science Applications International Corporation
Under Subcontract 18B-99928C
for the
Oak Ridge Y-12 Plant
Oak Ridge, Tennessee 37831**

Managed by

**Martin Marietta Energy Systems, Inc.
for the
U.S. Department of Energy
Under Contract No. DE-AC05-84OR21400**

MASTER

DISTRIBUTION OF THIS DOCUMENT IS UNLIMITED

ga

TABLE OF CONTENTS

| | Page |
|---|-------------|
| LIST OF FIGURES | vii |
| LIST OF TABLES | x |
| LIST OF ACRONYMS..... | xii |
| RESPONSIBLE PARTY & CONSULTANT INFORMATION..... | xiii |
| PROFESSIONAL GEOLOGIST AFFIRMATION..... | xiv |
| REGISTERED ENGINEER AFFIRMATION | xv |
| EXECUTIVE SUMMARY | ES-1 |
| | |
| 1.0 INTRODUCTION..... | 1-1 |
| 1.1 Purpose and Objectives | 1-1 |
| 1.2 Limitations..... | 1-2 |
| PART I - ENVIRONMENTAL ASSESSMENT | |
| | |
| 2.0 SITE LOCATION AND DESCRIPTION | 2-1 |
| | |
| 3.0 SITE HISTORY | 3-1 |
| 3.1 Introduction | 3-1 |
| 3.2 Release Discoveries and Equipment Testing..... | 3-1 |
| 3.3 Initial Site Characterization | 3-1 |
| 3.3.1 Initial Abatement/Tank Removal Activities | 3-1 |
| 3.3.2 Free Product Removal..... | 3-2 |
| 3.4 Soil Gas Survey..... | 3-6 |
| 3.5 Site Investigation..... | 3-6 |
| 3.5.1 Soil Boring Locations/Sampling | 3-6 |
| 3.5.2 Groundwater Monitoring Well Installation/Sampling | 3-7 |
| 3.6 Groundwater Quality Assessment Reports | 3-9 |
| 3.7 Quality Assurance/Quality Control..... | 3-10 |
| | |
| 4.0 GROUNDWATER INVESTIGATION | 4-1 |
| 4.1 Hydrological Setting..... | 4-1 |
| 4.1.1 Area Hydrology..... | 4-1 |
| 4.1.1.1 Area Groundwater System | 4-1 |
| 4.1.1.2 Area Surface Water System | 4-7 |
| 4.1.2 Site Hydrology..... | 4-7 |
| 4.1.2.1 Groundwater Characterization | 4-9 |
| 4.1.2.2 Slug Testing Analysis | 4-13 |
| 4.2 Groundwater Classification..... | 4-14 |
| 4.2.1 Groundwater Usage..... | 4-14 |
| 4.2.2 Groundwater Quality | 4-15 |
| 4.2.3 Applicable Remediation Levels | 4-16 |
| 4.3 Delineation of Groundwater Contamination | 4-16 |
| 4.3.1 Summary of Analytical Results | 4-16 |
| 4.3.2 Groundwater Contaminant Delineation | 4-16 |
| 4.3.2.1 Delineation Description | 4-16 |
| 4.3.2.2 Delineation Justification..... | 4-21 |
| | |
| 5.0 SOIL INVESTIGATION..... | 5-1 |
| 5.1 Geological Setting | 5-1 |
| 5.1.1 Area Geology..... | 5-4 |

TABLE OF CONTENTS (continued)

| | Page |
|--|-------------|
| 5.1.1.1 Bedrock..... | 5-4 |
| 5.1.1.2 Soil..... | 5-8 |
| 5.1.2 Site Geology..... | 5-9 |
| 5.1.2.1 Bedrock..... | 5-9 |
| 5.1.2.2 Soil..... | 5-11 |
| 5.2 Applicable Remediation Levels..... | 5-13 |
| 5.3 Delineation of Soil Contamination | 5-18 |
| 5.3.1 Summary of Analytical Results | 5-18 |
| 5.3.2 Soil Contaminant Delineation..... | 5-18 |
| 5.3.2.1 Delineation Description | 5-18 |
| 5.3.2.2 Extent of Soil Contamination at the Building 9201-1 Site | 5-24 |

PART II - CORRECTIVE ACTION PLAN

| | |
|--|------|
| 6.0 INTRODUCTION | 6-1 |
| 6.1 Purpose and Scope | 6-1 |
| 6.2 Limitations | 6-1 |
| 6.3 Background Information..... | 6-2 |
| 6.3.1 Characterization of Site Contamination..... | 6-2 |
| 6.3.2 Human Health Risk Assessment..... | 6-2 |
| 6.3.3 Environmental Exposure Assessment..... | 6-2 |
| 7.0 CORRECTIVE ACTIONS CONSIDERED..... | 7-1 |
| 7.1 Identification of Potential Corrective Action Options..... | 7-1 |
| 7.1.1 Corrective Action Objectives | 7-1 |
| 7.1.2 General Response Actions..... | 7-2 |
| 7.1.2.1 No Action/Institutional Actions | 7-2 |
| 7.1.2.2 Containment Actions | 7-2 |
| 7.1.2.3 Removal/Extraction Actions..... | 7-3 |
| 7.1.2.4 Collection/Control Actions | 7-3 |
| 7.1.2.5 Treatment Actions | 7-3 |
| 7.1.2.6 Storage/Disposal/Discharge Actions.. | 7-4 |
| 7.1.3 Initial Screening Criteria | 7-5 |
| 7.1.4 Initial Screening of Technologies and Process Options | 7-5 |
| 7.1.4.1 Soil Remediation..... | 7-5 |
| 7.1.4.2 Groundwater Remediation..... | 7-18 |
| 7.1.5 Development of Corrective Action Options..... | 7-34 |
| 7.1.5.1 Soil Remediation Corrective Action Options | 7-34 |
| 7.1.5.2 Groundwater Remediation Corrective Action Options | 7-37 |
| 7.2 Selection of Corrective Actions..... | 7-39 |
| 7.2.1 Evaluation Criteria..... | 7-39 |
| 7.2.1.1 Effectiveness | 7-39 |
| 7.2.1.2 Implementability | 7-39 |
| 7.2.1.3 Cost..... | 7-40 |
| 7.2.2 Evaluation of Corrective Actions | 7-40 |
| 7.2.2.1 Soil Remediation Evaluation..... | 7-40 |
| 7.2.2.2 Groundwater Remediation Evaluation..... | 7-47 |
| 7.2.3 Summary of Top Three Selected Corrective Action Options..... | 7-55 |
| 7.2.3.1 Corrective Action Options for Soil Remediation | 7-55 |

TABLE OF CONTENTS (continued)

| | Page |
|--|-------------|
| 7.2.3.2 Corrective Action Options for Groundwater Remediation | 7-62 |
| 8.0 CORRECTIVE ACTIONS CHOSEN | 8-1 |
| 8.1 Soil Corrective Action | 8-1 |
| 8.1.1 General Description of Soil Corrective Action | 8-1 |
| 8.1.2 Soil Remediation System Analysis | 8-1 |
| 8.1.2.1 Removal | 8-1 |
| 8.1.2.2 Soil Treatment | 8-8 |
| 8.1.2.3 Disposal of Soil | 8-12 |
| 8.2 Groundwater Corrective Action | 8-13 |
| 8.2.1 General Description of Groundwater Corrective Action | 8-13 |
| 8.2.2 Groundwater Remediation System Analysis | 8-13 |
| 8.2.2.1 Removal | 8-13 |
| 8.2.2.2 Groundwater Treatment and Disposal | 8-20 |
| 8.2.2.3 Discharge/Disposal of Groundwater | 8-22 |
| 9.0 PROPOSED IMPLEMENTATION SCHEDULE | 9-1 |
| 10.0 MONITORING AND REPORTING | 10-1 |
| 10.1 Baseline Report | 10-1 |
| 10.2 Monthly and Quarterly Reports | 10-1 |
| 10.3 Corrective Action Report | 10-2 |
| 11.0 HEALTH AND SAFETY PROCEDURES | 11-1 |
| 11.1 General Information | 11-1 |
| 11.2 Site-Specific Hazards, Required Protection, and Monitoring | 11-1 |
| 11.3 Safety Guidelines | 11-2 |
| 11.4 Required Training and Emergency Procedures | 11-4 |
| 12.0 REFERENCES | 12-1 |
| APPENDICES | |
| A Equipment Testing and Inspection Report | A-1 |
| B Site Investigation Soil Borehole Logs | B-1 |
| C Investigation Monitoring Well Borehole Logs and Construction Diagrams | C-1 |
| C.1 Free Product Recovery Well Borehole Log and Construction Diagram | C-2 |
| C.2 Site Investigation Monitoring Well Borehole Logs and Construction Diagrams | C-5 |
| D Laboratory Analytical Results for Initial Site Characterization Samples | D-1 |

TABLE OF CONTENTS (continued)

| | Page |
|--|-------------|
| D.1 Laboratory Analytical Results for Initial Site Characterization Soil Samples | D-2 |
| D.2 Laboratory Analytical Results for Initial Site Characterization Surface Water Outfall Samples..... | D-10 |
| E Soil Gas Survey | E-1 |
| F Laboratory Analytical Results for Site Investigation Samples..... | F-1 |
| F.1 Laboratory Analytical Results for Site Investigation Soil Samples | F-2 |
| F.2 Laboratory Analytical Results for Site Investigation Groundwater Samples | F-9 |
| G Laboratory Analytical Results for Groundwater Quality Assessment Samples | G-1 |
| G.1 Laboratory Analytical Results for 1990 Groundwater Quality Assessment Samples | G-2 |
| G.2 Laboratory Analytical Results for 1991 Groundwater Quality Assessment Samples | G-7 |
| H Slug Test Analysis Calculations..... | H-1 |

LIST OF FIGURES

| Figure | Title | Page |
|---------------|--|-------------|
| 2-1 | Location of the Building 9201-1 Site..... | 2-2 |
| 2-2 | Building 9201-1 Site Map | 2-3 |
| 2-3 | Building 9201-1 Site Underground Storage Tank and Underground Service Utilities Map | 2-4 |
| 2-4 | Y-12 Plant Topographic Contour Map | 2-5 |
| 2-5 | Building 9201-1 Site Topographic Contour Map | 2-6 |
| 3-1 | Initial Site Characterization Soil Sample and Surface Water Sampling Locations..... | 3-3 |
| 3-2 | Building 9201-1 Site Free Product Removal Recovery/Monitoring Well Location..... | 3-4 |
| 3-3 | Building 9201-1 Site Investigation Soil Boring and Monitor Well Locations | 3-8 |
| 4-1 | Hydrogeologic Regimes at the Y-12 Plant..... | 4-2 |
| 4-2 | Conceptual Groundwater Flow Patterns in the Vicinity of the Oak Ridge Y-12 Plant | 4-5 |
| 4-3 | Water Table Elevations at the Y-12 Plant (1984-1989)..... | 4-6 |
| 4-4 | Tetrahedral Continuum Between Four Major Types of Aquifers and Dominant Pore Geometry in Each | 4-8 |
| 4-5 | Building 9201-1 Site Groundwater Potentiometric Contour Map for May/June..... | 4-10 |
| 4-6 | Building 9201-1 Site Groundwater Cross-Section, Borehole, and Monitoring Well Locations | 4-20 |
| 4-7 | Horizontal Extent of Groundwater Benzene and TPH Contamination at the Building 9201-1 Site | 4-22 |
| 4-8 | Building 9201-1 Site Vertical Extent of Groundwater Contamination Along Cross-Section A-A'..... | 4-23 |
| 4-9 | Building 9201-1 Site Vertical Extent of Groundwater Contamination Along Cross-Section B-B'..... | 4-24 |
| 4-10 | Building 9201-1 Site Vertical Extent of Groundwater Contamination Along Cross-Section C-C'..... | 4-25 |
| 5-1 | Physiographic Map of Tennessee and Bedrock Geology at the Oak Ridge Reservation | 5-2 |

LIST OF FIGURES (continued)

| Figure | Title | Page |
|---------------|---|-------------|
| 5-2 | Bedrock Geology and Surface Drainage at the Oak Ridge Y-12 Plant and Vicinity..... | 5-3 |
| 5-3 | Geologic Cross-Section of the White Oak Mountain Thrust Sheet in the Vicinity of the Oak Ridge Y-12 Plant..... | 5-5 |
| 5-4 | Stratigraphic Column of Bedrock Units in the Vicinity of the Oak Ridge Y-12 Plant | 5-7 |
| 5-5 | Idealized Cross-Section of Soil and Unconsolidated Material in the Bear Creek Valley, Oak Ridge Y-12 Plant..... | 5-10 |
| 5-6 | Building 9201-1 Site Soil Cross-Section, Borehole, Grab Sample, and Monitoring Well Locations | 5-12 |
| 5-7 | Building 9201-1 Site Geologic Cross-Section A-A'..... | 5-14 |
| 5-8 | Building 9201-1 Site Geologic Cross-Section B-B'..... | 5-15 |
| 5-9 | Building 9201-1 Site Geologic Cross-Section C-C'..... | 5-16 |
| 5-10 | Building 9201-1 Site Composite Soil Contamination Map | 5-20 |
| 5-11 | Building 9201-1 Site Vertical Extent of Soil Contamination Along Cross-Section A-A'..... | 5-22 |
| 5-12 | Building 9201-1 Site Vertical Extent of Soil Contamination Along Cross-Section B-B'..... | 5-23 |
| 8-1 | Soil Treatment Process Flow..... | 8-2 |
| 8-2 | Building 9201-1 Site Horizontal Zone of Influence Map | 8-4 |
| 8-3 | Building 9201-1 Site Vertical Zone of Influence Map | 8-6 |
| 8-4 | Groundwater Treatment Process Flow..... | 8-14 |
| 8-5 | Groundwater Treatment Facility Location | 8-15 |
| 8-6 | Building 9201-1 Site Zone of Groundwater Contamination of Benzene and TPH | 8-17 |
| 8-7 | Potentiometric Surface at the Building 9201-1 Site..... | 8-18 |
| 8-8 | Building 9201-1 Site Vertical Extent of Groundwater Contamination and 45-Day Drawdown Along Cross-Section D-D'..... | 8-19 |
| E-1 | Building 9201-1 Site Sampling Grid for Soil Gas Survey..... | E-5 |
| E-2 | Results from the Soil Gas Survey at the Building 9201-1 Site..... | E-9 |

LIST OF FIGURES (continued)

| Figure | Title | Page |
|---------------|---|-------------|
| E-3 | Building 9201-1 Site Benzene Concentration Contours from Soil Gas Survey..... | E-11 |
| E-4 | Building 9201-1 Site Toluene Concentration Contours from Soil Gas Survey..... | E-12 |
| E-5 | Building 9201-1 Site HNu Concentration Contours from Soil Gas Survey..... | E-13 |
| E-6 | Building 9201-1 Site OVA Concentration Contours from Soil Gas Survey..... | E-14 |
| E-7 | Soil Gas Over Fresh Gasoline..... | E-16 |
| E-8 | Soil Gas Over Degraded Gasoline | E-17 |
| E-9 | Diesel/Creosote Mixture..... | E-18 |

LIST OF TABLES

| Table | Title | Page |
|--------------|---|-------------|
| 3-1 | Summary of Well Construction Information for Groundwater Monitoring Wells Located at the Building 9201-1 Site..... | 3-5 |
| 3-2 | QA/QC Sources for the Building 9201-1 Site Activities and Investigations, Oak Ridge Y-12 Plant..... | 3-11 |
| 3-3 | Summary of Quality Assurance/Quality Control Data Generated from Investigation and Sampling Events at the Building 9201-1 Site..... | 3-12 |
| 4-1 | Summary of Groundwater Measurement Information for Groundwater Monitoring Wells Located at the Building 9201-1 Site..... | 4-11 |
| 4-2 | TDEC UST Closure Action Levels for Petroleum Contaminated Groundwater | 4-17 |
| 4-3 | Summary of Significant Analytical Results for Groundwater Samples Collected During Investigations and Sampling Events Conducted at the Building 9201-1 Site | 4-18 |
| 5-1 | TDEC UST Closure Action Levels for Petroleum Contaminated Soils | 5-17 |
| 5-2 | Summary of Significant Analytical Results for Soil Samples Collected During Investigations and Sampling Events Conducted at the Building 9201-1 Site..... | 5-19 |
| 7-1 | Initial Screening of Technologies and Process Options for the Building 9201-1 Site Soil Remediation..... | 7-6 |
| 7-2 | Initial Screening of Technologies and Process Options for the Building 9201-1 Site Groundwater Remediation..... | 7-19 |
| 7-3 | Evaluation of the Selected Process Options for Soil Remediation at the Building 9201-1 Site | 7-41 |
| 7-4 | Evaluation of the Selected Process Options for Groundwater Remediation at the Building 9201-1 Site | 7-49 |
| 7-5 | Technology Specific Requirements of Top Three Soil Corrective Action Options for the Building 9201-1 Site..... | 7-57 |
| 7-6 | Advantages and Disadvantages of Top Three Soil Corrective Action Options for the Building 9201-1 Site..... | 7-56 |
| 7-7 | Projected Remediation Periods of Top Three Soil Corrective Action Options for the Building 9201-1 Site..... | 7-63 |
| 7-8 | Technology Specific Requirements of Top Three Groundwater Corrective Action Options for the Building 9201-1 Site | 7-65 |
| 7-9 | Advantages and Disadvantages of Top Three Groundwater Corrective Action Options for the Building 9201-1 Site | 7-66 |

LIST OF TABLES (continued)

| Table | Title | Page |
|--------------|--|-------------|
| 7-10 | Projected Remediation Periods of Top Three Groundwater Corrective Action Options for the Building 9201-1 Site | 7-70 |
| 8-1 | Volume Calculation for the Building 9201-1 Site Corrective Action Plan Average End Area Method..... | 8-7 |
| 8-2 | Analytical Methods Proposed for Analyses of Remediation Soil and Groundwater Samples Collected at the Building 9201-1 Site | 8-9 |
| 11-1 | Health and Safety Information Concerning Possible Hazardous/Toxic Contaminants at the Building 9201-1 Site | 11-3 |
| D.1-1 | Analytical Results for Soil Samples Collected for the Initial Site Characterization of the Building 9201-1 Site | D-3 |
| D.2-1 | Analytical Results for Surface Water Samples Collected for the Initial Site Characterization of the Building 9201-1 Site | D-11 |
| E-1 | Site Specific Parameters and Considerations for Interpretation of Soil Gas Surveys | E-3 |
| E-2 | Soil Gas Survey Analytical Results..... | E-6 |
| F.1-1 | Analytical Results for Soil Samples Collected for the Site Investigation of the Building 9201-1 Site..... | F-3 |
| F.2-1 | Analytical Results for Groundwater Samples Collected for the Site Investigation of the Building 9201-1 Site..... | F-10 |
| G.1-1 | Analytical Results for Groundwater Samples Collected for the 1990 Y-12 Plant Groundwater Quality Assessment Report of the Building 9201-1 Site..... | G-3 |
| G.2-1 | Analytical Results for Groundwater Samples Collected for the 1991 Y-12 Plant Groundwater Quality Assessment Report at the Building 9201-1 Site | G-8 |

PROFESSIONAL GEOLOGIST AFFIRMATION

I, Christopher David Potter, a Professional Geologist currently registered by the State of Tennessee, was responsible for the preparation and/or immediate personal supervision of the entire Environmental Assessment (Part I: Sections 1.0, 2.0, 3.0, 4.0, and 5.0) presented in this document. All of the historical information, descriptions of site investigation activities, and analytical data used for the preparation of the Environmental Assessment presented herein were provided by Martin Marietta Energy Systems, Inc., Y-12 Plant Underground Storage Tank Program, Environmental Management Department, which is responsible for the content and accuracy of the original information and data provided.

I do hereby affirm that the information contained in the Environmental Assessment part of this document is accurate and correct to the best of my knowledge and belief and is consistent with the generally accepted standards of my profession.

Christopher David Potter

Name

9/29/93

Date

Senior Hydrogeologist

Title

TN 2345

TN License Number

[Handwritten Signature]

Signature



REGISTERED ENGINEER AFFIRMATION

I, Robin Duane Adkison, a Registered Engineer currently licensed by the State of Tennessee, was responsible for the preparation and/or immediate personal supervision of the entire Corrective Action Plan (Part II: Sections 6.0, 7.0, 8.0, 9.0, 10.0, 11.0, 12.0, and 13.0) presented in this document. All of the historical information, descriptions of site investigation activities, and analytical data used for the preparation of the Corrective Action Plan presented herein were provided by Martin Marietta Energy Systems, Inc., Y-12 Plant Underground Storage Tank Program, Environmental Management Department, which is responsible for the content and accuracy of the original information and data provided.

I do hereby affirm that the information contained in the Corrective Action Plan part of this document is accurate and correct to the best of my knowledge and belief and is consistent with the generally accepted standards of my profession.

Robin D. Adkison

Name

9-29-93

Date

Environmental Engineer

Title

16222

TN License Number

Robin D. Adkison

Signature



EXECUTIVE SUMMARY

This document represents the Corrective Action Plan for underground storage tank (UST) 2331-U, previously located at Building 9201-1, Oak Ridge Y-12 Plant, Oak Ridge, Tennessee. Tank 2331-U, a 560-gallon UST, was removed on December 14, 1988. This document presents a comprehensive summary of all environmental assessment investigations conducted at the Building 9201-1 Site and the corrective action measures proposed for remediation of subsurface petroleum product contamination identified at the site. This document is written in accordance with the regulatory requirements of the Tennessee Department of Environment and Conservation (TDEC) Rule 1200-1-15-.06(7).

Based on the determination that groundwater at the Building 9201-1 Site is classified as a non-drinking water source, the applicable TDEC Closure Action Levels for remediation of petroleum contaminated groundwater at the facility are 0.070 ppm for benzene and 1.0 ppm for total petroleum hydrocarbons (TPH). Analytical results for groundwater samples collected during investigations at the Building 9201-1 Site suggest that an area of groundwater contamination exceeding applicable action levels, and measuring approximately 2,300 ft², extends from the Building 9201-1 former tank pit east/southeast toward Building 9105.

Based on the non-drinking water source classification for groundwater at the Building 9201-1 Site and analysis of slug testing data, which indicates that soil permeabilities at the facility range between 10⁻⁴ to 10⁻⁶ cm/sec, the applicable TDEC Closure Action Levels for remediation of petroleum contaminated soils at the facility are 250 ppm for total benzene, toluene, and xylenes (BTX) and 500 ppm for TPH. Analytical results for soil samples collected during investigations at the Building 9201-1 Site suggest that no soil samples collected outside the tank pit possess contamination in excess of 250 ppm total BTX. Grab samples collected within the tank bay during tank removal, however, do show contamination in excess of the applicable TDEC Closure Action Level. At the time of the soil characterization effort, no TPH analysis was required by TDEC; as a result, no delineation of TPH-contaminated soil is shown. TPH analysis will be performed as part of confirmatory soil sampling for the corrective action. A volume of approximately 130 yd³ of soil located around the underground storage tank bay at Building 9201-1 constitutes the contaminated soil identified for removal and remediation.

A wide variety of corrective action responses and options were evaluated for possible remediation of petroleum contaminated soils and groundwater at the Building 9201-1 Site. The recommended corrective action approach for groundwater involves extraction of contaminated groundwater

through recovery wells, treatment at Y-12 wastewater treatment facilities, and release of treated groundwater into Y-12 surface waters at NPDES-permitted discharge points. Based on screening criteria established for the evaluation process, a combination of corrective action options was selected to accomplish soil remediation at the facility. The recommended corrective action approach for soils at the Building 9201-1 Site involves initial excavation and confirmatory sampling of contaminated soils from impacted areas, onsite thermal desorption, and final disposal of the treated soils in the subject site excavation or at a permitted Y-12 landfill facility.

Confirmatory soil samples will be collected for laboratory analysis during excavation activities in order to ensure that remediation of the Building 9201-1 Site is complete. Progress and post-treatment soil and groundwater samples will be collected from the site in order to monitor the effectiveness of treatment and to ensure compliance with TDEC regulatory requirements.

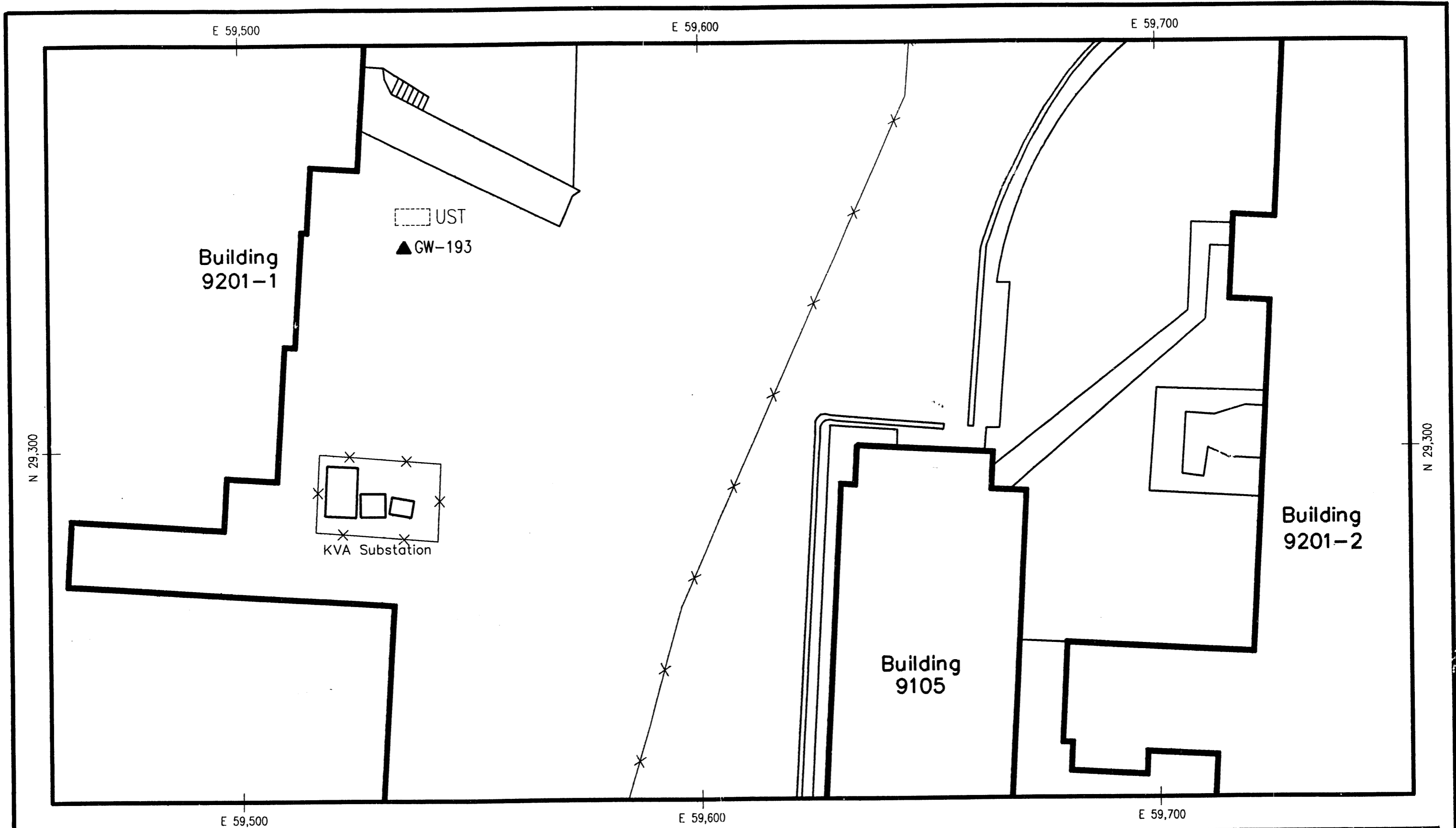

All location information presented in this figure is based upon MMES engineering drawings, results of previous MMES investigations, and/or field determinations of feature and sampling locations. No representation or warranty, expressed or implied, is made as to the accuracy of the information or statements presented in this figure.

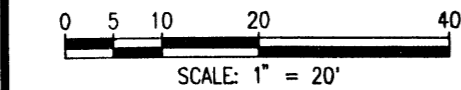

REVISION 1 (7-30-93)
G:\93021R1\DWGS\4313-2

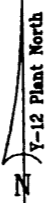

Legend

▲ GW-193 Monitoring Well Location

Martin Marietta Energy Systems, Inc.
Environmental Management Department

FIGURE 3-2
Building 9201-1 Site
Free Product Removal
Recovery/Monitoring Well Location

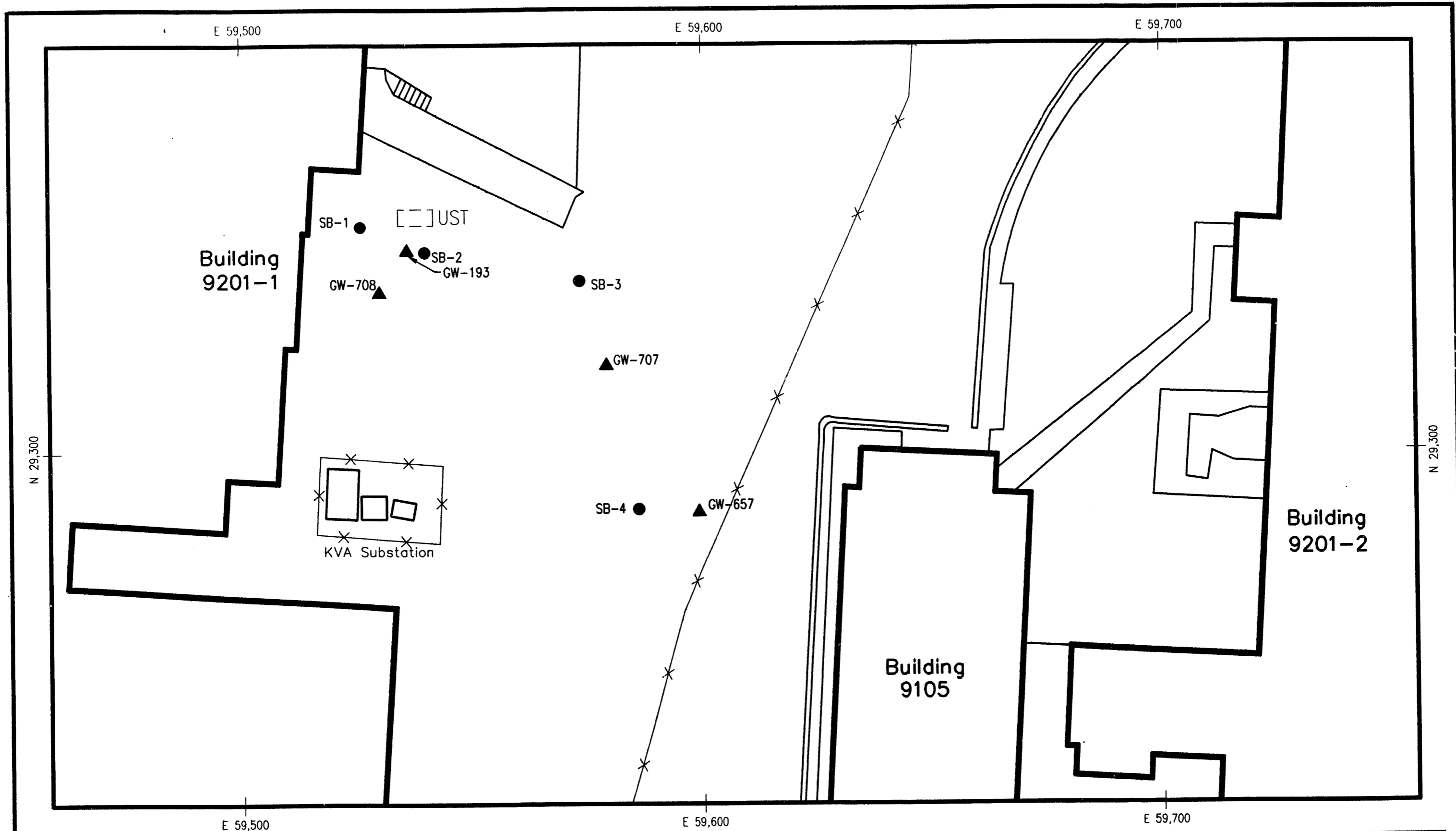

All location information presented in this figure is based upon MMES engineering drawings, results of previous MMES investigations, and/or field determinations of feature and sampling locations. No representation or warranty, expressed or implied, is made as to the accuracy of the information or statements presented in this figure.

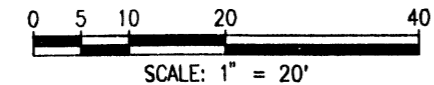

REVISION 1 (7-30-93)
G:\93021R1\DWGS\4313-3



Legend

- ▲ GW-193 Groundwater Monitoring Well Locations
- SB-1 Soil Sampling Borehole Locations

Martin Marietta Energy Systems, Inc.
Environmental Management Department

FIGURE 3-3
Building 9201-1 Site Investigation
Soil Boring and Monitor Well Locations

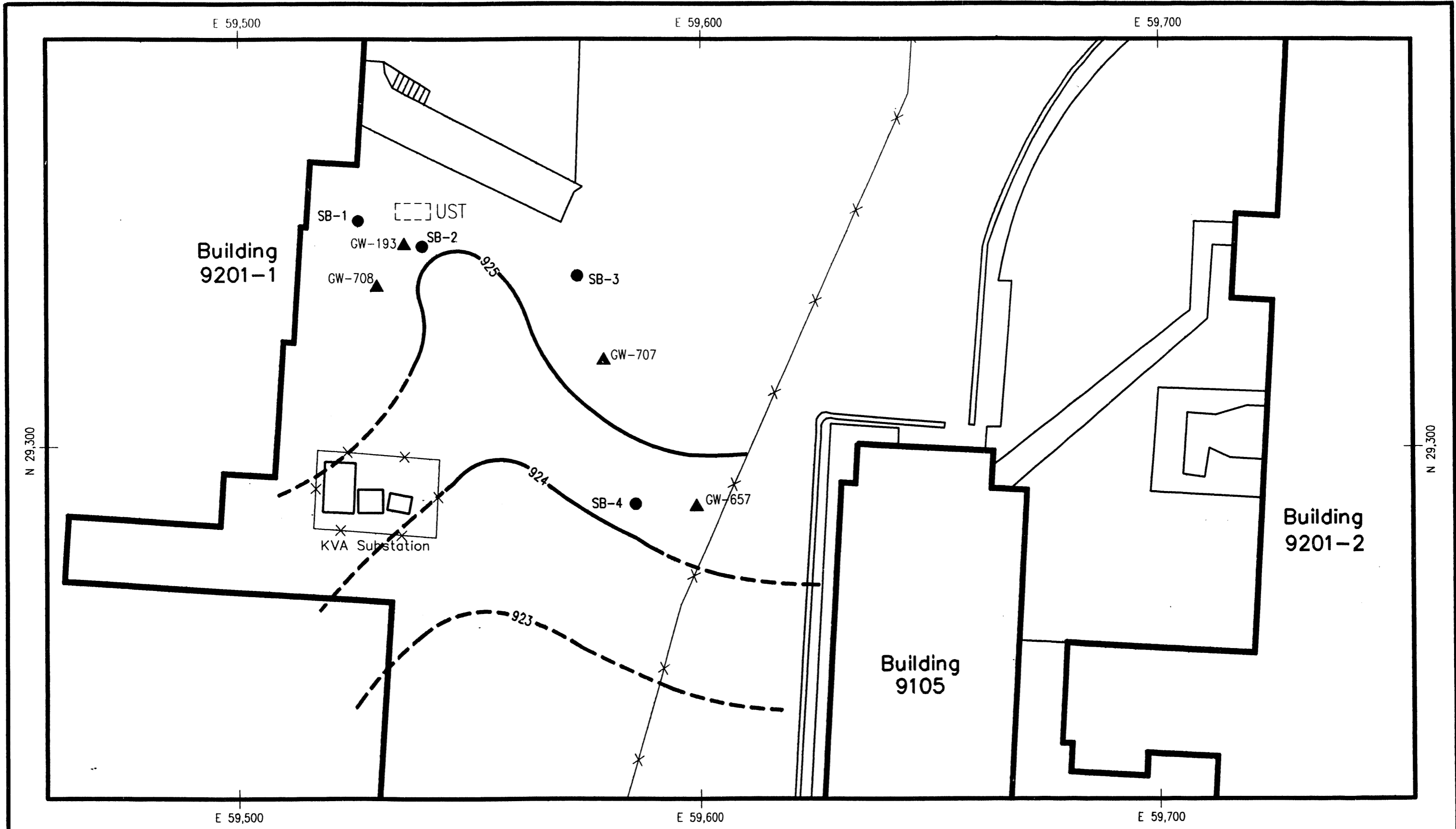

All location information presented in this figure is based upon MMES engineering drawings, results of previous MMES investigations, and/or field determinations of feature and sampling locations. No representation or warranty, expressed or implied, is made as to the accuracy of the information or statements presented in this figure.

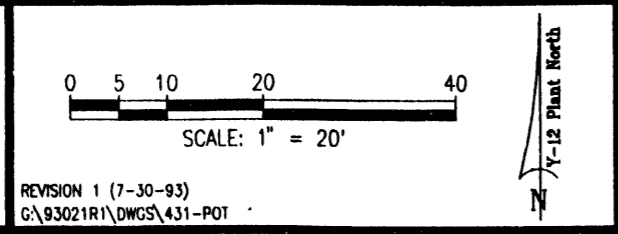

REVISION 1 (7-30-93)
G:\93021R1\DWGS\431-POT

Legend

- 925 — Groundwater Potentiometric Contour Line (Feet Above MSL)
- - 924 - - Inferred Groundwater Potentiometric Contour Line (Feet Above MSL)
- ▲ GW-193 Groundwater Monitoring Well Locations
- SB-1 Soil Sampling Borehole Locations

Martin Marietta Energy Systems, Inc.
Environmental Management Department
FIGURE 4-5
Building 9201-1
Site Groundwater Potentiometric
Contour Map for May/June

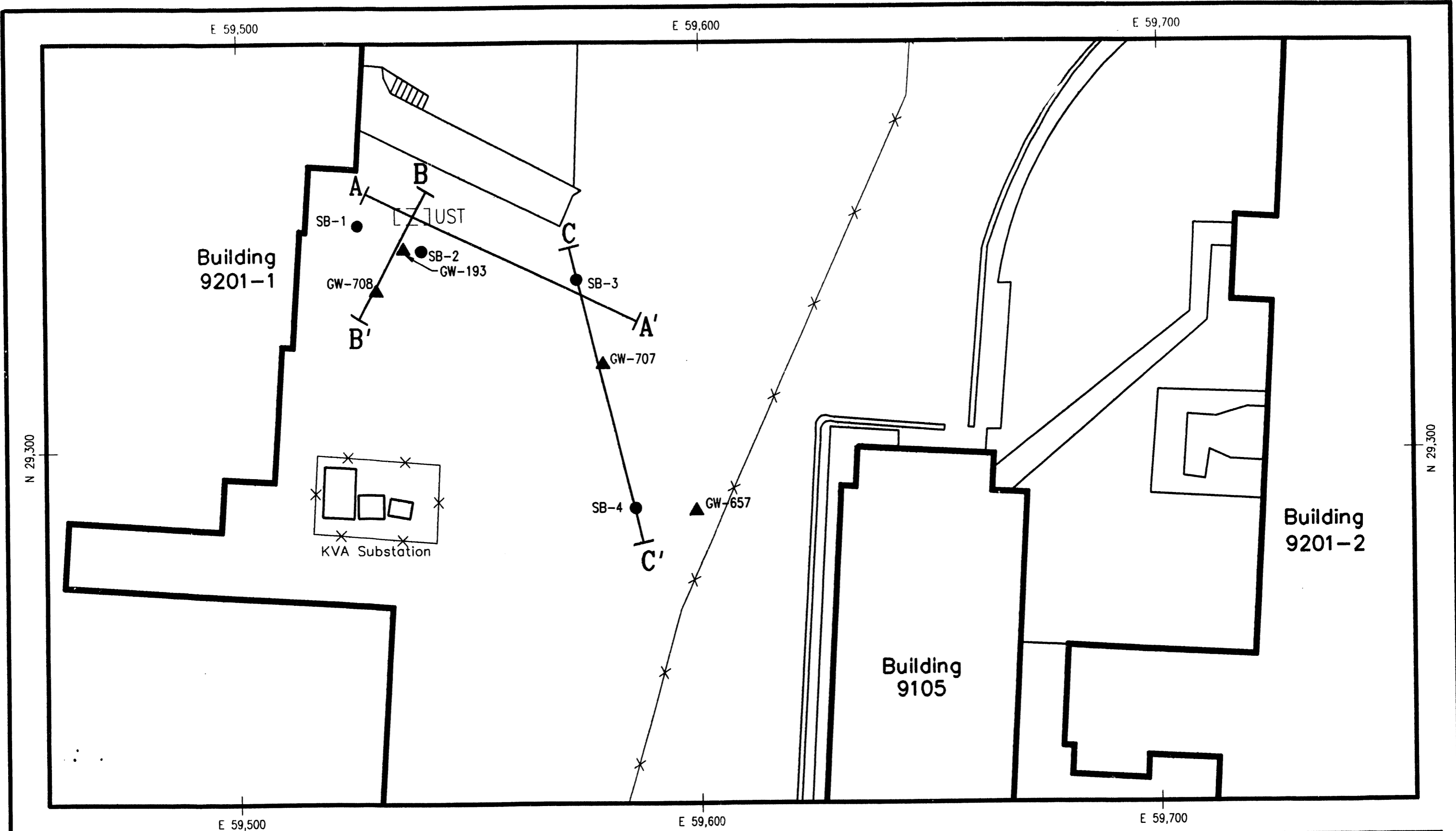

All location information presented in this figure is based upon MMES engineering drawings, results of previous MMES investigations, and/or field determinations of feature and sampling locations. No representation or warranty, expressed or implied, is made as to the accuracy of the information or statements presented in this figure.

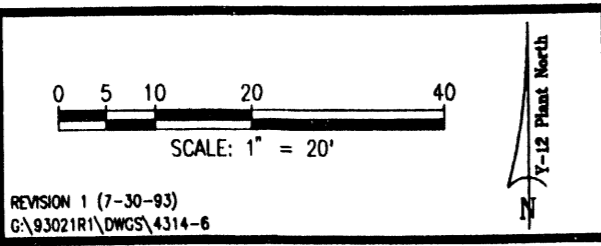

| Legend | |
|----------|---------------------------------------|
| ▲ GW-193 | Groundwater Monitoring Well Locations |
| ● SB-1 | Soil Sampling Borehole Locations |

Martin Marietta Energy Systems, Inc.
Environmental Management Department
FIGURE 4-6
Building 9201-1 Site Groundwater Cross-Section, Borehole, and Monitoring Well Locations



All location information presented in this figure is based upon MMES engineering drawings, results of previous MMES investigations, and/or field determinations of feature and sampling locations. No representation or warranty, expressed or implied, is made as to the accuracy of the information or statements presented in this figure.

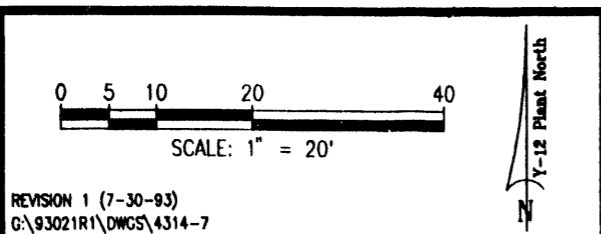

| Legend | |
|-------------------|--|
| ● SB-1 | Soil Sampling Borehole Locations |
| ▲ GW-193 | Groundwater Monitoring Well Locations |
| ▣ (cross-hatched) | Groundwater Contamination >0.07ppm Benzene & >1.0ppm TPH |



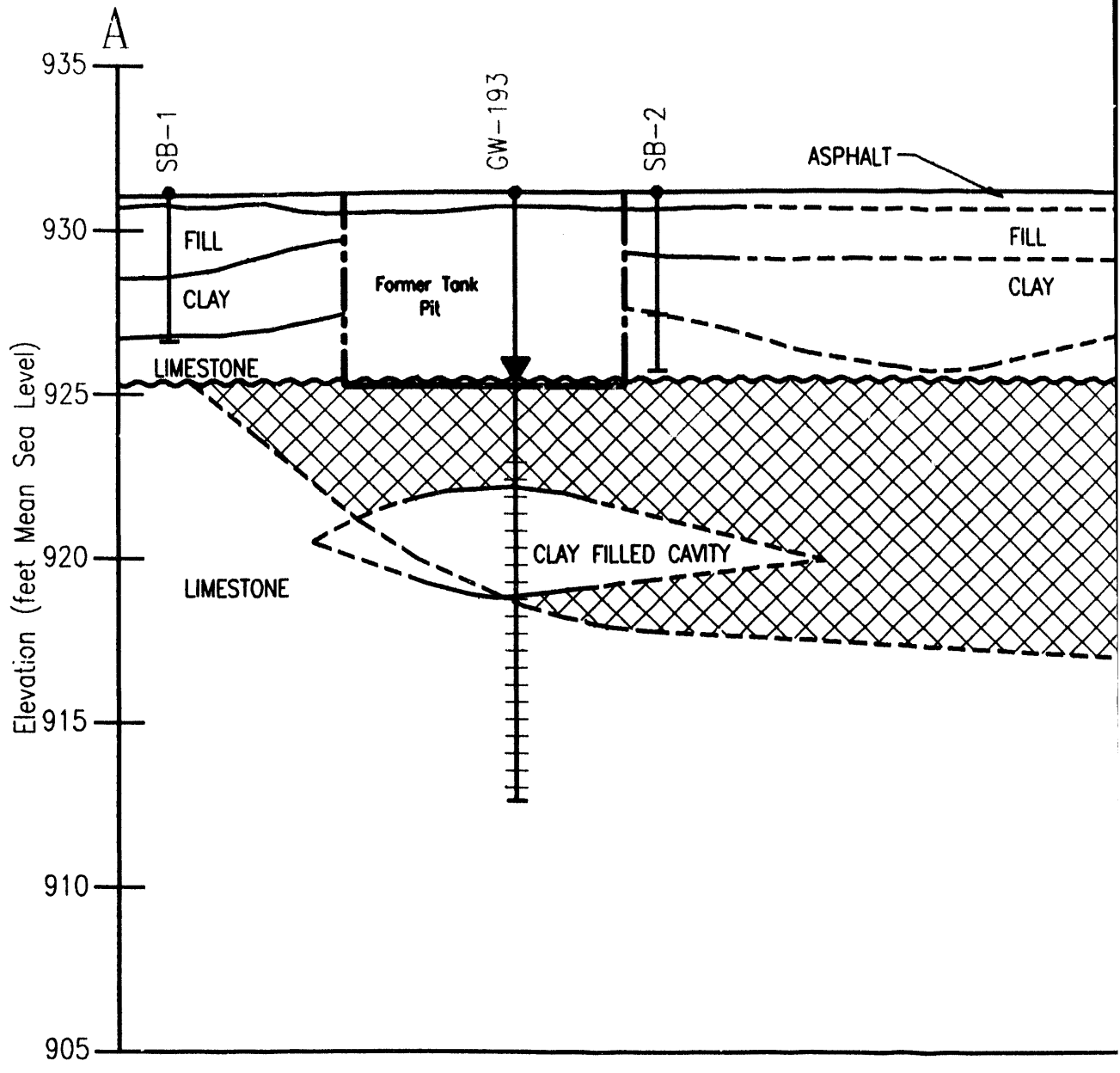

Martin Marietta Energy Systems, Inc.
Environmental Management Department

FIGURE 4-7
Horizontal Extent of Groundwater Benzene & TPH Contamination at the Building 9201-1 Site



All location information presented in this figure is based upon MMES engineering drawings, results of previous MMES investigations, and/or field determinations of feature and sampling locations. No representation or warranty, expressed or implied, is made as to the accuracy of the information or statements presented in this figure.

REVISION 1 (8-2-93)
 G:\93021R1\DWGS\431A-A

| LEGEND | |
|---|-----------------------|
|  | Groundwater >0.07 ppr |
|  | Former Tank Pit Bound |
|  | GW-193 Groundwater |
|  | SB-04 Soil Sample |

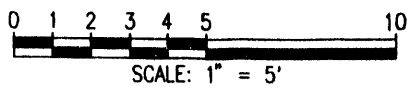

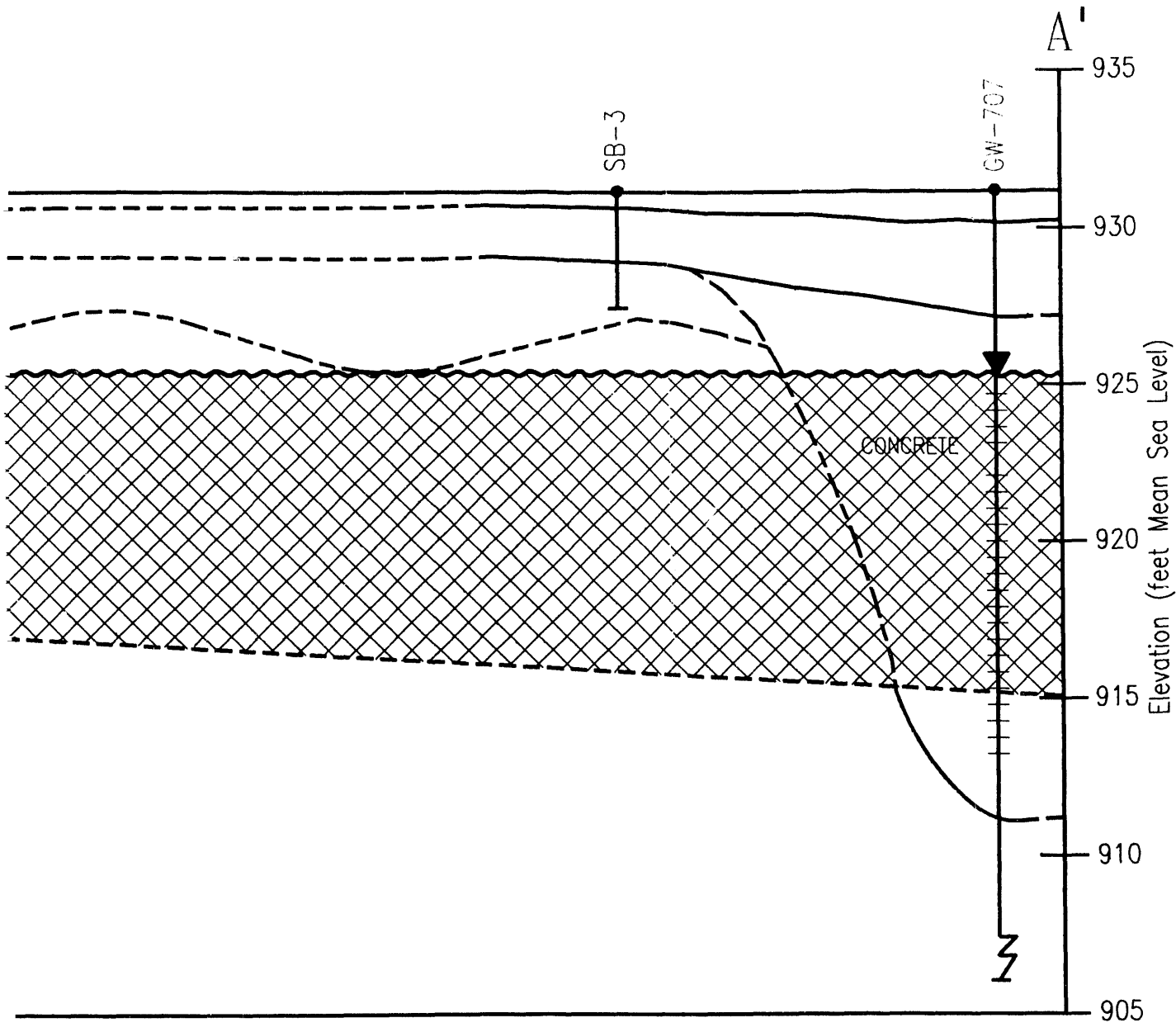

Contamination
Benzene and >1.0 ppm TPH

Isotopes

Monitoring Well Locations

Monitoring Borehole Locations

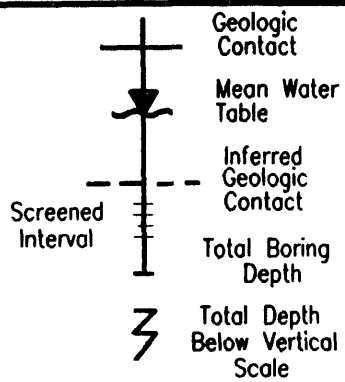

Martin Marietta Energy Systems, Inc.
Environmental Management Department

FIGURE 4-8

**Building 9201-1 Site Vertical
Extent of Groundwater Contamination
Along Cross-Section A-A'**

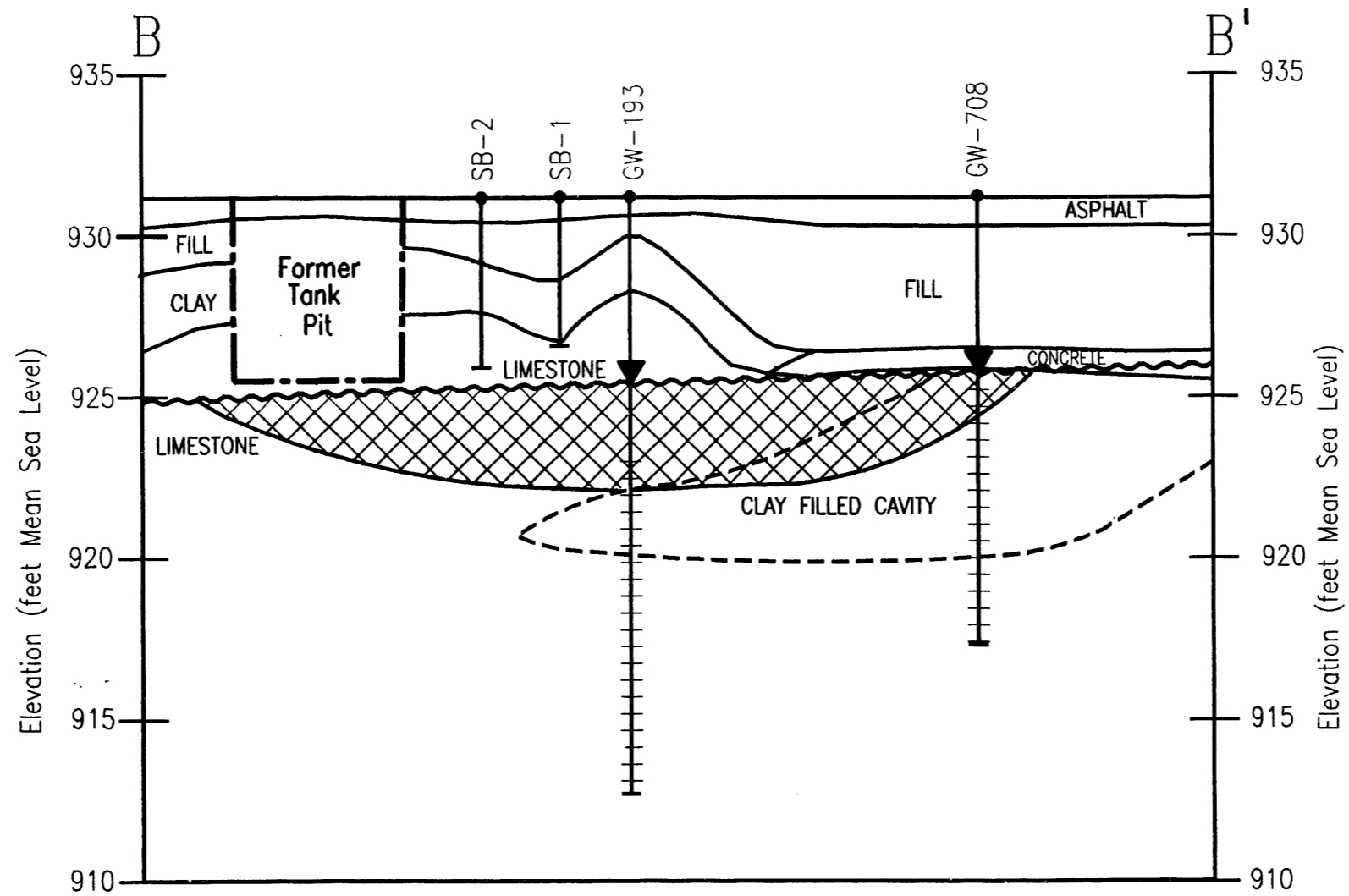



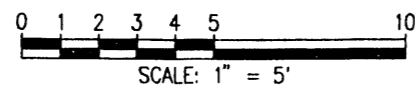







All location information presented in this figure is based upon MMES engineering drawings, results of previous MMES investigations, and/or field determinations of feature and sampling locations. No representation or warranty, expressed or implied, is made as to the accuracy of the information or statements presented in this figure.

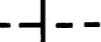

REVISION 1 (8-5-93)
G:\93021R1\DWGS\431B-GW

LEGEND

-  Groundwater Contamination >0.07 ppm Benzene and >1.0 ppm TPH
-  Former Tank Pit Boundaries
-  GW-193 Groundwater Monitoring Well Locations
-  SB-04 Soil Sampling Borehole Locations

-  Geologic Contact
-  Mean Water Table
-  Inferred Geologic Contact
-  Total Boring Depth
-  Total Depth Below Vertical Scale
-  Screened Interval

Martin Marietta Energy Systems, Inc.
Environmental Management Department

FIGURE 4-9
Building 9201-1 Site Vertical
Extent of Groundwater Contamination
Along Cross-Section B-B'

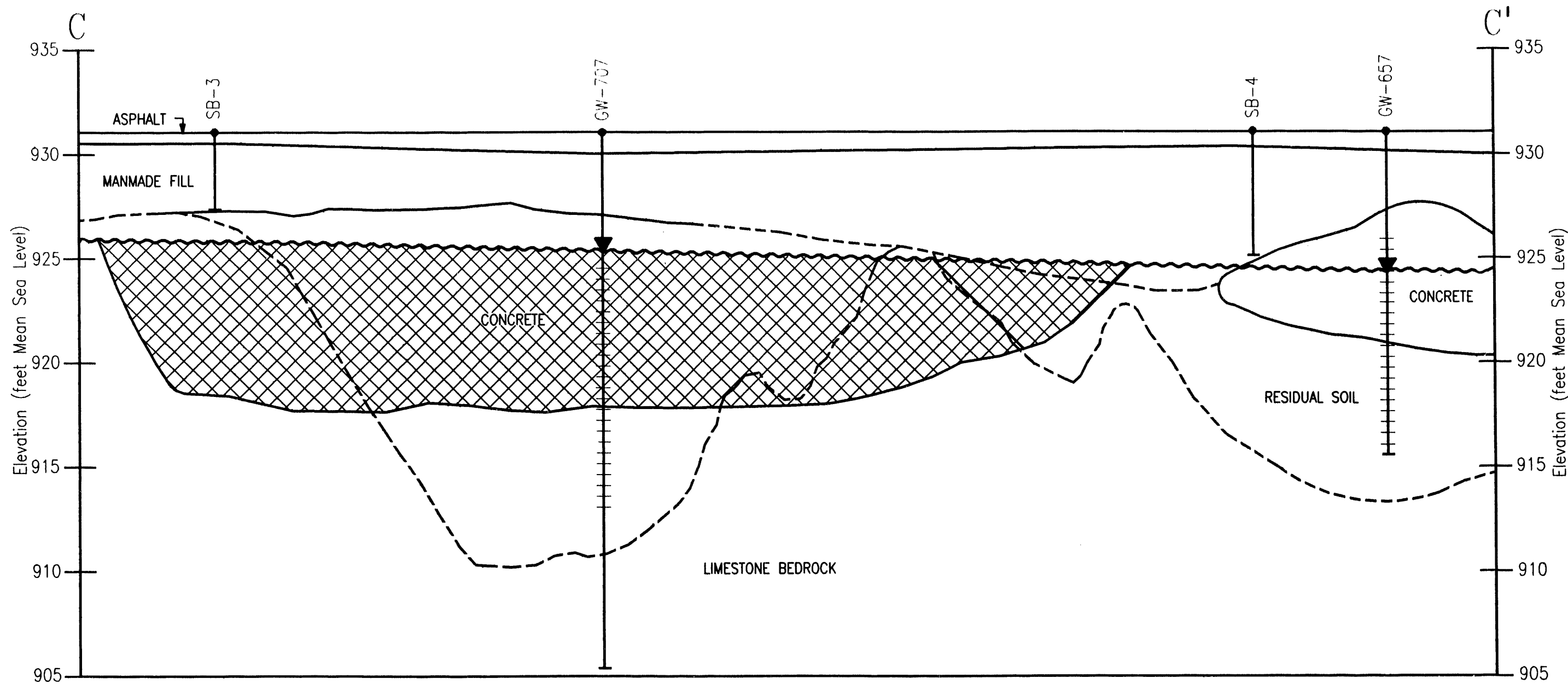

All location information presented in this figure is based upon MMES engineering drawings, results of previous MMES investigations, and/or field determinations of feature and sampling locations. No representation or warranty, expressed or implied, is made as to the accuracy of the information or statements presented in this figure.

REVISION 1 (8-6-93)
G:\93021R1\DWGS\431C-GW

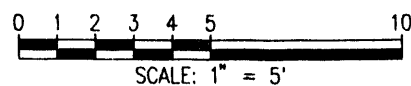

LEGEND



Groundwater Contamination
>0.07 ppm Benzene and >1.0 ppm TPH

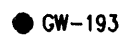

GW-193 Groundwater Monitoring Well Locations

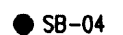

SB-04 Soil Sampling Borehole Locations

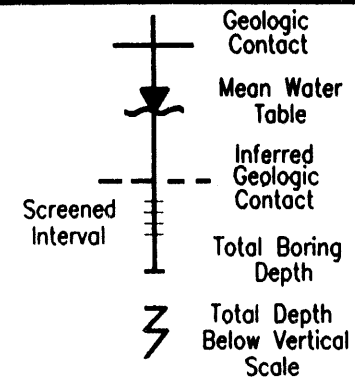

Martin Marietta Energy Systems, Inc.
Environmental Management Department

FIGURE 4-10
Building 9201-1 Site Vertical
Extent of Groundwater Contamination
Along Cross-Section C-C'

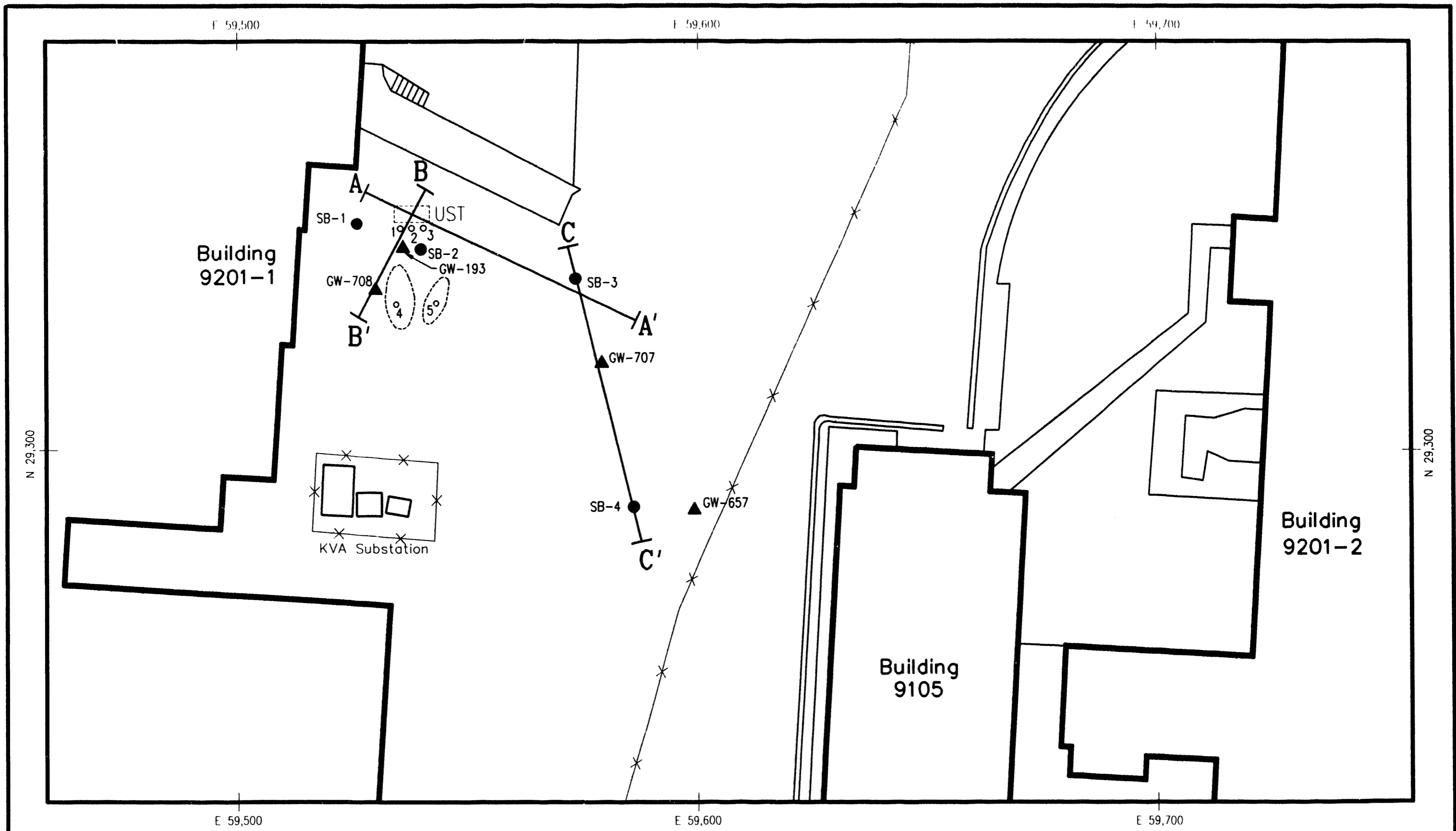

All location information presented in this figure is based upon MMES engineering drawings, results of previous MMES investigations, and/or field determinations of feature and sampling locations. No representation or warranty, expressed or implied, is made as to the accuracy of the information or statements presented in this figure.

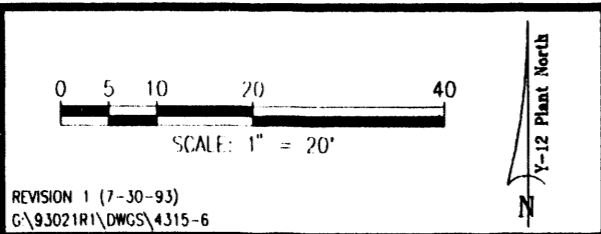

| Legend | |
|------------|---------------------------------------|
| ▲ GW-193 | Groundwater Monitoring Well Locations |
| ● SB-1 | Soil Sampling Borehole Locations |
| ○ (dashed) | Former Spoil Pile Location |
| ○ (solid) | Soil Grab Sample Location |

Martin Marietta Energy Systems, Inc.
 Environmental Management Department
FIGURE 5-6
Building 9201-1 Site Soil Cross-Section, Borehole, Grab Sample and Monitoring Well Locations

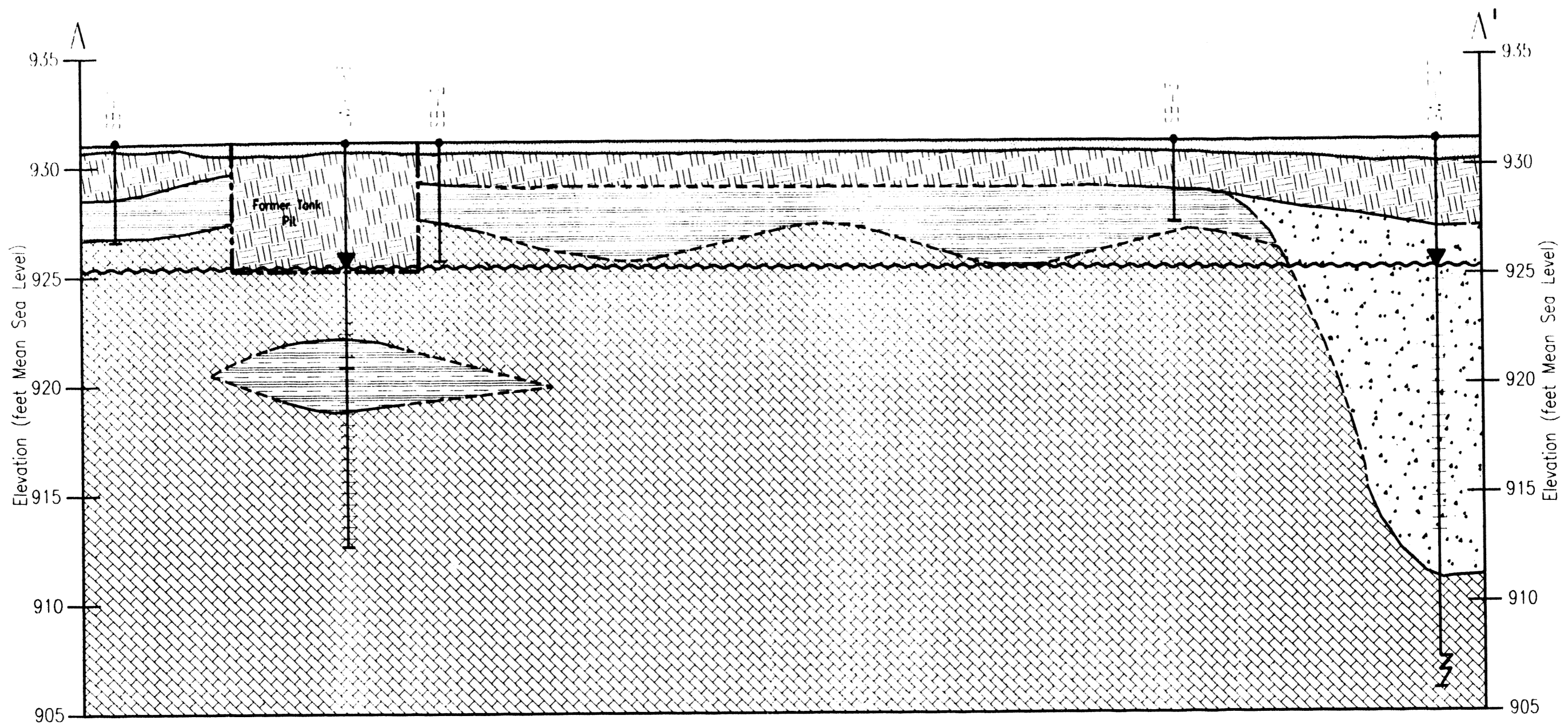

All location information presented in this figure is based upon MMES engineering drawings, results of previous MMES investigations, and/or field determinations of feature and sampling locations. No representation or warranty, expressed or implied, is made as to the accuracy of the information or statements presented in this figure.

REVISION 1 (8-2-93)
G:\93021R1\DWGS\431A-GEO

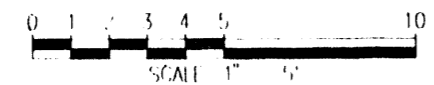

LEGEND

- | | | | | | |
|--|---------------|--|--------------------------|--|----------------------------------|
| | Asphalt | | Concrete | | Geologic Contact |
| | Manmade Fill | | Clay Filled Cavity | | Mean Water Table |
| | Residual Soil | | Limestone Bedrock | | Inferred Geologic Contact |
| | | | Former Tank Pit Boundary | | Total Boring Depth |
| | | | | | Total Depth Below Vertical Scale |

Martin Marietta Energy Systems, Inc.
Environmental Management Department

FIGURE 5-7
Building 9201-1 Site
Geologic Cross-Section A-A'

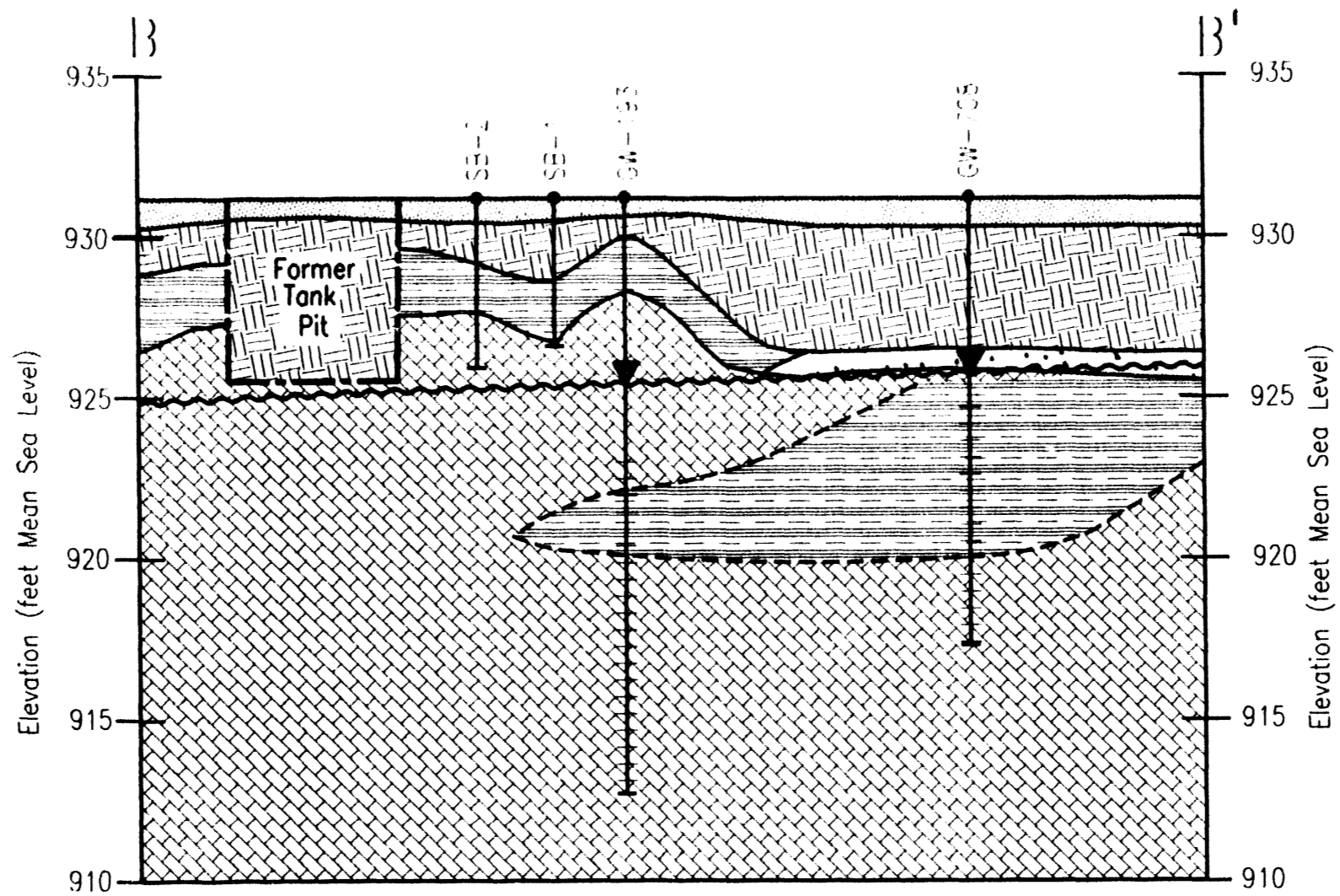

All location information presented in this figure is based upon MMES engineering drawings, results of previous MMES investigations, and/or field determinations of feature and sampling locations. No representation or warranty, expressed or implied, is made as to the accuracy of the information or statements presented in this figure.

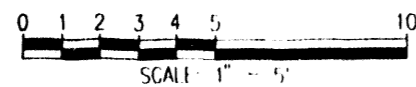

REVISION 1 (8-5-93)
G:\93021R1\DWGS\431B-G10

LEGEND



Asphalt
Manmade Fill
Residual Soil



Concrete
Clay Filled Cavity
Limestone Bedrock
Former Tank Pit Boundaries

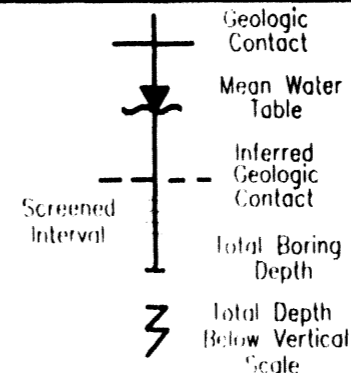

Geologic Contact
Mean Water Table
Inferred Geologic Contact
Screened Interval
Total Boring Depth
Total Depth Below Vertical Scale

Martin Marietta Energy Systems, Inc.
Environmental Management Department

FIGURE 5-8
Building 9201-1 Site
Geologic Cross-Section B-B'

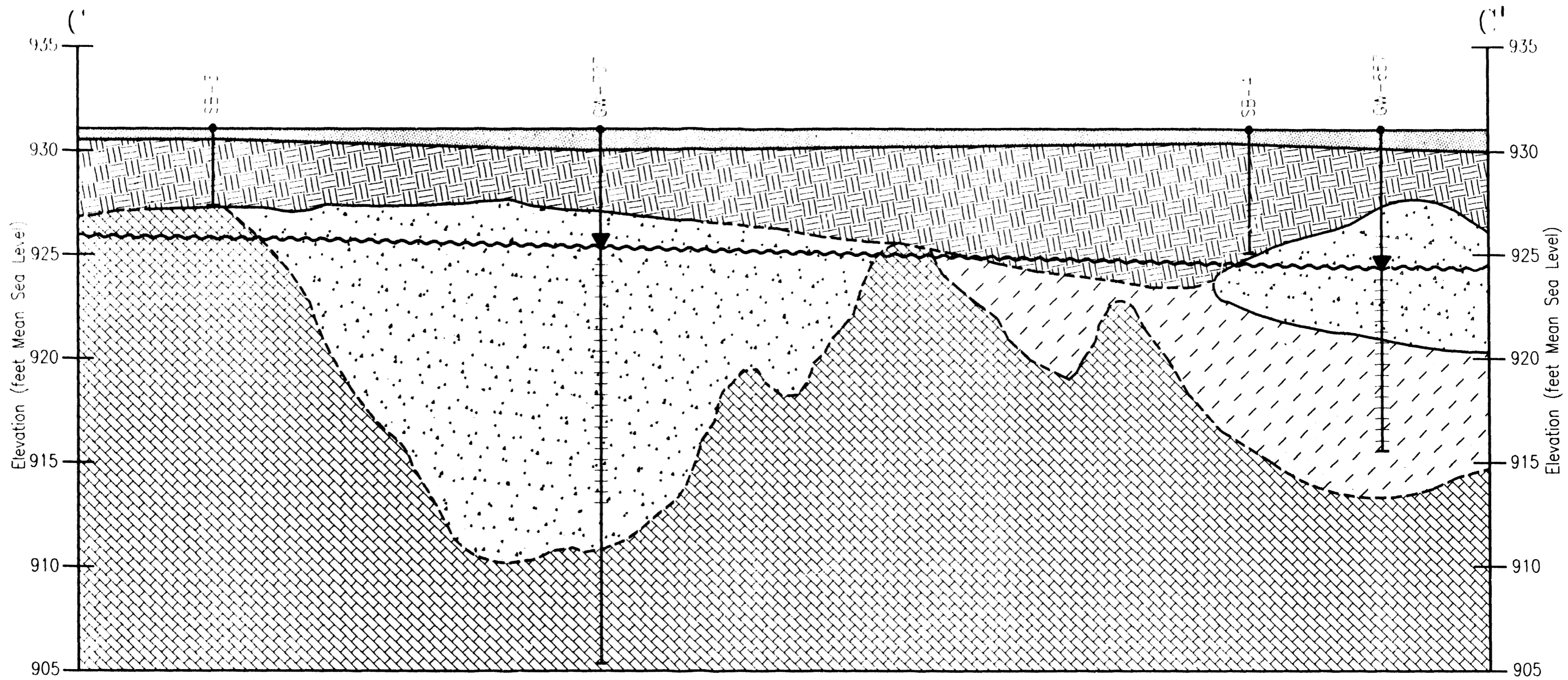

All location information presented in this figure is based upon MMES engineering drawings, results of previous MMES investigations, and/or field determinations of feature and sampling locations. No representation or warranty, expressed or implied, is made as to the accuracy of the information or statements presented in this figure.

REVISION 1 (8-6-93)
G:\93021R1\DWGS\431C.GEO

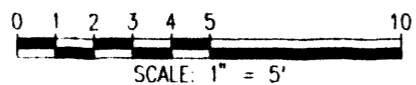

LEGEND

- | | | | |
|--|---------------|--|--------------------|
| | Asphalt | | Concrete |
| | Manmade Fill | | Clay Filled Cavity |
| | Residual Soil | | Limestone Bedrock |

- | | |
|--|----------------------------------|
| | Geologic Contact |
| | Mean Water Table |
| | Inferred Geologic Contact |
| | Total Boring Depth |
| | Total Depth Below Vertical Scale |

Martin Marietta Energy Systems, Inc.
Environmental Management Department

FIGURE 5-9
Building 9201-1 Site
Geologic Cross-Section C-C'

E 59,500

E 59,600

N 29,300

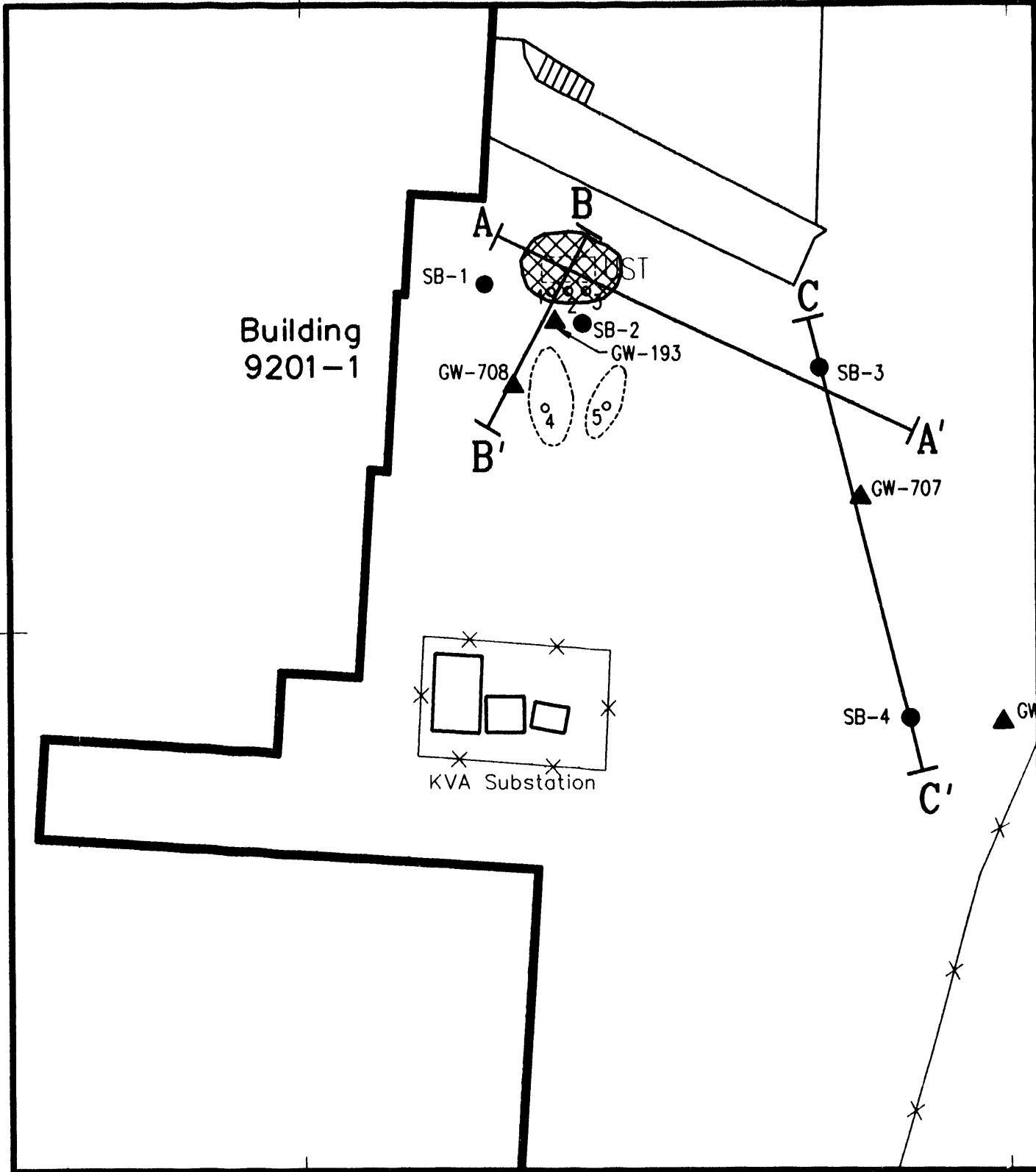

Building 9201-1

KVA Substation

All location information presented in this figure is based upon MMES engineering drawings, results of previous MMES investigations, and/or field determinations of feature and sampling locations. No representation or warranty, expressed or implied, is made as to the accuracy of the information or statements presented in this figure.

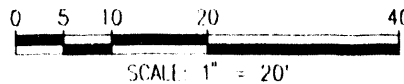

REVISION 1 (7-30-93)
G:\93021R1\DWGS\4315-10

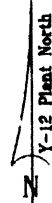

Legend



Soil Contamination
>250 ppm BTX



Former Spoil Pile Location

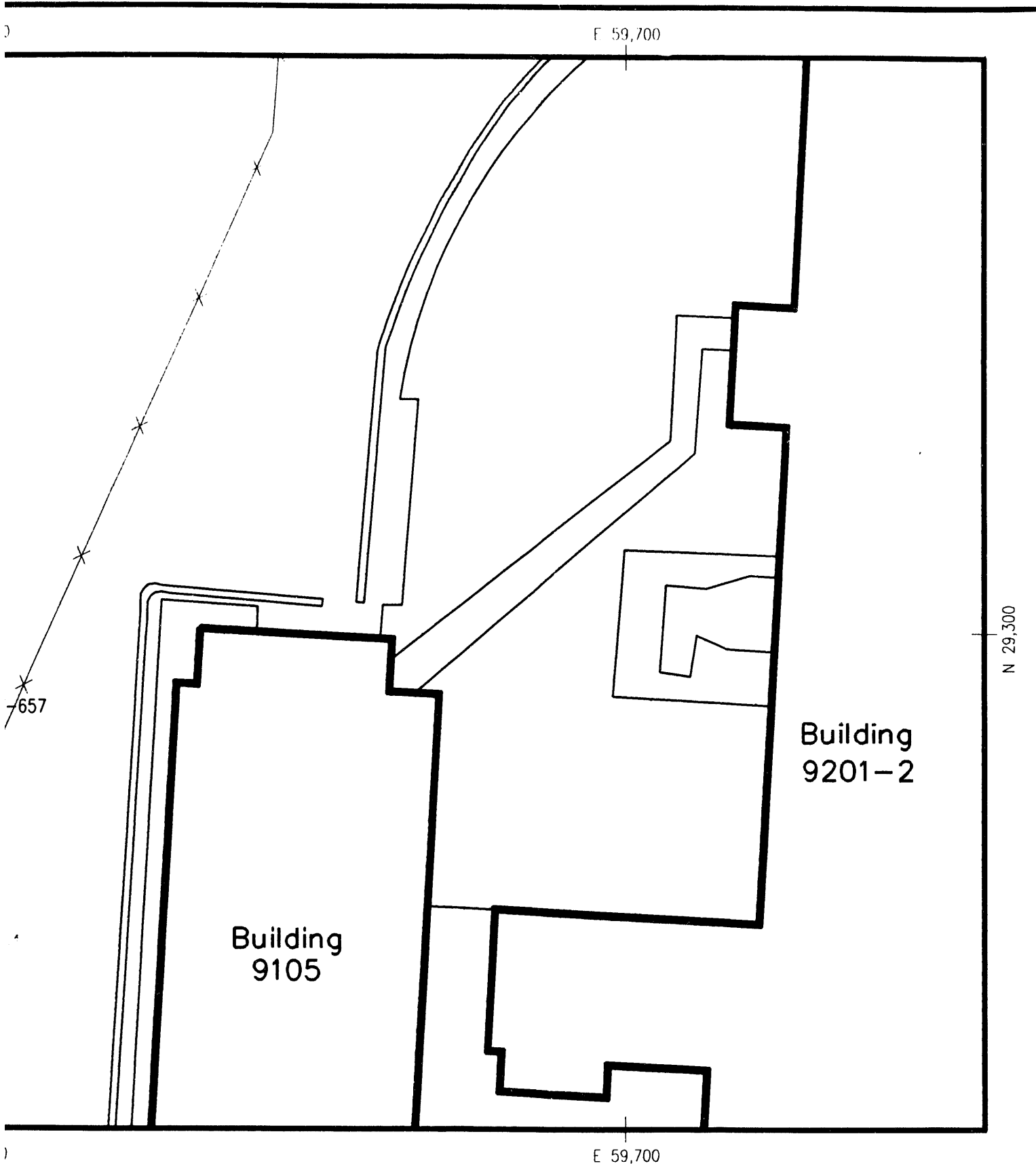

- ▲ GW-193 Groundwater Monitoring Well Locations
- SB-1 Soil Sampling Borehole Locations
- Soil Grab Sample Location

Martin Marietta Energy Systems, Inc.
Environmental Management Department

FIGURE 5-10

**Building 9201-1
Composite Soil Contamination Map**

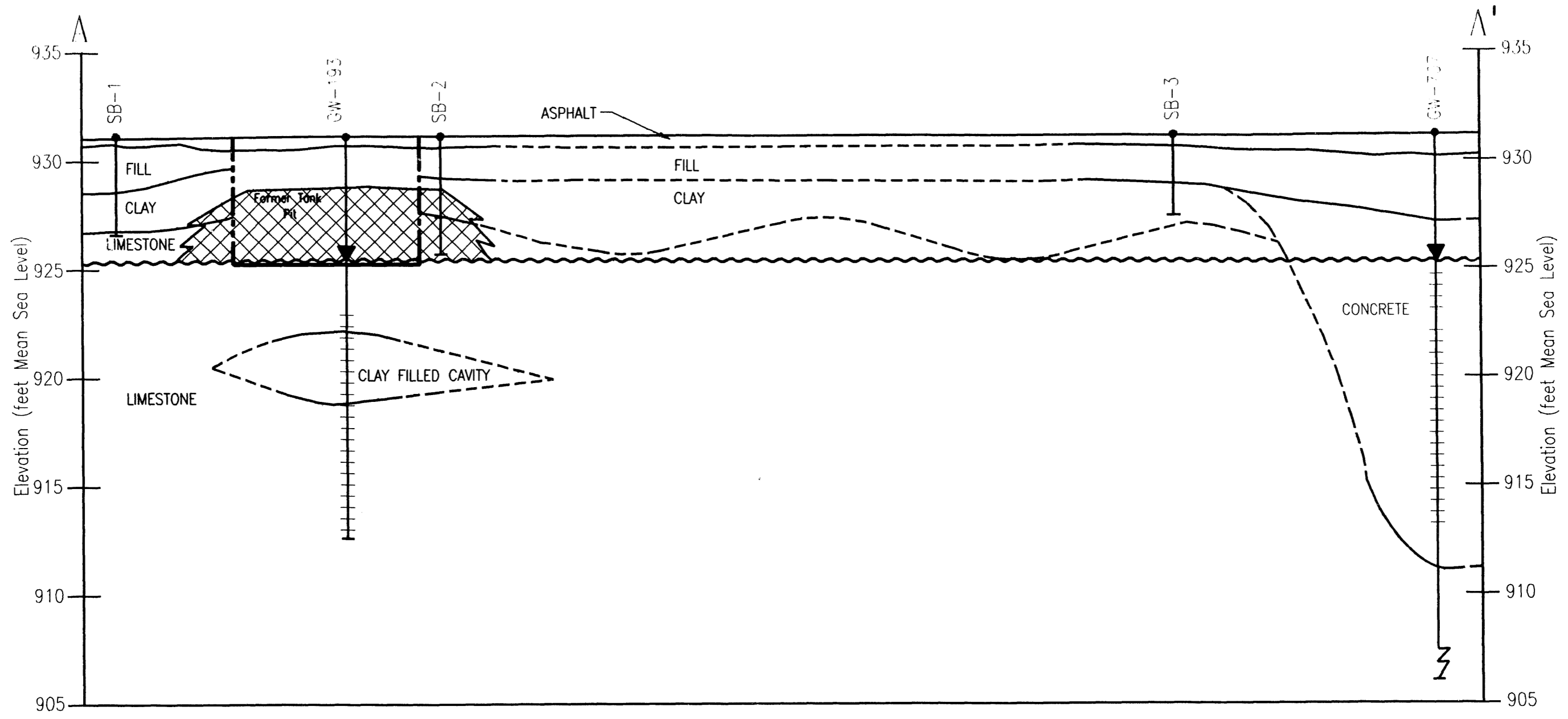

All location information presented in this figure is based upon MMES engineering drawings, results of previous MMES investigations, and/or field determinations of feature and sampling locations. No representation or warranty, expressed or implied, is made as to the accuracy of the information or statements presented in this figure.

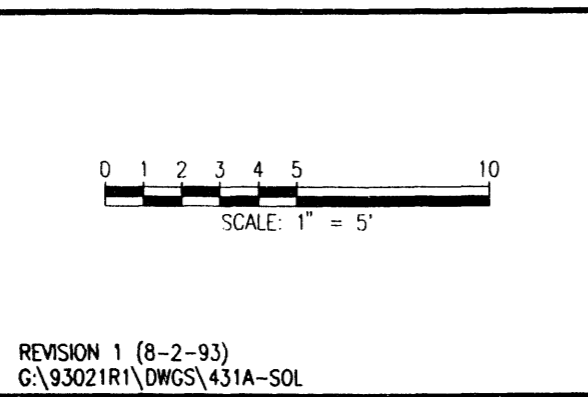

LEGEND

- Soil Contamination >250 ppm BTX
- Former Tank Pit Boundaries
- GW-193 Groundwater Monitoring Well Locations
- SB-04 Soil Sampling Borehole Locations

Martin Marietta Energy Systems, Inc.
Environmental Management Department

FIGURE 5-11
Building 9201-1 Site Vertical
Extent of Soil Contamination
Along Cross-Section A-A'

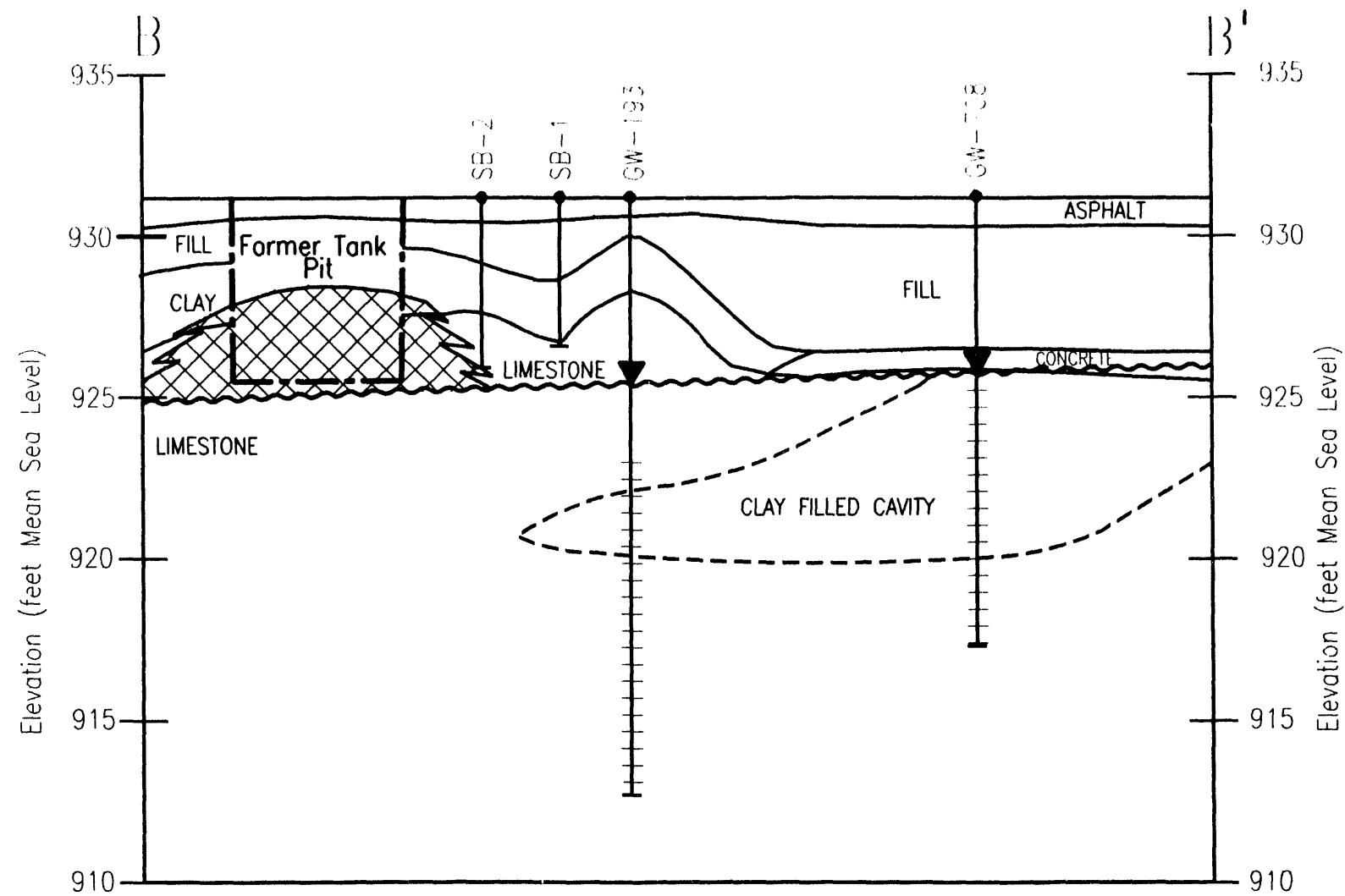





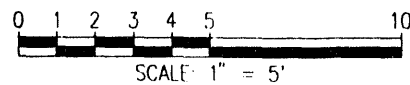





All location information presented in this figure is based upon MMES engineering drawings, results of previous MMES investigations, and/or field determinations of feature and sampling locations. No representation or warranty, expressed or implied, is made as to the accuracy of the information or statements presented in this figure.

REVISION 1 (8-5-93)
G:\93021R1\DWGS\431B-S01



LEGEND

-  Soil Contamination >250 ppm BTX
-  Former Tank Pit Boundaries
-  GW-193 Groundwater Monitoring Well Locations
-  SB-04 Soil Sampling Borehole Locations

-  Geologic Contact
-  Mean Water Table
-  Inferred Geologic Contact
-  Total Boring Depth
-  Total Depth Below Vertical Scale
-  Screened Interval

Martin Marietta Energy Systems, Inc.
Environmental Management Department

FIGURE 5-12
Building 9201-1 Site Vertical
Extent of Soil Contamination
Along Cross-Section B-B'

7.0 CORRECTIVE ACTIONS CONSIDERED

This section describes the screening of remedial technologies and the development of the top three corrective action options for the Building 9201-1 Site. The identification and screening of technologies initially establishes a wide range of process options for consideration. Corrective action objectives are established based on the preferred remediation actions. A screening process on the basis of established criteria is conducted for the soil and groundwater. Process options that are not applicable to petroleum contamination are eliminated. Using this method, the field of potential process options can be narrowed down to the most feasible and reliable technologies. The process options are assembled and developed into potential corrective action options. The potential corrective action options are further evaluated on the basis of effectiveness, implementability, and cost to arrive at the selection of the top three corrective action options for consideration.

7.1 Identification of Potential Corrective Action Options

7.1.1 Corrective Action Objectives

According to the National Oil and Hazardous Substances Pollution Contingency Plan (NCP) the primary objectives should be:

- Select remedies that are protective of human health and the environment.
- Select remedies that maintain protection over time.
- Select remedies that minimize untreated wastes.
- Remedies that employ treatment must be given preference.
- Treatment must be appropriate for contaminants that comprise the principal threat at the site.
- Engineering controls are only appropriate for low-level threats when treatment is impractical.
- Institutional controls are to be used solely for mitigation of short-term impacts.
- Institutional controls can be used to supplement engineering controls for long-term waste management.
- Innovative technologies are only to be considered when there is significant reason to believe that they will work "as well" as other proven technologies.
- Groundwater should be returned to its beneficial use within a reasonable time frame.

Another objective to consider is that offsite transport and disposal is a least favored option.

7.1.2 General Response Actions

General Response Actions (GRAs) represent the universe of technologies that have the potential to provide for or contribute to contaminant remediation. GRAs include no action/institutional actions, containment actions, removal/extraction actions, collection/control actions, treatment actions, and storage/disposal/discharge actions.

7.1.2.1 No Action/Institutional Actions

This response involves no action being taken to implement remedial technologies to reduce the hazard potential to human or ecological receptors. If no action is taken, the contaminants may eventually flush to nearby creeks and streams. Natural biodegradation, dilution, or volatilization could also take place. Because available data are limited, it is not possible to accurately predict how long these natural processes would take; therefore, the potential impact on human health and the environment cannot be assessed. Although insufficient data exist, over time the area impacted by contamination will continue to increase, but the effective concentration of the contaminants will be reduced through dilution. Since BTX is the main contaminant present, volatilization will have a significant effect on contaminant reduction. Since this response does not meet the corrective action objective, the no action option will not be considered further.

The use of institutional actions as a means to protect human health and the environment when implemented with other remedial actions may also be considered. Institutional actions could involve the use of access restrictions through deed restrictions, physical barriers, and security personnel. Other actions may involve developing an alternate water supply at the remediation sites that have contaminated groundwater. Institutional actions may also include environmental monitoring of air, surface water, groundwater, soil, sediments, etc. to ensure that contaminants are not migrating offsite where they could impact public health and environmental receptors.

7.1.2.2 Containment Actions

Containment actions may include capping areas containing contaminated soil, or using subsurface barriers to minimize the movement of contaminated groundwater. Capping could be used to minimize the transport of contaminated surface material to the atmosphere or the infiltration/percolation of surface water/groundwater through the contaminated soil matrix.

Subsurface barriers, either vertical or horizontal, can be used to minimize the transport of contaminants through the groundwater, soil, or sediments by infiltration or percolation.

7.1.2.3 Removal/Extraction Actions

The removal/extraction of the source of contaminated materials is achieved through soil/sediment excavation, bulk removal, injection/extraction techniques, demolition, or decontamination. Earth moving equipment can be used to excavate and exhume contaminated materials. Equipment can also be used to remove contaminated solid waste (drums and debris) from the grounds, structures, or waste piles. Wrecking equipment can be used to demolish structures and buildings overlying contaminated areas. Decontamination techniques can be used to decontaminate structures and solid surfaces. Extraction wells can be used to extract contaminated groundwater. Injection wells can be used to enhance the groundwater flow to extraction wells.

7.1.2.4 Collection/Control Actions

Collection/control can involve surface controls, collection and storage systems, emission control, vapor collection, and sediment control. These remedial actions can reduce the mobility of the contaminants and can be used to retain contaminated waste streams for subsequent treatment. Collection/control technologies could also be used to collect and control the residuals from the treatment of contaminated wastes.

7.1.2.5 Treatment Actions

Treatment involves the use of in situ or ex situ physical, chemical, biological, thermal, and dewatering technologies to reduce or eliminate the toxicity, volume, or mobility of the contaminants of concern.

Physical technologies can be generally used on wastes to reduce the volume of the contaminated materials by physical separation techniques and segregation. Stabilization and solidification techniques can be used in situ or following removal. Soil washing, air stripping, soil flushing, and adsorption/absorption are all physical processes.

Chemical technologies can be used to alter the chemical structure of the waste constituents to produce a waste residue that is less hazardous than the original waste. Chemical processes can also separate the contaminants from solid waste media through chemical extraction or leaching

techniques to reduce the volume or mobility of the contaminants. Chemical solidification, stabilization, and fixation techniques can be used to form a bond with the waste material, resulting in solids or stable materials that are resistant to the leaching of contaminants.

Biological technologies are used mainly for degradation of organically contaminated media. Several well-developed biological technologies exist for the treatment of aqueous waste streams contaminated at various levels with nonhalogenated organics and some halogenated organics. Contaminated sludges and soils can be treated by solid-phase and slurry-phase processes. These processes have been developed and used to treat a wide range of contaminants such as pesticides, diesel fuel, gasoline, fuel oil, creosote, pentachlorophenol, and some halogenated volatile organics.

Thermal treatment is a term associated with the use of elevated temperatures as the principal means of destroying, detoxifying, or physically stabilizing hazardous wastes. There are several thermal processing options such as incineration, infrared heating, wet air oxidation, pyrolysis, thermal desorption, and vitrification.

In Situ treatment involves various physical, chemical, biological, and thermal techniques to treat source contamination in place.

Dewatering techniques are mainly used on aqueous waste streams as a means to separate non-soluble contaminants.

7.1.2.6 Storage/Disposal/Discharge Actions

Temporary *storage* could reduce the mobility of the waste materials by isolating the contaminants from further transport and minimizing the potential for short-term exposure of the population and impacts to the environment. Temporary storage action would involve the use of an engineered structure, existing or newly constructed, to contain the waste materials. This option is only considered as an interim action until a permanent treatment and/or disposal methodology is implemented.

Disposal involves the permanent and final placement of the waste materials in a manner that protects human health and the environment. Untreated waste can be disposed of onsite in an engineered facility, offsite in an approved and licensed disposal facility, or in a regulated landfill.

Treated waste and concentrated wastes from treatment processes can be disposed in a similar manner.

Discharge involves the permanent and final placement of an aqueous waste stream in a manner that protects human health and the environment. Treated liquid waste can be discharged onsite to surface waters or injected into the ground. Offsite discharge can involve deep well injection, piping to a river/stream offsite, or discharge to the local Publicly Owned Treatment Works (POTW).

7.1.3 Initial Screening Criteria

The purpose of the initial screening process is to review and evaluate technologies and eliminate those inappropriate for site contaminants or site conditions at the Building 9201-1 Site. This screening process is designed to eliminate actions that do not provide a permanent means to prevent or minimize the release of contaminants, or that cannot be implemented as a result of conditions at the site. The technologies and options reviewed as part of the screening process represent those currently being employed on a regular and successful basis at other petroleum-contaminated sites. Technologies that are untested or in the early stages of development are not reviewed.

The criteria used in the initial screening process are as follows:

- the applicability of a general response action to the affected media,
- the compatibility of a remedial technology with the contaminant of concern,
- the applicability of a remedial technology to the contaminant fate,
- the long-term durability of a process option,
- the volume and character of wastes generated by a process option,
- the management of a process option in a reasonable period of time, and
- the control of a process option over potential unknown or outside influences.

7.1.4 Initial Screening of Technologies and Process Options

7.1.4.1 Soil Remediation

The hierarchy of responses, technologies, and options for the initial screening of the contaminants in soil is shown in Table 7-1. This table is formatted (as a flow chart) so that, for each general response action, different remedial technology types and various process options are presented. A



Table 7-1. Initial Screening of Technologies and Process Options for the Building 9201-1 Soil Remediation

| Soil General Response Action | Remedial Technology | Process Options | Description | Screening Comments |
|--|--|--|---|--|
| <div style="border: 1px solid black; padding: 5px; width: fit-content;">No-Action/ Institutional Actions</div> <div style="background-color: black; width: 80px; height: 20px; margin-left: 10px;"></div> | <div style="background-color: black; width: 80px; height: 40px; margin-left: 10px;"></div> | <div style="background-color: black; width: 80px; height: 40px; margin-left: 10px;"></div> <div style="background-color: black; width: 80px; height: 40px; margin-left: 10px;"></div> | <p>Fences, signs surrounding sites.</p> <p>Deeds for property in the area of influence could include restriction on wells.</p> | <p>Not applicable: regulatory required remedial action necessary.</p> <p>Not applicable: regulatory required remedial action necessary.</p> |
| | <div style="border: 1px solid black; padding: 5px; width: fit-content;">Monitoring</div> | <div style="border: 1px solid black; padding: 5px; width: fit-content;">Soil Sampling</div> | <p>Ongoing monitoring of soil before, during, and after site remediation.</p> | <p>Potentially applicable.</p> |
| | <div style="background-color: black; width: 80px; height: 40px; margin-left: 10px;"></div> | <div style="background-color: black; width: 80px; height: 80px; margin-left: 10px;"></div> | <p>Various cap construction materials installed over contaminated areas.</p> | <p>Not applicable: remedial action would potentially prevent source material from continuing to contaminate groundwater; however, would not remediate present contaminated groundwater.</p> |
| | <div style="background-color: black; width: 80px; height: 40px; margin-left: 10px;"></div> | <div style="background-color: black; width: 80px; height: 80px; margin-left: 10px;"></div> | <p>Various methods may be used to construct vertical barriers to minimize or prevent migration of contaminants in soil to groundwater.</p> | <p>Not applicable: source movement has already reached groundwater.</p> |
| | <div style="background-color: black; width: 80px; height: 40px; margin-left: 10px;"></div> | <div style="background-color: black; width: 80px; height: 80px; margin-left: 10px;"></div> | <p>Various methods may be used to construct horizontal barriers below contaminated areas to minimize or prevent migration of contaminants in soil to groundwater.</p> | <p>Not applicable: source movement has already reached groundwater.</p> |

7-6

Indicates the technologies and processes eliminated from consideration.

Table 7-1. (continued)

| Soil General Response Action | Remedial Technology | Process Options | Description | Screening Comments |
|------------------------------|---|---|--|--|
| Removal/ Extraction | Excavation | Earth Moving Equipment | Conventional earth moving equipment such as bulldozers, hoes, loaders, etc. used to unearth soils. | Potentially applicable. |
| |  |  | Placement of arrays of soil gas extraction wells with subsequent pumping to encourage partitioning of volatile constituents into mobilized soil gas stream. Volatiles are removed from gas through condensation or activated carbon. | Not applicable: low permeability of site soils hinders process effectiveness. |
| Collection/ Control | Surface Controls | Grading, dikes, berms, etc. | Diversion systems for controlling surface water runoff and runoff. | Potentially applicable if soil excavation is required. |
| | |  | Compost material is stacked into elongated pile and aerated by turning (open) or by injecting air (static). Nutrients and microbes can also be added. | Not applicable: process requires the addition of highly biodegradable material (i.e., wood chips, chopped hay, etc.) to facilitate the biodegradation. The increase in volume of material to treat would make it more difficult to manage and control. |
| Treatment | Biological | Slurry-Phase Bioremediation | Soil is treated in a large mobile bioreactor where nutrients and biomass are added and mixed to an aqueous slurry. | Potentially applicable; but requires extensive residual treatment. |
| | | Solid-Phase Bioremediation | Soil is processed in an above ground treatment bed where nutrients and microbial inoculum are added. | Potentially applicable. |

7-7



Indicates the technologies and processes eliminated from consideration.

Table 7-1. (continued)





| Soil General Response Action | Remedial Technology | Process Options | Description | Screening Comments |
|------------------------------|--------------------------------|---|---|--|
| <p>Treatment (cont.)</p> | <p>Thermal</p> <p>Physical</p> | <p>Thermal Desorption</p> <p>Incineration</p> | <p>Refer to description under in situ treatment.</p> <p>Moderate temperature (200-600°F) vaporization using rotary drums or pug mill to separate VOCs and TPH from the soil media.</p> <p>High-temperature incineration (1400-3000 °F) using rotary kilns, multiple hearth furnaces, or fluidized beds to destroy all organic contaminants in the soil.</p> <p>Steam stripping coupled with simultaneous vacuuming and internal recycling to remove volatile gasoline products from soil.</p> <p>Solidification of excavated soil using various cements and silicate-based mixtures as solidifying agents. The resulting solids are very resistant to leaching.</p> | <p>Not applicable.</p> <p>Potentially applicable.</p> <p>Potentially applicable, but very energy intensive and can be cost intensive.</p> <p>Not applicable: low permeability of site soils hinders the process effectiveness.</p> <p>Not applicable: possibility of high organic content preventing waste solidification.</p> |

7-8



Indicates the technologies and processes eliminated from consideration.

Table 7-1. (continued)





| Soil General Response Action | Remedial Technology | Process Options | Description | Screening Comments |
|--|---|---|---|--|
| <p style="text-align: center;">Treatment (cont.)</p> | <p style="text-align: center;">Physical (cont.)</p> |  | <p>Physical microencapsulation of wastes in an organic binder or resin.</p> | <p>Not applicable for contaminants of concern.</p> |
| | |  | <p>Sealing of waste in asphalt bitument, paraffin, or polyethylene matrix.</p> | <p>Not applicable.</p> |
| | |  | <p>Mass transfer process in which dissolved volatile contaminants are transferred from soil to vapor phase (gas) by a physical means.</p> | <p>Not applicable: low permeability of site soils hinders process effectiveness.</p> |
| | | <p style="text-align: center;">Land Aeration</p> | <p>Spreading of soil on land surface to facilitate natural volatilization of VOCs.</p> | <p>Potentially applicable.</p> |
| | | <p style="text-align: center;">Soil Washing</p> | <p>Highly aggressive series of solid waste washing phases to leach contaminants.</p> | <p>Potentially applicable; the process produces a secondary waste stream that requires further treatment.</p> |
| | |  | <p>Soil is processed through mechanical separators to separate out or concentrate the contaminants.</p> | <p>Not applicable for the contaminants of concern, but potentially applicable in combination with other treatment processes.</p> |

7-9



Indicates the technologies and processes eliminated from consideration.

Table 7-1. (continued)



| Soil General Response Action | Remedial Technology | Process Options | Description | Screening Comments |
|------------------------------|---|---|---|---|
| <p>Treatment (cont.)</p> |  |     | <p>Solidify soil matrix through pressure injection grouting.</p> <p>Uses a system of electrodes to heat soil and volatilize trapped hydrocarbons so they may escape for treatment.</p> <p>Fusing of soils and contaminants into a glass-like form.</p> <p>Contaminants are washed from soils by injection of water in area of contamination and removed by pumping.</p> | <p>Not applicable: potential for cracking and high grout permeation coefficients in unconsolidated sediments.</p> <p>Not applicable: unproven technology.</p> <p>Not applicable: inability to verify performance and potential explosive danger. Not applicable for contaminants of concern.</p> <p>Not applicable: generates large amount of contaminated wastewater requiring additional treatment.</p> |

7-10

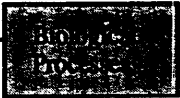
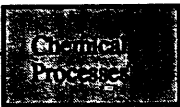

Indicates the technologies and processes eliminated from consideration.

Table 7-1. (continued)

| General Response Action | Remedial Technology | Process Options | Description | Screening Comments |
|--------------------------|---|--|--|--|
| <p>Treatment (cont.)</p> |  |    | <p>Add nutrients and possibly enzymes and microorganisms to enhance the ability of naturally occurring organisms to degrade the organic contaminants.</p> <p>Includes a variety of processes such as chemical oxidation, reduction, neutralization, precipitation, chelation, soil aeration, solvent flushing, etc. All processes involve a form of chemical addition to mitigate the contaminants in the soil.</p> <p>Stabilization/solidification of soils containing hazardous substances through the use of chemicals which form organic polymers with the wastes.</p> | <p>Not applicable: too difficult to measure performance of process.</p> <p>Not applicable: variety of chemical constituents requiring mitigation under uncontrolled conditions. Also creates unmanageable waste products.</p> <p>Not applicable: possibility that high organic content may prevent waste solidification.</p> |

7-11



Indicates the technologies and processes eliminated from consideration.

Table 7-1. (continued)

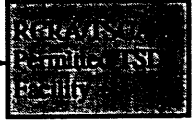
| Soil General Response Action | Remedial Technology | Process Options | Description | Screening Comments |
|------------------------------|--|---|--|--|
| <p>Disposal</p> | <p>Onsite Disposal</p> | <p>Controlled Landfill</p> | <p>Transport treated and/or untreated soils to onsite sanitary landfill for disposal.</p> | <p>Potentially applicable if contaminants are within acceptance criteria.</p> |
| | | <p>Backfill in Excavated Areas</p> | <p>Return treated soil to site excavation for use as backfill material.</p> | <p>Potentially applicable depending on use of onsite treatment process.</p> |
| | | <p>Uncontrolled Disposal</p> | <p>Onsite disposal of fully remediated or clean soils without restrictions.</p> | <p>Potentially applicable.</p> |
| | <p>Offsite Disposal</p> | <p>Controlled Landfill</p> | <p>Transport untreated soils to offsite controlled landfill for disposal.</p> | <p>Potentially applicable if contaminants are within acceptance criteria.</p> |
| | | <p>Uncontrolled Disposal</p> | <p>Transport fully remediated or clean soils to an offsite location without restrictions.</p> | <p>Potentially applicable.</p> |
| |  <p>Onsite Treatment/Disposal</p> |  <p>RCRA/TSCA permitted TSD facility</p> | <p>Involves transportation of contaminated soil to offsite RCRA/TSCA permitted TSD facility for treatment such as solidification, incineration, etc.</p> | <p>Not applicable: only applicable to hazardous waste generated by onsite treatment.</p> |

7-12



Indicates the technologies and processes eliminated from consideration.

brief description of each option is provided along with comments concerning elimination or selection for subsequent evaluation. The screening of remedial technologies is based on the characterization of contaminants identified at a given site. In the case of the Building 9201-1 Site, remedial technologies were evaluated based on their abilities to remediate soil materials primarily contaminated by BTX.

No Action/Institutional Actions

The remedial technologies screened for institutional actions included access restrictions and monitoring. Access restrictions include site security and deed restrictions. The only process option included within monitoring is soil sampling.

Site security involves the use of fences, berms, and signs surrounding the site to help prevent unauthorized access to the site. Security personnel can be used for controlling authorized access to the site. However, this process alone does not remedy the contaminant and, since site security is already in place at this location of the Y-12 Plant, this process option is not applicable.

Deed restrictions can be applied for the properties in the area of influence to require permits for digging, building, or any activity that can disturb the soils. However, this process alone does not remedy the contaminant, and since the contamination is confined to DOE-owned property, this process option is not applicable.

Monitoring of soils involves taking confirmatory samples in the area before and after remediation. This process option is required by TDEC; therefore, it is applicable.

Containment Actions

The remedial technologies screened for containment actions included capping, vertical barriers, and horizontal barriers. Capping includes clay, asphalt, concrete, geosynthetic, and multilayered materials. Vertical barriers include slurry walls, grout curtains, sheet piles, and vibrating beams. Horizontal barriers include grout injection, block displacement, liners, and ground freezing.

Various methods may be used to construct caps to minimize or prevent migration of contaminants within the soil to the groundwater. However, the petroleum contaminant has already infiltrated down to the water table, and capping does not reduce or eliminate the movement of previously contaminated groundwater; therefore, these process options are not applicable.

Various methods may be used to construct vertical and horizontal barriers to minimize or prevent migration of contaminants from within the soil to the groundwater. However, the contaminant has already reached the groundwater; therefore, these process options are not applicable.

Removal/Extraction Actions

The remedial technologies screened for removal/extraction actions included soil excavation and enhanced removal.

Excavation of soil can be conducted using conventional earth moving equipment such as bulldozers, backhoes, loaders, etc. to remove the soil for treatment and/or disposal. This process option is a common practice and is potentially applicable if ex situ treatment/disposal or direct disposal corrective actions are chosen.

The enhanced removal technique of vapor/vacuum extraction uses a series of injection/extraction wells to remove soil vapors so that contaminants can be separated and treated. Since this process extracts primarily VOCs in the soil vapors, this process is considered potentially applicable for the contaminants of concern; however, due to the low permeability of the soils, which can hinder the process effectiveness, this process is not applicable for the contaminant fate.

Collection/Control Actions

The remedial technologies screened for collection/control actions only included surface controls. Surface controls involve diversion systems such as grading, dikes, and berms for controlling surface water runoff and runoff. Surface water is not a medium of interest; however, surface control techniques would have to be implemented for soil excavation and certain site preparation needs. Therefore, this process option is retained for further consideration in combination with excavation.

Treatment Actions

The initial screening for treatment actions included biological, chemical, thermal, physical, and in situ remedial technologies.

Biological process options screened involved windrow composting, slurry-phase biodegradation, and solid-phase biodegradation. These processes have been demonstrated effective for treating soil contaminated with petroleum products.

Windrow composting involves adding highly biodegradable material, such as wood chips and chopped hay, to the excavated soil and stacking the compost material into elongated piles. Open windrows are aerated by turning and static windrows are aerated by injecting air through piping placed in the piles. This process option was considered not applicable because the volume of material at the soil treatment site would potentially be increased and become more difficult to manage and control.

Slurry-phase bioremediation involves mixing the soil into an aqueous slurry inside a mobile bioreactor where nutrients and biomass are added to degrade the contaminant. This process option is considered technically feasible and potentially applicable; however, the process generates additional volumes of waste and the process could involve extensive residual treatment.

Solid-phase bioremediation involves placing the contaminated soil in an aboveground, lined bed where nutrients and microbial inocula are added to facilitate the biodegradation process. This process option is considered technically feasible; therefore, it is potentially applicable.

Chemical process options can include a variety of processes such as chemical oxidation, reduction, neutralization, precipitation, chelation, solvent flushing, and others. All processes involve the addition of chemicals to mitigate the contaminants in the soil. All the chemical process options were considered not applicable because of the variety of chemical constituent residuals requiring further treatment under uncontrolled conditions and because these processes create additional waste which makes them more difficult to manage.

Thermal process options screened included low-temperature thermal desorption and incineration. These processes have been demonstrated effective for treating petroleum contaminated soils.

Low-temperature thermal desorption (LTTD) is a process that uses moderate heat (200-600°F) to vaporize organic contaminants in soil. LTTD systems are physical separation processes and are not designed to destroy the organic contaminants. This process option is considered technically feasible; therefore, it is potentially applicable.

High-temperature incineration (HTI) is a process that uses high temperatures (1,400-3,000°F) in devices such as rotary kilns, multiple hearth furnaces, or fluidized beds to destroy all organic contaminants in the soil. This process option is very energy intensive and can be cost intensive; however, it is considered technically feasible; therefore, it is potentially applicable.

Physical process options screened included steam stripping/vacuum extraction, cement solidification, surface micro-encapsulation, thermoplastic solidification, air sparging, land aeration, soil washing, and soil screening.

Steam stripping/vacuum extraction involves steam stripping coupled with simultaneous vacuuming and internal recycling to remove volatile gasoline products from soil. Volatile organic compounds are the primary contaminant of concern in soils; however, this process is considered not applicable due to the low permeability of the site soils, which hinders the process effectiveness.

Cement solidification, surface microencapsulation, and thermoplastic solidification involve the solidification or sealing of excavated soil using various cements, resin, organic binders, asphalt, and silicate-based mixtures as solidifying agents. The resulting solids are very resistant to leaching. Since these processes involve an increase in the volume of waste and are possibly influenced by the organic contents which may prevent complete solidification, these process options are considered not applicable for the contaminants of concern; therefore, they are considered not applicable.

Air sparging is a mass transfer process in which dissolved VOCs are transferred from soil to vapor phase (gas) by physical means. Although VOCs are the primary contaminants of concern, the low permeability of site soils hinders the process effectiveness; thus, this process is not applicable.

Land aeration involves the spreading of soil on land surface to facilitate natural volatilization of VOCs. Since VOCs are the primary contaminants of concern, this process option is considered potentially applicable.

Soil washing involves a highly aggressive series of solid waste washing phases to leach contaminants. This process option is potentially applicable; however, the residual waste stream may require additional treatment.

Soil screening involves processing soil through mechanical size separators to separate out or concentrate contaminants associated with a particular particle size. There is no evidence that

petroleum contamination adheres to any particular particle size, and the contaminated soils at the Building 9201-1 Site are fairly uniformly distributed clay particles; therefore, this process option is not considered applicable. However, mechanical screening may be used as a pretreatment step for other processes.

In situ process options screened included grouting, radio frequency heating, vitrification, soil flushing, biological processes, and chemical processes. All of these process options were considered not applicable, primarily because of the contaminant of concern and the generation of additional waste streams.

Disposal

Disposal techniques screened included onsite disposal, offsite disposal, and offsite treatment/disposal. Onsite disposal process options screened included controlled landfill, backfill in excavated areas, and uncontrolled disposal. Offsite disposal process options included controlled landfill and uncontrolled disposal. The only offsite treatment/disposal option screened involved a Resource Conservation and Recovery Act (RCRA)/Toxic Substances Control Act (TSCA) permitted treatment, storage, or disposal (TSD) facility.

Onsite or offsite disposal at a controlled landfill involves transport to a regulated landfill site of treated or untreated soils that meet the disposal acceptance criteria. Uncontrolled disposal at an onsite or offsite location involves the disposal of uncontaminated or fully remediated soils without restrictions. Each of these options is technically feasible, depending on the treatment process selected, if any, and the level of contamination; however, since a current moratorium exists for offsite transport of waste from the Y-12 Plant, the offsite controlled landfill is the least preferred method.

The onsite disposal process option of backfill in excavated areas involves returning treated soil to the site of excavation for use as backfill material. The time to treat the soil limits how fast the excavated site can be backfilled with the treated material. Since the excavation site would require immediate backfilling, this process option is dependent on the availability of an onsite treatment option running concurrently with excavation.

The offsite treatment/disposal process option of using a RCRA/TSCA permitted TSD facility involves transportation of contaminated soil to a permitted offsite TSD facility for treatment such as

solidification, incineration, etc. This process option is considered not applicable since the contaminants at the Building 9201-1 Site are not currently considered hazardous waste.

7.1.4.2 Groundwater Remediation

The hierarchy of responses, technologies, and process options for the initial screening of groundwater contamination is shown in Table 7-2. This table is formatted (as a flow chart) so that, for each general response action, different remedial technology types and various process options are presented. A brief description of each option is provided along with comments concerning elimination or selection for subsequent evaluation. The screening of remedial technologies is based on the characterization of contaminants identified at the site and the applicability of the process to groundwater remediation. In the case of the Building 9201-1 Site, remedial technologies were evaluated based on their abilities to remediate groundwater contaminated primarily by benzene.

No Action/Institutional Actions









The remedial technologies screened for institutional actions included access restrictions, alternate water supply, and monitoring. Access restrictions included site security and deed restrictions; alternate water supply included the use of river water and/or new well supply; monitoring included only groundwater monitoring.

Site security involves the use of fences, berms, and signs surrounding the site to help prevent unauthorized access to the site. Security personnel can be used for controlling authorized access to the site. However, this process alone does not remedy the groundwater contamination, and since site security is already in place at this location of the Y-12 Plant, this process option is not applicable.

Deed restrictions can be applied for the properties in the area of influence to require permits for digging wells or any activity that can disturb the aquifer in the area. The shallow aquifer at the Y-12 Plant is not being used as a drinking water supply; therefore, alternate water supplies are not required. However, these processes alone do not remedy the groundwater contamination, and since the contamination is confined to DOE-owned property, this process option is not applicable.

Monitoring of groundwater involves taking confirmatory samples in the area before, during, and after remediation. This process option is required by TDEC; therefore, it is applicable.





Table 7-2. Initial Screening of Technologies and Process Options for Building 9201-1 Site Groundwater Remediation

| Groundwater General Response Action | Remedial Technology | Process Options | Description | Screening Comments |
|---|---|--|---|--|
| <p>7-19</p> <p>No-Action/ Institutional Actions</p> |  |   | <p>Fences, signs surrounding site.</p> <p>Deeds for property in the area of influence could include restriction on wells.</p> | <p>Not applicable: regulatory required remedial action necessary.</p> <p>Not applicable: regulatory required remedial action necessary.</p> |
| |  |   | <p>Provide water supply from surface waters.</p> <p>New water supply wells.</p> | <p>Not applicable: wells are not used for water supply.</p> <p>Not applicable: wells are not used for water supply.</p> |
| | <p>Monitoring</p> | <p>Groundwater Monitoring</p> | <p>Ongoing monitoring of downgradient wells.</p> | <p>Potentially applicable.</p> |
| |  |   | <p>Various cap construction materials installed over contaminated areas.</p> | <p>Not applicable: capping could reduce or prevent the infiltration of contaminants in the soil to the groundwater; however, the groundwater is already contaminated and this remedial action would not reduce or prevent the migration of contaminated groundwater.</p> |



Indicates the technologies that are screened out.

Table 7-2. (continued)

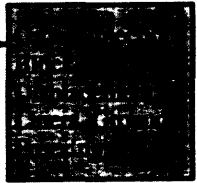
| Groundwater General Response Action | Remedial Technology | Process Options | Description | Screening Comments |
|---|--|--|---|---|
|  |   |   | <p>Various methods may be used to construct vertical barriers to minimize or prevent migration of contaminated groundwater.</p> <p>Various methods may be used to construct horizontal barriers to minimize or prevent migration of contaminated groundwater.</p> | <p>Not applicable: remedial action could potentially prevent or reduce the continuing migration of contaminated groundwater; however, would not remediate presently contaminated groundwater.</p> <p>Not applicable: remedial action could potentially prevent or reduce the continuing migration of contaminated groundwater; however, would not remediate presently contaminated groundwater.</p> |

7-20



Indicates the technologies that are screened out.





Table 7-2. (continued)

| Groundwater General Response Action | Remedial Technology | Process Options | Description | Screening Comments |
|-------------------------------------|-----------------------|-----------------------------|--|--|
| Removal/ Extraction | Pumping | Extraction Wells | Series of wells to extract contaminated groundwater. | Potentially applicable. |
| | | Extraction/ Injection Wells | Injection wells inject uncontaminated groundwater and direct flow towards extraction wells. | Potentially applicable. |
| Collection/ Control | Subsurface Drains | Interceptor Trenches | Perforated pipe in trenches backfilled with porous media to collect contaminated water. | Potentially applicable. |
| | | [Redacted] | Pumping wells are used in conjunction with the containment to control the migration of contaminated groundwater. | Not applicable: containment is not applicable. |
| | | [Redacted] | Degradation of organics using microorganisms in an aerobic environment. | Not applicable: organic concentration too low. |
| | | [Redacted] | Degradation of organics in an aerobic environment by microorganisms attached to media in a packed bed. | Not applicable: organic concentration too low. |
| Treatment | Biological* Treatment | [Redacted] | Aerobic degradation of organics by microorganisms attached to rotating media. | Not applicable: organic concentration too low. |
| | | [Redacted] | Biodegradation in an aerated surface pond. | Not applicable: organic concentration too low, requires large land area. |
| | | [Redacted] | Degradation of organics in an oxygen-free environment. | Not applicable: possibility of toxic levels of contaminants. |

* - May have to be combined with other treatment methods that remove inorganic chemicals.

 Indicates the technologies that are screened out.





Table 7-2. (continued)

| Groundwater General Response Action | Remedial Technology | Process Options | Description | Screening Comments |
|-------------------------------------|---------------------------------------|---|--|--|
| <p>Treatment (cont'd)</p> | <p>Biological* Treatment (cont'd)</p> |  | <p>Activated carbon plus biological degradation in an aerobic environment.</p> | <p>Not applicable: organic concentration too low.</p> |
| | |  | <p>Microorganisms used for degradation in a fluidized bed.</p> | <p>Not applicable: relatively new and unproven technology.</p> |
| | | <p>Slurry-Phase Bioremediation</p> | <p>Collected groundwater is mixed with contaminated soil and fed into a bioreactor on surface that biologically degrades contaminants in both media.</p> | <p>Potentially applicable.</p> |
| | <p>Chemical Treatment</p> |  | <p>Chemical equilibria altered to reduce the solubility of the contaminants; polymers added to promote flocculation of precipitated flocs for removal.</p> | <p>Not applicable: removal efficiency is low in dilute solutions, particularly for organics and lead.</p> |
| | | <p>Neutralization</p> | <p>pH adjusted for further treatment or discharge.</p> | <p>Potentially applicable in combination with additional treatment.</p> |
| | | <p>Oxidation/Reduction</p> | <p>Appropriate chemicals added to either raise or lower oxidation state of reactant.</p> | <p>Potentially applicable, but is usually a preliminary treatment step prior to biological or physical/chemical treatment. Requires constant reagent addition resulting in high O&M costs.</p> |
| | |  | <p>Chemical decomposition by hydrolytic reactions.</p> | <p>Not applicable: selective hydrolysis of certain compounds and generation of secondary wastes.</p> |

* - May have to be combined with other treatment methods that remove inorganic chemicals.

 Indicates the technologies that are screened out.

Table 7-2. (continued)



| Groundwater General Response Action | Remedial Technology | Process Options | Description | Screening Comments |
|-------------------------------------|------------------------------------|---|--|---|
| <p>Treatment (cont'd)</p> | <p>Chemical Treatment (cont'd)</p> |  | <p>Combination of ozone and ultraviolet oxidation of hazardous constituents resulting in contaminant breakdown.</p> | <p>Not applicable: generation of secondary wastes, selective oxidation of certain compounds, need for a continuous univalent oxygen supply.</p> |
| | |  | <p>Chlorine used as an oxidizing agent followed by dechlorination by reaction with a reducing agent.</p> | <p>Not technically feasible since it has very limited applicability and may not be suitable for all the organics present in the water.</p> |
| | |  | <p>Clarifier or sedimentation tanks used to promote settling and removal of precipitated flocs.</p> | <p>Not necessary if precipitation/coagulation/flocculation is not used.</p> |
| | <p>Physical Treatment</p> | <p>Filtration</p> | <p>Granular media used to filter suspended solids and colloids.</p> | <p>Potentially applicable; necessary to protect any processes from fouling, but does not treat the contaminants of concern.</p> |
| | | <p>Carbon Adsorption</p> | <p>Adsorption of contaminants by activated carbon by passing water through an activated carbon column.</p> | <p>Potentially applicable; however, produces a secondary waste stream.</p> |
| | |  | <p>Contaminated water is passed through a resin bed where ions are exchanged between resin and water; sorptive resins can be used sometimes where the removal mechanism is one of sorption rather than ion exchange.</p> | <p>Not applicable for contaminants of concern.</p> |

7-23



Indicates the technologies that are screened out.

Table 7-2. (continued)

| Groundwater General Response Action | Remedial Technology | Process Options | Description | Screening Comments |
|-------------------------------------|------------------------------------|--|---|--|
| <p>Treatment (cont'd)</p> | <p>Physical Treatment (cont'd)</p> | <p>Air Stripping</p> <p>Steam Stripping</p> <p>Distillation</p> <p> Dissolved Air Flotation</p> <p> Oil/Water Separation</p> <p>Tray Aeration</p> | <p>Large volumes of air mixed with water in a packed tower to promote partitioning of VOCs to air.</p> <p>Same removal process as air stripping but with steam as the removal medium. Appropriate for the more soluble volatile organic fraction in water.</p> <p>Groundwater constituents separated based on volatility differences.</p> <p>Minute air bubbles introduced by pressurization/depressurization means which rise to the surface carrying low density solids (particles) for collection.</p> <p>Floating oil in a settling tank is skimmed with an oil skimmer. Acids may be added to break oil/water emulsion and enhance process.</p> <p>Water flows across a baffled tray; air bubbles are blown through holes in the bottom of the tray to promote volatilization of contaminants.</p> | <p>Potentially applicable as a treatment method for the VOCs in the groundwater.</p> <p>Potentially applicable. Steam stripping costs will be substantially higher than most biological or other physical treatment methods for dissolved organics.</p> <p>Potentially applicable; substantially higher costs over other physical treatment methods.</p> <p>Not applicable: technology not amenable to characteristics of the contaminated media.</p> <p>Not applicable: ineffective with dissolved constituents.</p> <p>Potentially applicable.</p> |

7-24



Indicates the technologies that are screened out.

Table 7-2. (continued)

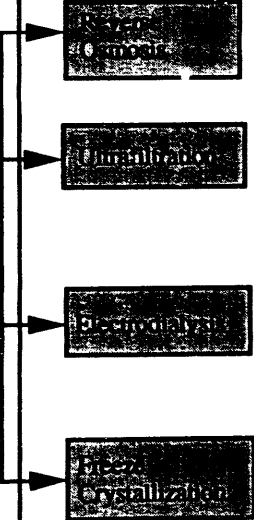
| Groundwater General Response Action | Remedial Technology | Process Options | Description | Screening Comments |
|-------------------------------------|------------------------------------|--|---|---|
| <p>Treatment (cont'd)</p> | <p>Physical Treatment (cont'd)</p> |  | <p>High pressure used to force water through a membrane leaving the contaminant behind.</p> <p>Similar membrane separation process as reverse osmosis, but can separate organics of a subcolloidal nature as well as colloidal and particulate matter.</p> <p>Another membrane separation process, the membrane is used for selective ion transport with the principal driving force being an electrical potential gradient.</p> <p>Process in which certain solutes crystallize out from a saturated solution when the solvent is cooled to freezing levels.</p> | <p>Not applicable: results in large volume of waste water that requires additional treatment.</p> <p>Not applicable to the contaminants found in groundwater at the site (does not reduce toxicity).</p> <p>Not applicable to the contaminants found in groundwater at the site (usually applicable to water containing dissolved salts).</p> <p>Not applicable to the contaminants in the groundwater at the site.</p> |

7-25



Indicates the technologies that are screened out.

Table 7-2. (continued)

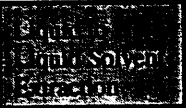
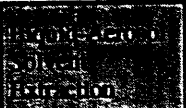

| Groundwater General Response Action | Remedial Technology | Process Options | Description | Screening Comments |
|-------------------------------------|------------------------------------|--|---|--|
| <p>Treatment (cont'd)</p> | <p>Physical Treatment (cont'd)</p> | <p>Thin-film Evaporation</p> <p></p> <p></p> | <p>Volatile constituents vaporized in a multi-stage evaporator.</p> <p>Dissolution of contaminants in a liquid solvent.</p> <p>Dissolution of contaminants in an aerosol or atomized solvent.</p> | <p>Potentially applicable; much higher costs than other physical treatment technologies.</p> <p>Not applicable: chemical requirements and generation of secondary wastes.</p> <p>Not applicable: same comments as for liquid to liquid solvent extraction.</p> |

7-26

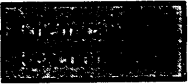

Indicates the technologies that are screened out.

Table 7-2. (continued)

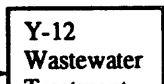
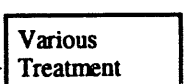

| Groundwater General Response Action | Remedial Technology | Process Options | Description | Screening Comments |
|---|---|--|---|--|
| <p>Treatment (Cont'd)</p> | <p>In Situ Treatment</p> | <p>Indigenous Bacteria</p> | <p>System of injection and extraction wells to introduce nutrients to stimulate natural biodegradation of contamination.</p> | <p>Potentially applicable.</p> |
| | | <p>Selective Bacteria</p> | <p>System of injection and extraction wells to introduce bacteria and nutrients to degrade contamination.</p> | <p>Potentially applicable.</p> |
| | |  | <p>System of injection and extraction wells to inject chemical reagents to treat contamination.</p> | <p>Not applicable: variety of chemical constituents; causes migration under uncontrolled conditions. Also creates unmanageable waste products.</p> |
| |  |  | <p>Trenches placed perpendicular to groundwater flow to treat groundwater as it passes by.</p> | <p>Not applicable: unproven technology.</p> |
| |  |  | <p>Basic purpose of all techniques is to reduce the volume and/or toxicity of organics in the wastewater by exposing it to high temperatures.</p> | <p>Not applicable: Ash produced may be considered hazardous due to metal content and produces a secondary waste stream.</p> |
| <p>Y-12 Wastewater Treatment Facilities</p> | <p>Various Treatment Technologies</p> | <p>Treatment through one or more of Y-12's wastewater treatment trains, using various physical, chemical, and biological treatment technologies.</p> | <p>Potentially applicable.</p> | |

7-27



Indicates the technologies that are screened out.

Table 7-2. (continued)

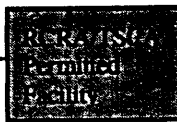
| Groundwater General Response Action | Remedial Technology | Process Options | Description | Screening Comments |
|-------------------------------------|--------------------------|---|--|--|
| <p>Disposal/ Discharge</p> | <p>Onsite Discharge</p> | <p>Y-12 Treatment Facility</p> | <p>Treated water discharged from Y-12 Plant industrial wastewater treatment system through NPDES permitted outfall.</p> | <p>Potentially applicable.</p> |
| | |  | <p>Extracted water discharged to deep well injection.</p> | <p>Not applicable: deep aquifer is not suitable for injection of contaminants.</p> |
| | | <p>Reinjection Wells</p> | <p>Extracted and treated water recharged back to the aquifer through a series of reinjection wells.</p> | <p>Potentially applicable; will require a TDEC permit.</p> |
| | | <p>Infiltration Gallery</p> | <p>Extracted and treated groundwater injected into shallow subsurface and distributed through gravel-fill area.</p> | <p>Potentially applicable; will require a TDEC permit.</p> |
| | | <p>Surface Water</p> | <p>Extracted and treated water discharged to surface water in the vicinity of the sites.</p> | <p>Potentially applicable; will require an NPDES permit.</p> |
| | <p>Offsite Discharge</p> |  | <p>Extracted water discharged to local publicly owned treatment works (POTW) for disposal.</p> | <p>Not applicable: extensive pretreatment will be required prior to discharge to POTW.</p> |
| | | <p>Streams Offsite</p> | <p>Extracted and treated water discharged to streams offsite.</p> | <p>Potentially applicable; will require an NPDES permit.</p> |
| | |  | <p>Contaminated groundwater or hazardous treatment by-products transported to an offsite RCRA TSD facility for treatment/disposal.</p> | <p>Not applicable: petroleum contaminated groundwater is not considered a hazardous waste.</p> |

7-28



Indicates the technologies that are screened out.

Containment Actions

The remedial technologies screened for containment actions included capping, vertical barriers, and horizontal barriers. Capping includes clay, asphalt, concrete, geosynthetic, and multilayered materials. Vertical barriers include slurry walls, grout curtains, sheet piles, and vibrating beams. Horizontal barriers include grout injection, block displacement, liners, and ground freezing.

Various methods may be used to construct caps to minimize or prevent migration of contaminants within the soil to the groundwater. However, the petroleum contaminant has already infiltrated to the water table, and capping does not reduce or eliminate the movement of groundwater; therefore, these process options are not applicable.

Various methods may be used to construct vertical and horizontal barriers to minimize or prevent migration of contaminants in the groundwater; however, they do not remediate the contaminants presently in the groundwater; therefore, these process options are not applicable.

Removal/Extraction Actions

The only remedial technology screened for removal/extraction actions involved pumping, which includes extraction wells and injection/extraction wells.

Extraction wells are placed in series and used to extract contaminated groundwater to the surface for treatment and/or disposal. Pump rates and pump frequencies (continuous or pulse) can be varied to obtain the desired results from the pumping system. Since any ex situ treatment process will require the extraction of the contaminated groundwater to the surface for treatment, this process option is potentially applicable.

In the extraction/injection process, a series of injection wells is used in conjunction with extraction wells to inject uncontaminated or treated groundwater, which can aid in directing and controlling the flow of contaminated groundwater towards the extraction wells. Since some treatment processes can treat contaminated groundwater in situ, the extraction/injection process can be used to introduce the reactants to the groundwater.

Collection/Control Actions

The remedial technology screened for collection/control actions included subsurface drains in the form of interceptor trenches for the collection and control of local hydraulic gradient to isolate contaminated groundwater.

Interceptor trenches can be used effectively to intercept and collect contaminated groundwater. Trenches are excavated below the water table where perforated pipes are placed in porous media that is backfilled in the trench. This process option costs more than extraction wells and increases exposure risks to workers; however, it is technically feasible and potentially applicable.

The spread or migration of the groundwater contaminant plume can be minimized by the combination of passive containment methods and active pumping wells to control the hydraulic gradient. All of the containment methods were determined to be not applicable; therefore, hydraulic gradient control must be considered not applicable.

Treatment Actions

The initial screening for treatment actions include biological, chemical, physical, in situ, and thermal remedial technologies. Onsite treatment at Y-12 wastewater treatment facilities is also examined.

Biological process options screened involved activated sludge reactors, trickling filters, fixed film systems (rotating biological contractors), aerated lagoons, enhanced treatment, and anaerobic digestion. These process options are primarily used for the treatment of municipal and industrial wastewater, which has high organic concentrations. The organic constituent of the petroleum contaminant in the groundwater at the Building 9201-1 Site is too low for these processes to be technically feasible; therefore, they are all screened as not applicable.

Fluidized bed reactors use microorganisms to degrade petroleum contaminated groundwater in a fluidized bed. This technology is relatively new and unproven; therefore, it is considered not applicable.

In the slurry-phase bioremediation process, collected groundwater is mixed with contaminated soil and fed into an ex situ bioreactor that biologically degrades the contaminants in both media. This process option is technically feasible, but can be very expensive.

Chemical process options can include a variety of processes such as precipitation/coagulation/flocculation, neutralization, oxidation/reduction, hydrolysis, ultraviolet (UV) oxidation, UV ozonation, and dechlorination. Precipitation/coagulation/flocculation and dechlorination are not applicable for the contaminants of concern. Hydrolysis and UV oxidation/ozonation are considered not applicable because of the generation of secondary wastes. Neutralization and oxidation/reduction are considered potentially applicable, but only as a preliminary treatment process in combination with further biological, physical, or chemical treatment.

Physical process options screened included sedimentation/clarification/gravity thickening, filtration, carbon adsorption, ion exchange/sorptive resins, air/steam stripping, tray aeration, distillation, dissolved air flotation, oil/water separation, reverse osmosis, ultrafiltration, electrodialysis, and freeze crystallization.

Sedimentation/clarification/gravity thickening uses clarifiers or sedimentation tanks to promote settling and removal of precipitated flocs; however, this process option is considered not applicable since precipitation/coagulation/flocculation was determined not applicable.

Filtration uses granular media to filter suspended solids and colloids. This process is necessary in most treatment processes to prevent fouling; thus, it is considered potentially applicable, but the process alone does not remove the contaminants of concern.

Carbon adsorption involves adsorption of contaminants by passing groundwater through an activated carbon column. This process is technically feasible for removing benzene and TPH from the groundwater media. The process does produce a secondary waste stream; however, it is easily managed. Thus, this process is potentially applicable.

Air stripping, steam stripping, distillation, and tray aeration are various methods of separating VOCs from the groundwater and all are retained for further consideration.

The dissolved air flotation process uses minute air bubbles to carry low density particles to the water surface for collection. This process is not applicable due to the non-particulate characteristic of the contaminated media (i.e., the contaminant is not in particle form); therefore, it is not applicable.

Oil/water separation and reverse osmosis processes were determined to be not applicable because these processes produce large volumes of waste water that require additional treatment.

Ultrafiltration, electro dialysis, and freeze crystallization were screened as not applicable for the contaminants of concern.

The thin-film evaporation process vaporizes volatile constituents in a multi-stage evaporator. This process is technically feasible and potentially applicable; however, the costs are much higher than for other physical processes.

The liquid-to-liquid and liquid-aerosol solvent extraction methods can dissolve petroleum contaminants. Both of these processes require the addition of chemicals, which generates a secondary waste stream requiring further treatment; therefore, they were screened as not applicable.

The *in situ* treatment technologies screened included indigenous and selective bacteria bioremediation, chemical reaction, and permeable treatment beds.

Indigenous bacteria in situ bioremediation uses a system of injection and extraction wells to introduce nutrients and oxygen to the groundwater to stimulate natural biodegradation of the petroleum contaminants. Selective bacteria in situ bioremediation is similar to the indigenous process except special strains of bacteria are also introduced to the groundwater. Both processes are technically feasible; therefore, they are potentially applicable.

A system of injection and extraction can also be used to inject chemical reagents into the groundwater to treat petroleum contamination. This process is similar to in situ biodegradation except chemical reactions rather than biological reactions occur. However, this process is considered not applicable because of creation of unmanageable waste products and potential uncontrolled migration of the chemical constituents.

Permeable treatment beds are constructed by excavating trenches perpendicular to the groundwater flow to intercept and treat the groundwater as it passes by. This process is relatively new and unproven; therefore, it is considered not applicable.

There are various *thermal treatment* processes that basically destroy or reduce the volume and/or toxicity of organics in the groundwater by exposing them to high temperatures. All thermal

treatment processes were screened as not applicable because of the potential for ash produced being considered a hazardous waste due to the concentration of heavy metals.

Treatment at *onsite wastewater treatment facilities* within the Waste Management organization use a combination of biological, chemical and physical treatment technologies. These multiple technologies are proven effective in the treatment of wastewater containing numerous contaminants.

Disposal/Discharge Actions

Disposal techniques screened included onsite discharge, offsite discharge, and offsite treatment/disposal. Groundwater may either be directly discharged with no treatment or discharged subsequently to one of the treatment actions previously discussed. Each of these techniques is discussed below.

Onsite discharge process options involve discharging groundwater through the Y-12 treatment facility, deep well injection, reinjection wells, infiltration galleries, or surface waters. Discharge from one of Y-12's wastewater treatment facilities is already permitted through the NPDES permit program. Additional permitting or adjustments of current permits would not be anticipated if this option is chosen. Onsite deep well injection was screened as not applicable because the deep aquifer in the region is not suitable for injection of contaminants. Onsite reinjection wells, infiltration galleries, and surface water discharge are potentially applicable, but will require an NPDES and/or TDEC permit.

Offsite discharge process options involve discharge to local offsite publicly owned treatment works (POTWs) or to streams offsite. Extracted water discharge to local POTWs was determined not applicable since extensive pretreatment would be required prior to transport offsite and discharge to POTWs. Extracted and treated water discharge to streams offsite is considered potentially applicable; however, an NPDES permit will be required.

The only *offsite treatment/disposal* process option screened was treatment/disposal at a RCRA or TSCA permitted TSD facility. This process option is considered not applicable since the groundwater contaminants at the Building 9201-1 Site are not currently considered hazardous waste.

7.1.5 Development of Corrective Action Options

7.1.5.1 Soil Remediation Corrective Action Options

This section describes the development of corrective action options from the process options that passed the initial screening evaluation for soil remediation. The remaining technology options for the soil general response actions are combined to form potential corrective action options for evaluation in Section 7.2.1. The soil general response actions retained for further evaluation include removal extraction, treatment, and disposal. Conventional excavation equipment would be used to remove contaminated soil for treatment and/or disposal. The treatment options include: thermal (incineration and thermal desorption), physical (steam stripping/vacuum extraction, air sparging, land aeration, and soil washing), and biological (slurry-phase and solid-phase bioremediation). Vapor/vacuum extraction techniques can be used to remove soil vapors where contaminants can be separated and treated from in situ soils. Disposal includes onsite and offsite options for treated soil and residuals from treatment. The remaining soil remediation technology options are briefly discussed below.

Removal/Extraction

These process options involve soil removal prior to treatment. The removal action for all potential corrective action options would involve the elimination of the source of contamination through soil excavation methods. Conventional excavation equipment would be used for the removal of the contaminated soil at the site. The Building 9201-1 Site is an active loading dock area and includes buildings and utilities in close proximity to the contaminated area. Smaller equipment or manual-excitation techniques may be implemented when required for this option. Certain institutional actions, such as soil monitoring and surface controls, are considered part of this technology option. Implementation of this action is the same for all eight of the treatment options. In addition, the asphalt pavement and gravel base will be excavated to obtain access to the contaminated soil and will require disposal at a suitable disposal facility.

Treatment (Thermal, Physical, and Biological)

The treatment options most applicable for corrective action are thermal desorption, incineration, aeration, soil washing, slurry-phase bioremediation, and solid-phase bioremediation. Each of these six process options requires that the contaminated soils be excavated from impacted areas before treatment. The thermal desorption method volatilizes the petroleum contaminants by heating

the excavated soils to temperatures between 200° and 600°F using a mobile unit. Incineration involves the thermal decomposition of organic constituents by cracking and oxidation reactions at very high temperatures, usually between 1,400° and 3,000°F. In land aeration the soil is spread and tilled to allow volatilization of the contamination through contact with the air. In the soil washing method, the excavated soils are washed repeatedly with water to remove contaminants. In the slurry-phase bioremediation process, the excavated soils are placed in a large mobile bioreactor for treatment. The solid phase bioremediation treatment method consists of excavating contaminated soils and transporting them to a prepared site for treatment with the introduction of nutrients and microorganisms. Although each of the active treatment methods (thermal desorption, incineration, steam stripping/vacuum extraction, air sparging, slurry-phase bioremediation, and soil washing) would remediate the contaminated soils, each would produce a waste product requiring disposal or secondary treatment prior to disposal.

Disposal (Onsite or Offsite)

Disposal includes the onsite and offsite options of controlled and uncontrolled disposal. For controlled disposal at a sanitary landfill, TDEC requires that the treated waste Toxicity Characteristic Leaching Procedure (TCLP) extracts for benzene and TPH not exceed 0.5 ppm and 10.0 ppm, respectively (TDEC, 1990). Landfill capacity limitations and potential institutional factors may limit the use of onsite disposal. The current moratorium against the offsite transportation of low-level waste from the Oak Ridge Reservation (ORR) restricts the use of offsite disposal. Due to the historical use of the Y-12 Plant, the potential for radiological contamination must be considered.

Controlled disposal involves the disposal of treated or untreated soil meeting the acceptance criteria at a sanitary landfill. The treated soil residuals from the incineration process (ash) are only considered suitable for controlled disposal as monofill material. Treated soils from the thermal desorption process are considered suitable for disposal at a sanitary landfill as cover material. After additional treatment, the concentrated waste fraction of the soil washing process can be considered for controlled disposal as cover material at a sanitary landfill.

Uncontrolled disposal involves using the treated material with suitable characteristics as clean fill or for direct land application. Soil treated by thermal desorption is only considered suitable as clean fill; however, if the soil is mixed with organics and/or fertilizers it can be made suitable for direct land application. The uncontaminated fraction of the soil washing process can also be considered

for uncontrolled disposal as fill material. Bioremediated and aerated soils are considered suitable for direct land application.

There is no confirmation that contaminated soils at the Building 9201-1 Site meet the definition of a RCRA hazardous waste. If some of the soils are determined to meet the definition of RCRA hazardous waste, the disposal options will be revised to include the RCRA regulatory requirements. As a contingency measure, soils found to be classified as RCRA hazardous waste will be segregated from non-hazardous soils and properly stored prior to final disposal (yet to be determined).

Potential Corrective Action Options for Soil Remediation

Contaminated soil excavation with direct disposal of the excavated soil is not considered a viable corrective action option and will not be considered further. However, excavation, treatment, and disposal combine into potential corrective action options. The potential corrective action options include:

- excavation, onsite thermal treatment (incineration or thermal desorption), and onsite/offsite controlled/uncontrolled disposal;
- excavation, onsite active physical treatment (soil washing), and onsite/offsite controlled landfill disposal;
- excavation, onsite passive physical treatment (land aeration), and onsite uncontrolled disposal; and
- excavation, onsite biological treatment (slurry-phase or solid-phase), and onsite uncontrolled disposal.

7.1.5.2 Groundwater Remediation Corrective Action Options

This section describes the development of corrective action options for groundwater remediation from the remaining technology options that passed the initial screening evaluation. The remaining technology options for the groundwater general remedial actions are combined to form potential corrective action options for evaluation in Section 7.2.2.2.

The groundwater general remedial actions retained for further evaluation include institutional (groundwater monitoring), removal/extraction (pumping), collection/control (subsurface drains), treatment, and disposal/discharge. Extraction using pumping methods includes the use of conventional extraction wells and injection/extraction wells for removal of contaminated groundwater. The institutional action of groundwater monitoring and the collection/control action of subsurface drains will be evaluated as part of the removal/extraction actions. The treatment options include: biological (slurry-phase bioremediation), chemical (neutralization and oxidation/reduction), physical (filtration, carbon adsorption, tray aeration, air stripping, steam stripping, distillation, and thin-film evaporation), onsite wastewater treatment facilities, and in situ (indigenous or selective bacteria). Disposal/discharge includes onsite and offsite discharge options for treated groundwater and residuals from groundwater treatment. These technology options are briefly discussed below.

Extraction/Removal (Pumping)

The extraction/removal action is required for all potential treatment options and would involve the removal of the contaminated groundwater by pumping methods. Conventional extraction wells would be used for the removal of the contaminated groundwater at the Building 9201-1 Site. Certain institutional actions, such as groundwater monitoring and collection/control actions, such as subsurface drains, are considered necessary for, or as an enhancement of, this technology option. Implementation of this action is the same for all four of the treatment technologies.

Treatment (Biological, Chemical, Physical, Onsite Wastewater Treatment Facilities, and In Situ)

The treatment technologies most applicable for corrective action involve biological, chemical, physical, onsite wastewater treatment facilities, and in situ process options. Each of these treatment technology types requires that the contaminated groundwater be extracted from impacted areas before treatment. The biological treatment method of slurry-phase bioremediation consists of extracting contaminated groundwater to the surface to be mixed with contaminated soil and placed in a bioreactor where nutrients and bacteria can be added and complete biodegradation can take place prior to disposal. The chemical methods of neutralization and oxidation/reduction are primarily pretreatment steps to adjust the pH of the contaminated groundwater. The physical treatment methods of filtration and carbon adsorption are primarily used as pretreatment and post-treatment steps, respectively. The other physical processes of air/steam stripping, tray aeration, distillation, and thin-film evaporation are methods used to separate the volatile fraction of the contaminants from water. Onsite treatment facilities use biological, chemical and physical

techniques for wastewater treatment, such as biological denitrification, biological oxidation, metals precipitation, coagulation, flocculation, clarification, filtration, and carbon adsorption. The in situ treatment methods using indigenous or selective bacteria involve extracting the groundwater to the surface to a bioreactor where nutrients and bacteria, if necessary, are added and then reintroduced to the groundwater.

Disposal/Discharge (Onsite or Offsite)

Discharge options involve the release of treated and residual groundwater waste at an onsite or offsite location. All processes will require NPDES and/or TDEC permits. Onsite discharge involves the use of reinjection wells, surface waters, infiltration galleries, or discharge through an onsite treatment facility. Offsite discharge involves piping treated groundwater to offsite streams for release; however, this process option is least favored due to the moratorium at ORR on the offsite transport of low-level contaminated waste.

Potential Corrective Action Options for Groundwater Remediation

Contaminated groundwater extraction with direct discharge is not considered a viable corrective action option and will not be considered further. However, a combination of extraction, treatment, and discharge are potential corrective action options. In addition, the chemical processes of neutralization and oxidation/reduction will only be considered in combination with biological and physical treatment processes. Therefore, the potential groundwater corrective action options include:

- extraction, onsite biological treatment, and onsite/offsite discharge;
- extraction, onsite physical treatment, and onsite/offsite discharge;
- extraction, onsite wastewater treatment facilities, and onsite discharge; and
- extraction/injection concurrent with in situ biological treatment.

7.2 Selection of Corrective Actions

This section presents an evaluation of the potential corrective action options based on their effectiveness, implementability, and cost. The options are evaluated in relation to the volumes of waste material and site-specific constraints.

7.2.1 Evaluation Criteria

7.2.1.1 Effectiveness

The identified corrective action options are evaluated to ensure that they effectively protect human health and the environment and satisfy the corrective action objectives identified for the media of interest. The ability and effectiveness of each technology option to reduce the contaminant concentrations or exposure levels or to sufficiently recover contaminated media for subsequent treatment are evaluated. The performance evaluation of a particular corrective action process involves a technical evaluation of the ability of the option to achieve the corrective action objectives.

The performance evaluation also necessitates determining how effective and reliable the technology option would be with respect to the contaminants and conditions at the site. Reliability is a major consideration in determining effectiveness due to the operation and maintenance (O&M) requirements of most technology options and the importance of protecting public health and the environment during remediation activities. The long-term management of residual contamination and/or untreated waste reduces the effectiveness of a technology; therefore, the duration of long-term management is evaluated as part of the technology's effectiveness.

7.2.1.2 Implementability

The implementability evaluation criteria include both technical and administrative considerations. Technical feasibility involves the availability and constructability of the technology option and the construction and implementation time frame. Implementation time and the period for beneficial results to be realized are critical to protecting public health and the environment.

The administrative considerations of implementability include: the ability to obtain the necessary approvals from regulatory agencies, availability of TSD facilities and associated capacities, and availability of necessary equipment and skilled workers to implement the technology.

7.2.1.3 Cost

Relative capital costs and O & M costs are used rather than detailed estimates. The complexity of the technology option will determine the detail required for the cost estimates. The cost analysis is based on engineering judgment, available vendor quotes, and costs reported from similar corrective actions implemented at other UST sites.

7.2.2 Evaluation of Corrective Actions

7.2.2.1 Soil Remediation Evaluation

The soil general response actions and remedial technologies evaluated in this section include: removal/extraction, thermal treatment, physical treatment, biological treatment, and disposal. The criteria described in section 7.2.1 were used to evaluate the remedial technologies within each of the soil general response actions remaining after the initial screening. The purpose of this evaluation is to identify the most effective, implementable, and cost-effective process options for attaining the Building 9201-1 Site corrective action objectives for soil remediation. Table 7-3 provides a summary of the evaluation of the remaining process options for contaminated soil at the Building 9201-1 Site.

Removal/Extraction

The removal action by soil excavation methods would effectively eliminate the source of contamination from the site but would generate a significant volume of waste requiring treatment and/or disposal. Short-term considerations of worker safety and environmental impacts due to dust and potential surface runoff would be considered by developing and implementing a Health and Safety Plan for the excavation activities (including dust control activities) and by including surface water runoff/runoff control in the corrective action design.

Conventional construction equipment would be used for excavating the contaminated soil at the site and, therefore, this action is readily implementable. The Building 9201-1 Site is adjacent to an active loading area in the exclusion zone of the Y-12 Plant and includes buildings and utilities in close proximity to the contaminated area requiring excavation. The limited available space may

Table 7-3. Evaluation of the Selected Process Options for Soil Remediation at the Building 9201-1 Site

| Soil General Response Action | Remedial Technology | Process Options | Effectiveness | Implementability | Cost |
|------------------------------|---------------------|-----------------------------|---|--|--------------------------------|
| Removal | Excavation | Soil Excavation Equipment | Moderate to high; would remove source but would create large waste volume requiring treatment/disposal. | Readily implementable. | Moderate; no O&M. |
| Treatment | Thermal Treatment | Incineration | Moderate to high; would destroy source but creates waste volume requiring disposal. | Implementable, but requires treatability study to define specific operational requirements. | High; no O&M. |
| | | Thermal Desorption | Moderate to high; would destroy source of contaminant. | Readily implementable, but requires treatability study to define specific operational requirements. | Moderate to high; no O&M. |
| | Physical | Soil Washing | Low to moderate; would remove source but may generate large quantities of wastewater requiring disposal. Addition of surfactants will be required for removal of contaminants. | Implementable, but requires treatability study to define specific operational requirements and chemical additions needed. | Moderate; moderate O&M. |
| | | Land Aeration | Moderate to high; volatiles are aerated into environment, eliminating source. | Readily implementable. | Low; moderate O&M. |
| | Biological | Slurry-Phase Bioremediation | Moderate to high; would remove source by complete degradation of hydrocarbon contaminants to CO ₂ and H ₂ O, but may require additional treatment of residual wastewater. | Implementable; requires treatability study to define operational requirements, i.e., addition of nutrients, oxygen source, pH adjustment, microbes, etc. | Moderate; low O&M. |
| | | Solid Phase Bioremediation | Moderate; biodegradation breaks down hydrocarbon contaminants to CO ₂ and H ₂ O, eliminating source. | Mostly implementable; requires extensive treatability testing to determine operational requirements, i.e., addition of nutrients, oxygen source, pH adjustment, microbes, etc. | Low; very low to moderate O&M. |

7-41

Table 7-3. (continued)

| Soil General Response Action | Remedial Technology | Process Options | Effectiveness | Implementability | Cost |
|------------------------------|--|--|--|--|---|
| <p>Disposal</p> | <p>Onsite disposal</p> <p>Offsite disposal</p> | <p>Controlled landfill</p> <p>Backfill in Excavated Areas</p> <p>Uncontrolled</p> <p>Controlled landfill</p> <p>Uncontrolled</p> | <p>High; would be used for disposal of untreated soil and residuals from treatment; limited institutional factors.</p> <p>High; would be used for disposal of untreated soil and residuals from treatment; limited institutional factors.</p> <p>High; would be used for disposal of non-hazardous treatment residuals; limited institutional factors.</p> <p>High; would be used for disposal of untreated soil and residuals from treatment; significant institutional factors.</p> <p>High; would be used for disposal of non-hazardous treatment residuals; significant institutional factors.</p> | <p>Readily implementable.</p> <p>Readily implementable.</p> <p>Readily implementable.</p> <p>Readily implementable, if moratorium on offsite shipments is no longer in effect.</p> <p>Readily implementable.</p> | <p>Moderate to high.</p> <p>Low.</p> <p>Low to moderate.</p> <p>High.</p> <p>Moderate to high</p> |

7-42

impact the use of larger conventional excavation equipment in some areas and, therefore, may slow down the removal action. Excavation is required for all of the remaining treatment process options. The capital costs for the excavation action are moderate with no O&M costs.

Thermal Treatment (Incineration)

Incineration involves the thermal destruction of organic constituents by cracking and oxidation reactions at high temperature. The organic components of the contaminated soil are converted into carbon dioxide and water. The inorganic constituents of the contaminated soil would not be destroyed by incineration and would exit the incinerator as either bottom ash from the combustion chamber or fly ash particulates from the baghouse or scrubber. The bottom ash waste is usually stabilized with water, for workability, and landfill disposed. Air pollution control systems are used to remove volatile organics and other hazardous air pollutants from the effluent gas stream. The waste stream generated by the air pollution control system may require an additional treatment operation prior to disposal.

A major consideration in evaluating the effectiveness of incineration is based on the thermal conductivity and heating value of the waste. The inability of the contaminated soil to transfer heat and maintain combustion requires the addition of an auxiliary fuel in order to obtain the necessary performance standards for destruction of organics. High concentrations of water in the contaminated soil would also detract from the operational effectiveness of incineration.

The treated soil would be considered for disposal as monofill material at a landfill. This option provides for the removal of the contaminant source and, therefore, provides for the overall protection of human health and the environment. The performance of this particular corrective action process has been proven successful at a number of similar sites and is considered to be reliable overall.

The time frame for completion of this action is considered acceptable because of the limited volume of contaminated soil to be removed and the proven performance of this treatment process. Incineration has been proven effective and reliable at hazardous waste sites and similar UST sites.

Incineration of petroleum contaminated soils has not been previously implemented at ORR. Administrative and regulatory considerations may impact the implementability of this option due to potential permit requirements and/or environmental impact evaluations. There are numerous vendors with the necessary equipment and skilled workers to implement this technology. There

would be no long-term management of residual contamination and/or untreated waste due to the complete removal of the contaminants. Capital costs would be high with negligible O&M.

Thermal Treatment (Thermal Desorption)

Thermal desorption involves the separation of organic contaminants by heating soils from 200° to 600° F. This option would physically separate the VOCs from the contaminated soil. In this process, dust particles and VOCs exit the heating unit as exhaust gas. The dust particles are collected in a baghouse or scrubber. The VOCs are incinerated in an afterburner or adsorbed by an activated carbon filter. The soil would be considered as fill material or as cover material for disposal at a landfill. This option provides for the removal of the contaminant source and, therefore, provides for the overall protection of human health and the environment.

The time frame for completion of this action is considered acceptable because of the limited volume of contaminated soil to be removed and the proven performance of this treatment process. Thermal desorption has been proven effective and reliable at similar UST sites. This technology has not been previously implemented at ORR.

Potential permit requirements and/or environmental impact evaluations must be considered in implementation of this technology. There are numerous vendors available with the necessary equipment and skilled workers to implement this technology. There would be no long-term management of residual contamination and/or untreated waste due to the removal of the contaminants and subsequent disposal. Capital costs would be moderate to high with negligible O&M.

Active Physical Treatment (Soil Washing)

Soil washing involves the repeated washing of contaminated soils with water to remove the contaminants of concern. Certain surfactants or chemical additions may be required to facilitate adequate removal of the petroleum hydrocarbons. Large volumes of wastewater would be generated and would require additional onsite equipment for treatment prior to disposal or discharge.

The soil washing process would separate the contaminants and provide for a reduction in contaminated soil volume. Additional treatment operations would be required to degrade or stabilize the concentrated contaminated materials. In addition, soil washing is difficult to implement

effectively in clayey soils, which are a major component of the soil matrix at the Building 9201-1 Site. This technology has not been previously implemented at ORR.

Administrative and regulatory considerations may impact the implementability of this option due to potential permit requirements and/or environmental impact evaluations. There would be long-term management of residual contamination from the treatment process. There are vendors available with the necessary equipment and skilled workers to implement this technology. Soil washing has been proven effective and reliable for separation of petroleum hydrocarbons at similar UST sites. Capital costs would be moderate with moderate O&M.

Passive Physical Treatment (Land Aeration)

Physical treatment of the excavated contaminated soil could involve land aeration of the soil to drive off volatile organics. This process is particularly cost effective for remediating sites contaminated by gasoline. The contaminated soil is first mechanically screened to remove large stones and debris and create voids in the material. The soil is then spread over a synthetic liner in a treatment area in a layer as thin as 1 ft. Periodic tilling maintains air contact with the contaminated soil and promotes volatilization of the BTX contamination. A synthetic cover is pulled into place during precipitation events to limit water infiltration.

Land aeration allows the BTX contamination to escape the soil by the natural process of volatilization until the contamination is within regulatory limits. This option would satisfy the corrective action objectives identified for the soil. This technology has not previously been implemented at ORR.

Administrative and regulatory considerations may impact the implementability of this option due to potential air permit requirements. There would be no long term management of residual contamination from the treatment process due to the volatilization of the contaminants of concern. The technology would be performed by plant employees familiar with conventional farming equipment. Volatilization will begin to occur as soon as the soil is excavated and is very effective and reliable for removing BTX contamination. Capital cost would be low with moderate O & M.

Biological Treatment (Slurry-Phase Bioremediation)

Solid-phase bioremediation involves the treatment of contaminated soil in a large mobile bioreactor. The first step of this system is to physically separate stones and rubble from the waste and mix the

remainder with water to create a slurry. Contaminated groundwater may be used as a source for the mix water. The slurry is mechanically agitated in a reactor vessel to keep the solids suspended. Inorganic and organic nutrients, oxygen, and chemicals for pH control may be added to maintain optimum environmental conditions. Microorganisms may be added initially to seed or continuously to maintain the correct biomass. Once the biodegradation is complete, the treated slurry is dewatered. The residual water may require further treatment. Biological treatment removes the source of contamination by biological decomposition of the petroleum contaminants below action levels. This option would satisfy the corrective action objectives identified for the soil. This technology has not been previously implemented at ORR, but has been proven effective at other petroleum contaminated sites.

Administrative and regulatory considerations may impact the implementability of this option due to potential permit requirements and/or environmental impact evaluations. There would be no long-term management of residual contamination from the treatment process due to the complete decomposition of the contaminants of concern. There are vendors available with the necessary equipment and skilled workers to implement this technology. Capital costs would be moderate with low O&M.

Biological Treatment (Solid Phase Bioremediation)

Biological treatment of the excavated contaminated soil would involve the aerobic degradation by a solid phase bioremediation process. A bioaugmentation (addition of microorganisms) biological treatment process involves excavating the contaminated soil and transporting it to a designated location for biological treatment. The soils would be treated in biological cells constructed for the volume of soil excavated. Aeration and nutrient addition systems would supply nutrients, oxygen, water, and microbes as needed during the operation of the process.

Biological treatment removes the source of contamination by biological decomposition of the petroleum contaminants below action levels. This option would satisfy the corrective action objectives identified for the soil. This technology has not been previously implemented at ORR.

Administrative and regulatory considerations may impact the implementability of this option due to potential permit requirements and/or environmental impact evaluations. There would be no long-term management of residual contamination from the treatment process due to the decomposition of the contaminants of concern. There are vendors available with the necessary equipment and skilled workers to implement this technology. Bioremediation has been proven effective and reliable for

destruction of petroleum hydrocarbons at similar sites. Capital costs would be low with very low to moderate O&M.

Disposal (Onsite/Offsite)

Disposal actions involve the preparation and transport of treated (treatment residual) and untreated waste. For disposal at a controlled landfill, TDEC requires that the treated waste TCLP extract for benzene and TPH not exceed 0.5 ppm and 10.0 ppm, respectively. Untreated waste is excavated soil that will not be treated. Treated soils with suitable physical characteristics are considered for uncontrolled disposal by direct land application or as fill material. These waste materials would not meet the definition of a RCRA hazardous waste. If the treated or untreated wastes are determined by the waste characterization study to be classified as RCRA hazardous waste, the disposal options will include disposal per RCRA regulatory requirements. The high effectiveness of all disposal options ensures the protection of human health and the environment.

Options for disposal include onsite and offsite options for treated and untreated soils. Onsite options for disposal are less costly than those for offsite due to lower transportation and disposal costs. Onsite controlled landfill costs are moderate to high and onsite uncontrolled land disposal costs are low to moderate. Disposal in the subject site excavation would provide the lowest cost option. Landfill capacity limitations and potential institutional factors may limit the use of onsite disposal. Currently, a ban exists prohibiting the offsite transport of wastes from ORR; therefore, offsite disposal is not a preferred disposal option. Offsite controlled landfill costs are high and offsite uncontrolled land disposal costs are moderate to high.

7.2.2.2 Groundwater Remediation Evaluation

The groundwater general response actions and remedial technologies evaluated in this section include: removal/extraction, collection/control, biological treatment, chemical treatment, physical treatment, treatment at onsite wastewater treatment facilities, in situ treatment, and disposal/discharge. Groundwater monitoring does not achieve corrective action objectives by itself but is considered an integral part of any groundwater remediation activity.

The criteria described in section 7.2.1 were used to evaluate the remedial technologies within each of the groundwater general response actions remaining after the initial screening. The purpose of this evaluation is to identify the most effective, implementable, and cost-effective process options for attaining the Building 9201-1 Site corrective action objectives for groundwater remediation.

Table 7-4 provides a summary of the evaluation of the remaining process options for contaminated groundwater at the Building 9201-1 Site.

Removal/Extraction

The removal/extraction action of pumping methods using extraction wells or injection/extraction wells would effectively eliminate groundwater contamination from the site, but would bring to the surface a large volume of aqueous waste requiring treatment and/or disposal. Short-term considerations of worker safety and environmental impacts due to drilling operations would be considered by development and implementation of a Health and Safety Plan for the drilling activities, the control of drilling spoils, and the inclusion of surface water runoff/runoff control in the corrective action design.

Conventional drilling and pumping equipment would be used for the development of wells and for the extraction of the contaminated groundwater at the site and, therefore, this action is readily implementable. The Building 9201-1 Site is adjacent to an active loading area within the exclusion zone of the Y-12 Plant and includes buildings and utilities in close proximity to the contaminated area. The site-specific constraints may impact the time-frame for implementation of extraction actions.

The capital costs for the extraction actions are moderate with low O&M costs.

Collection/Control

The collection/control action of interceptor trenches used as subsurface drains is an effective process for the interception of fracture flow downgradient of the contamination source. This method may be used to enhance the extraction actions but is very difficult to implement because it may require deep trenching through rock. This activity also involves an increased risk to worker safety due to possible trench collapse and an increased risk to worker health due to increased potential of contact with the contaminated groundwater.

Large trenching equipment is available for constructing interceptor trenches; the capital costs would be high, although the O&M costs would be low.

Table 7-4. Evaluation of Process Options for Groundwater Remediation at the Building 9201-1 Site

| Groundwater General Response Action | Remedial Technology | Process Options | Effectiveness | Implementability | Cost |
|-------------------------------------|--|--|---|--|--|
| Removal/ Extraction | Pumping | <div style="display: flex; flex-direction: column; align-items: center;"> <div style="border: 1px solid black; padding: 2px; margin-bottom: 5px;">Extraction Wells</div> <div style="border: 1px solid black; padding: 2px; margin-bottom: 5px;">Extraction/ Injection Wells</div> </div> | <p>An effective and reliable removal/extraction method.</p> <p>An effective and reliable removal/extraction method.</p> | <p>Easily implemented.</p> <p>Easily implemented. Permit required for injection well.</p> | <p>Moderate capital, low O&M.</p> <p>Moderate capital, low O&M.</p> |
| Collection/ Control | Subsurface Drains | <div style="display: flex; flex-direction: column; align-items: center;"> <div style="border: 1px solid black; padding: 2px;">Interceptor Trenches</div> </div> | <p>Effective for downgradient fracture flow interception.</p> | <p>Very difficult to implement. May require deep trenching through rock and increased exposure risk to workers.</p> | <p>High capital, low O&M.</p> |
| Treatment | <div style="display: flex; flex-direction: column; align-items: center;"> <div style="border: 1px solid black; padding: 2px; margin-bottom: 5px;">Biological Treatment</div> <div style="border: 1px solid black; padding: 2px;">Chemical Treatment</div> </div> | <div style="display: flex; flex-direction: column; align-items: center;"> <div style="border: 1px solid black; padding: 2px; margin-bottom: 5px;">Slurry-Phase Bioremediation</div> <div style="border: 1px solid black; padding: 2px; margin-bottom: 5px;">Neutralization</div> <div style="border: 1px solid black; padding: 2px;">Oxidation/ Reduction</div> </div> | <p>Effective and reliable conventional technology.</p> <p>The process increases the effectiveness of other treatment processes but does not fully treat contaminants alone.</p> <p>Effective as a pretreatment step, but does not fully treat contaminants alone.</p> | <p>Readily implementable.</p> <p>Easily implemented.</p> <p>Readily implemented, but requires constant reagent addition.</p> | <p>Moderate capital, moderate O&M.</p> <p>Low capital, low O&M.</p> <p>Moderate capital, high O&M.</p> |

7-49

Table 7-4. (continued)

| Groundwater General Response Action | Remedial Technology | Process Options | Effectiveness | Implementability | Cost |
|-------------------------------------|---|--|---|--|---|
| <p>Treatment (Cont'd)</p> | <p>Physical Treatment</p> | <p>Tray Aeration</p> | <p>Effective and reliable for removing volatile fraction.</p> | <p>Easily implemented.</p> | <p>Moderate capital, low O&M.</p> |
| | <p>Filtration</p> | <p>An effective and necessary pretreatment process, but does not treat the contaminants of concern.</p> | <p>Easily implemented.</p> | <p>Very low capital, low O&M.</p> | |
| | <p>Carbon Adsorption</p> | <p>An effective and reliable treatment process; however, it produces a secondary waste.</p> | <p>Readily implemented. Spent carbon adsorption units must be disposed.</p> | <p>Moderate capital, low O&M, high disposal.</p> | |
| | <p>Air Stripping</p> | <p>An effective and reliable treatment method for removing VOCs, but VOCs are not the only contaminant of concern.</p> | <p>Very easily implemented.</p> | <p>Low capital, low O&M.</p> | |
| | <p>Steam Stripping</p> | <p>An effective and reliable treatment method for removing more soluble volatile fraction.</p> | <p>Not easily implemented.</p> | <p>High capital, moderate O&M.</p> | |
| | <p>Distillation</p> | <p>Effective and reliable.</p> | <p>Difficult to implement.</p> | <p>High capital, moderate to high O&M.</p> | |
| | <p>Thin-film Evaporation</p> | <p>Most effective for removing viscous volatile constituents, but gasoline components are not viscous.</p> | <p>Not readily implementable.</p> | <p>Very high capital, high O&M.</p> | |
| | <p>In Situ Treatment</p> | <p>Indigenous Bacteria</p> | <p>An effective and reliable natural treatment process.</p> | <p>Generally easy to implement; requires treatability study.</p> | <p>Low to moderate capital, moderate O&M.</p> |
| | <p>Selective Bacteria</p> | <p>An effective and reliable process.</p> | <p>Generally easy to implement; requires treatability study.</p> | <p>Low to moderate capital, moderate O&M.</p> | |
| | <p>Y-12 Wastewater Treatment Operations</p> | <p>Various Treatment Technologies</p> | <p>A proven effective and reliable operation.</p> | <p>Currently treating similar wastewater.</p> | <p>Very low capital, low O&M.</p> |

7-50

Table 7-4. (continued)

| Groundwater General Response Action | Remedial Technology | Process Options | Effectiveness | Implementability | Cost |
|-------------------------------------|--------------------------|-----------------------------------|--------------------------------|---|---------------------------------------|
| <p>Disposal/ Discharge</p> | <p>Onsite Discharge</p> | <p>Reinjection Wells</p> | <p>Effective and reliable.</p> | <p>Readily implementable. Permit required.</p> | <p>Moderate capital, low O&M.</p> |
| | | <p>Surface Water</p> | <p>Effective and reliable.</p> | <p>Readily implementable. Permit required.</p> | <p>Low capital, very low O&M.</p> |
| | | <p>Infiltration Gallery</p> | <p>Effective and reliable.</p> | <p>Slightly difficult to implement.</p> | <p>Moderate capital, low O&M.</p> |
| | | <p>Y-12 WTO Permitted Outfall</p> | <p>Effective and reliable.</p> | <p>Readily implementable. Required permits are in place.</p> | <p>Low capital, very low O&M.</p> |
| | <p>Offsite Discharge</p> | <p>Streams Offsite</p> | <p>Effective and reliable.</p> | <p>Not readily implementable due to moratorium on offsite disposal of low level waste. Permit required.</p> | <p>High capital, low O&M.</p> |

7-51

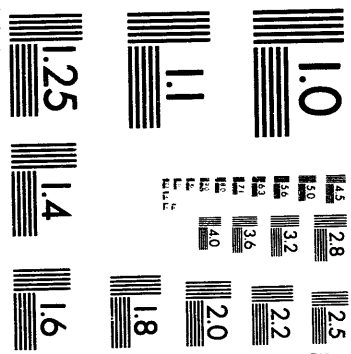

2 of 2

Biological Treatment (Slurry-Phase Bioremediation)

Biological treatment of the extracted groundwater would involve aerobic degradation by a slurry-phase bioremediation process. A bioaugmentation (addition of microorganisms) biological treatment process involves the extraction of the contaminated groundwater and mixing of contaminated soil to create a slurry. The slurry would be treated in a bioreactor where oxygen, nutrients, and microbes can be added, as needed, during the operation of the process.

Biological treatment would remove the contaminated groundwater by extraction, and treatment operations would destroy the petroleum contaminants completely. This option would satisfy the corrective action objectives identified for the groundwater. This technology has not been previously implemented at ORR, but has been used at other petroleum contaminated sites.

Administrative and regulatory considerations may impact the implementability of this option due to potential permit requirements and/or environmental impact evaluations. There would be no long-term management of residual contamination from the treatment process due to the complete destruction of the contaminants of concern. There are vendors available with the necessary equipment and skilled workers to implement this technology. Capital costs would be moderate with moderate O&M.

Chemical Treatment

The chemical treatment processes evaluated included neutralization and oxidation/reduction processes.

The *neutralization* process increases the effectiveness of other treatment processes, but does not effectively treat or remediate the contaminants of concern. Common chemicals may be added manually or automatically by a treatment process system to adjust the pH to proper levels; therefore, the process is easily implemented. Capital costs of this process are low and O&M costs are low in comparison with other treatment processes.

Oxidation/reduction treatment processes are effective as pretreatment steps, but do not effectively treat or remediate the contaminants of concern. Chemicals, such as hydrogen peroxide, are readily available, but because they are highly reactive, they require constant addition to bring about a reduction/oxidation (REDOX) reaction. Because of the large volume of contaminated groundwater, capital costs are considered moderate and O&M costs high.

Physical Treatment

The physical treatment processes evaluated include tray aeration, filtration, carbon adsorption, air stripping, steam stripping, distillation, and thin-film evaporation.

Tray aeration is an effective and reliable treatment process for the removal of VOCs from groundwater. Transportable units are commercially available; therefore the process is easy to implement. Capital costs are moderate and O&M costs are low.

Filtration is an effective and necessary pretreatment step in any treatment process, but does not in itself treat the contaminants of concern. The process is easily implemented and filtration devices are readily available. Capital costs are very low and O&M costs are low. This process option will be considered in combination with other physical and biological treatment options.

Carbon adsorption is an effective and reliable treatment process for the removal of petroleum contaminants from groundwater. It is most often used as a post-treatment or polishing step of other treatment processes; however, the used carbon filter canisters become a secondary waste and require proper disposal. Carbon filters are readily available for this application. The capital cost of this process option is moderate and the O&M is low; however, the disposal costs are high.

Air stripping is an effective and reliable treatment process for the removal of VOCs from the groundwater; however, VOCs are not the only contaminant of concern. Commercial mobile units are locally available; therefore, the process is very easy to implement. Capital costs and O&M costs are low.

Steam stripping is a more effective and reliable treatment process for the removal of less volatile and more soluble contaminant fractions from groundwater than air stripping. Steam stripping units are energy intensive and sophisticated devices; therefore, the process is not easily implemented. Capital costs are high and O&M costs are moderate.

Distillation is an effective and reliable treatment process for separation of contaminants based on volatility differences. This process is very energy intensive and requires an extensive amount of equipment to be brought onsite; therefore, it is difficult to implement. The capital costs are considered high and O&M costs are moderate to high.

Thin-film evaporation is effective for removing volatile constituents in solutions that are too viscous to separate by other distillation/evaporation processes, but gasoline components are not extremely viscous petroleum products. Although several companies manufacture the process units, the process has limitations that require pretreatment and post-treatment steps; therefore, it is not readily implementable. The capital costs are very high and O&M costs are high.

Onsite Treatment at Wastewater Treatment Facilities

This technique would involve sampling and characterization of extracted groundwater by Waste Treatment Operations (WTOs). A determination will be made based on available capacities, constituents, and concentrations as to whether the water will be treated at the West End Treatment Facility (WETF), Groundwater Treatment Facility (GWTF), or the Central Pollution Control Facility (CPCF). After treatment, the effluent will be released to East Fork Poplar Creek at NPDES outfall #502 for WETF, NPDES outfall #512 for GWTF, or NPDES outfall #501 for CPCF.

This approach would result in the efficient removal of petroleum contaminants from groundwater, equipment needs are minimal and readily available, no treatability study is required (other than pre-treatment sampling), human health and environmental concerns associated with implementation will be minimal, the approach will be very low-cost, and the technical requirements associated with it will be manageable.

In Situ Treatment

In situ treatment processes evaluated included indigenous and selective bacteria processes. With these processes, groundwater would be extracted to the surface where oxygen, nutrients, and microbes would be added prior to reinjection. Both processes are similar except the indigenous process uses naturally occurring bacteria and the selective bacteria process uses specially cultured microorganisms to carry out the biodegradation process. Both processes are effective and reliable treatment processes and have been used at similar petroleum contaminated sites. Either process would require a treatability study to determine oxygen, nutrient, microbes, and other environmental needs to effectively treat the contaminated groundwater at the Building 9201-1 Site, but either is generally easy to implement. The capital costs of both processes are low to moderate and the O&M costs are considered moderate.

Disposal/Discharge (Onsite/Offsite)

Disposal/discharge actions involve the release of treated groundwater and groundwater treatment residual waste either onsite or offsite. The waste materials are not currently considered to meet the definition of a RCRA hazardous waste. If the treated or untreated waste materials do meet the definition of RCRA hazardous waste, the disposal options will be amended to include the RCRA regulatory requirements.

Onsite discharge options include reinjection wells, surface waters, infiltration galleries, and discharge through Y-12 WTOs. All onsite discharge options are considered effective and reliable. With the exception of infiltration galleries being slightly more difficult to implement, these processes are considered readily implementable, but they require an NPDES and/or TDEC permit. Reinjection wells and infiltration galleries have moderate capital costs and low O&M costs. The surface water discharge process has low capital and very low O&M costs. Disposal through the Y-12 WTOs was discussed previously.

The only option for discharge offsite is the piping of treated groundwater to offsite streams for release. Offsite options for discharge are least preferred due to the ORR moratorium on transport of low-level waste offsite; therefore, offsite discharge is not currently readily implementable. In addition, an NPDES permit is required. Capital costs for this option are considered high in relation to other discharge options; however, O&M costs are considered low.

7.2.3 Summary Of Top Three Selected Corrective Action Options

7.2.3.1 Corrective Action Options for Soil Remediation

The three corrective action options considered to be best for the specific petroleum contaminants in the soils at the Building 9201-1 Site involve a combination of removal, treatment, and disposal general response actions. All of the corrective actions considered involve excavation of the contaminated soil prior to treatment. The selected treatment technologies are thermal desorption, land aeration, and solid-phase bioremediation.

Table 7-5 outlines specific requirements of the treatment technology associated with each of the selected corrective action options. The thermal desorption treatment technique is expected to result in a treated waste suitable for unrestricted disposal or disposal at the Y-12 Centralized Landfill

Table 7-5. Technology Specific Requirements of Top Three Soil Corrective Action Options for the Building 9201-1 Site

| Requirement | Thermal Desorption | Land Aeration | Solid-Phase Bioremediation |
|-------------------------|---------------------|------------------------|----------------------------|
| Water | 20-100 gpm | None | 0-20gpm |
| Power | 480 V | None | 120V |
| Fuel | Propane | None | None |
| Area (footprint) | 150' x 130' or less | 10,000 ft ² | 15,000 ft ² |
| Area (laydown) | Soil Pile | None | None |
| % Efficiency | 99.9% | 95% | 99% |
| Personnel Needs | 4 - 5 | 0 - 3 | 0 - 3 |
| Local Personnel | 3 | 0 - 2 | 2 |
| Equipment Needed | Yes | No | No |
| Time of Treatment | 2-3 months | 4-10 months | 3-8 months |
| Treatability Study | Yes | No | Yes |
| Cost \$/yd ³ | \$30-100 | \$20 | \$25-50 |
| Secondary Waste Stream | No | No | No |

This information was obtained by phone interview with technology vendors between March 17 and March 20, 1992, and on April 30, 1992.

facility. Land aeration bioremediation is expected to allow unrestricted disposal. Solid phase bioremediation is expected to allow unrestricted disposal, preferably with the treated soil remaining at the treatment site.

Advantages and Disadvantages

Since the excavation technique will be the same regardless of the chosen treatment technology, the following discussion only addresses the advantages and disadvantages of the treatment technology and the final disposal requirement. The descriptions below are summarized in Table 7-6.

NOTE: Vendors of the remaining options were contacted and questioned using a standard list of requirements. The advantages and disadvantages were determined from the answers to these questions.

Thermal Desorption. Thermal desorption involves the destruction of all organic contaminants by heating above 200° F. Thermal desorption physically separates volatile and some semivolatile contaminants from the contaminated soil. The thermal desorption process heats the contaminated media to between 200° and 600° F, driving off water and volatile contaminants. While there are several different types of combustors used in the process by different vendors, the main concept behind the technology is similar for them all. Soil is placed in the combustor where it is heated long enough to drive hydrocarbons from it. Dust from the exhaust is collected in a baghouse or scrubber and then joined with the treated waste stream. The hydrocarbons, in a vapor form, are either incinerated in a separate afterburner at a much higher temperature or are cooled to condense and reduce their volume and are adsorbed by carbon filters. The carbon filter air pollution control system generates a waste stream that requires additional treatment and/or disposal in a controlled landfill. Soil is separated as a clean product, and since the soil is still very hot and dusty, most systems water it for dust control, cooling, and to maintain soil workability. After confirmatory sampling, the soil is ready for use as fill material or landfill cover. The treated soil may be considered for uncontrolled disposal; however, the product from thermal desorption is considered a sterile product. It can be mixed with organics to create a soil that can sustain vegetation. The soil can also be disposed of and covered with topsoil to sustain plant life.

Mobile thermal desorption units capable of treating contaminated soil are commercially available for rental or purchase. Permitting and environmental impact considerations of this process, as well as site-specific considerations for mobilization, would have to be considered. An evaluation would be conducted to define the operational parameters of this treatment option in relation to the

Table 7-6. Advantages and Disadvantages of Top Three Soil Corrective Action Options for the Building 9201-1 Site

| Technology | Advantages | Disadvantages |
|----------------------------|--|---|
| Thermal Desorption | <ul style="list-style-type: none"> • 1 month to complete • No waste streams created • 150' x 130' area required • Very predictable success | <ul style="list-style-type: none"> • Equipment onsite • Variable cost (\$30-100/yd³) • Sterile soil after treatment • Requires power, water and fuel |
| Land Aeration | <ul style="list-style-type: none"> • No onsite equipment • Low cost (\$20/yd³) • No utilities required • Fertile soil after treatment • No waste streams created | <ul style="list-style-type: none"> • 4-10 months to complete • 10,000 ft² area required • Not totally predictable |
| Solid Phase Bioremediation | <ul style="list-style-type: none"> • No equipment onsite • Low cost (\$25-50/yd³) • Low utility requirements • Fertile soil after treatment • No waste streams created | <ul style="list-style-type: none"> • 3-8 months to complete • 15,000 ft² area required • Results not predictable from treatability study |

contaminated soil. If the treatment is not meeting target concentrations, higher heat or longer exposure can be applied to complete the desorption. However, the cleanup efficiency of the process is very predictable at 99.9%. The volume requiring treatment could be treated in less than 1 month. The only waste streams created are an air discharge that can be monitored and permitted and carbon filter canisters that must be disposed of, if they are used.

Thermal desorption requires that treatment equipment be brought onsite. The 150' × 130' area required for the equipment is the smallest area needed for any of the treatment options. This equipment does not require a great deal of room but runs the risk of radiological contamination. A concrete pad, or other suitable laydown area, is required to stockpile the soil before and after treatment. Personnel needs are 4 to 5 operators; 2 or 3 operators can be from the local work force. The equipment requires 480 volts at 600 amps of operating power, a substantial amount of propane fuel, and 20-100 gpm of water to re-hydrate and cool the soil after desorption. Thermal desorption costs vary from low to high at \$30-\$100/yd³.

Land Aeration

Passive treatment of the excavated contaminated soil would involve land aeration of the soil to remove volatile organics. This process is particularly cost effective at remediation sites contaminated with gasoline. The contaminated soil is first mechanically screened to remove large stones and debris and create voids in the material. The soil is then spread over a synthetic liner in a treatment area in a layer as thin as 1 ft. Periodic tilling maintains air contact with the contaminated soil and promotes volatilization of the BTX contamination. After treatment the soil would be usable for uncontrolled disposal as fill material or for direct land application.

Land aeration is a low technology treatment method and can be performed by the property owner without vendor assistance. If the contamination is primarily VOCs, the soil is assumed to be a candidate for the method and no treatment studies are performed. The contaminated soil is spread out so the contamination can volatilize into the environment and be periodically tilled. The end product is the soil with petroleum contamination removed.

A suitable disposal technique for the soil after land aeration would be disposal at the location of the aeration bed. The soil could be covered with topsoil and seeded or used for fill material at another location. Land aeration does not require that additional equipment be brought on site for the treatment process. There would not be a risk of radiological contamination of vendor owned equipment. There are no utility or fuel requirements for soil aeration. The soil requires no further

treatment to sustain vegetation after the volatilization of the VOCs. There are no additional waste streams created.

If the contamination is primarily VOCs and the site conditions are favorable, soil aeration is very predictable in its ability to remove contamination. Warm, arid days will result in a faster treatment time while cool, damp days will extend the time required for treatment. A spring season start and optimum conditions could allow a treatment time as short as 4 months. For comparison purposes a treatment time of 4-10 months is assumed. The only costs for land aeration are the liner for the treatment bed and the synthetic cover to limit rain infiltration into the treatment bed. This cost is \$20/yd³ for both liners. Personnel needs range from 3 during bed preparation to 1 during the aeration process, with all of the personnel from the local workforce.

A level area of approximately 10,000 ft² is required to place the liner and spread the soil in a layer that may need to be as thin as 1 ft. No additional laydown area is required. There is, however, a shortage of usable and available land space at the Y-12 facility. Because of the large land space required and the possibility of environmental impact, an Environmental Assessment (EA), as mandated by the National Environmental Policy Act (NEPA), would be required for siting of the facility. The time frame for completion of the EA is estimated by the Y-12 NEPA group to be approximately 2 years.

Solid Phase Bioremediation. Biological treatment of the excavated contaminated soil would involve aerobic degradation by a solid phase bioremediation process. A bioaugmentation (addition of microorganisms) biological treatment process includes excavating the contaminated soil and transporting it to a designated location for biological treatment. The excavated soil is placed in a lined treatment bed or biological cell at a uniform depth where the bacteria and nutrients are applied. An aeration system to supply oxygen and an aqueous nutrient addition system would be used. Aerobic biological degradation would provide for the complete destruction of the petroleum hydrocarbon contaminants upon completion of the treatment action. The remaining soil would be usable for uncontrolled disposal as fill material or for direct land application.

Aerobic bacteria are used to treat contaminants in solid phase bioremediation. The end products of the biodegradation process are carbon dioxide, water, and bacterial biomass. The technology uses special strains of cultured bacteria and microorganisms occurring naturally in the soils and groundwater to break down the hydrocarbons. Solid phase bioremediation is specifically tailored to site conditions. Soil conditions and contaminant types as well as treatment goals must be

considered in decisions about what type of bacteria and nutrients to use, as well as with regard to the variables of pH, temperature, and dissolved oxygen.

A comprehensive treatability study would be conducted to define the operational parameters of this treatment option in relation to the contaminated soil. The type of microbe, nutrient levels, oxygen addition, and expected time frame would be defined.

The entire volume of soil treated by bioremediation would be eligible for uncontrolled disposal. The soil could be covered with topsoil and seeded at the treatment site as a means of disposal. Solid phase bioremediation does not require capital equipment to be brought onto the Y-12 Plant, eliminating potential risk of contamination. The process has a low utility requirement of 0 to 20 gpm of water and 120V electric power supply due to lack of large equipment needs. The area used for treatment will need to be periodically watered and tilled for aeration to create an ideal environment for the bacteria to break down the contamination. After the bacteria have broken down the contamination, they die; the soil is ready for uncontrolled disposal and may be fertile for growth. The process does not create additional waste streams while remediating the original contamination since any collected leachate can be reapplied to the soil.

Solid phase bioremediation is not totally predictable. The cost, and more importantly, the time required for treatment is not accurately known. The performance of the microorganisms is widely dependent on the soil conditions. Nutrients can be added to optimize their performance. Bioremediation is the slowest of the treatment options, requiring up to one year; however, most vendors indicate that the process could take as little as 2 months. For estimation purposes, the bioremediation process is expected to last 3 to 8 months. Solid phase bioremediation is relatively inexpensive at \$25-\$50/yd³. Personnel needs range from 3 during treatment bed preparation to zero during the passive degradation process, with an average of 2 from the local work force.

A relatively large level area of 15,000 ft² is required to construct the perimeter berms, place the liner, and spread the soil in a layer that may need to be as thin as 1 ft. No laydown area is required; however, other small areas will be needed for leachate collection, soil screening, and nutrient addition storage/mixing. As mentioned previously, there is a shortage of usable and available space at the Y-12 facility, and there would be a NEPA requirement for an EA.

Projected Remediation Periods

Estimates of treatment time required were obtained through telephone conversations with technology vendors. It is estimated that approximately 100 yd³ of soil will be excavated. Assuming a swell of 30% yields 130 yd³ of loose soil. Time frames were obtained based on preliminary information; actual remediation time is expected to vary. All technologies have a common excavation time period. Excavation should proceed faster than any of the remediation options and will be able to run concurrently with soil decontamination. Excavation should take less than one month for all corrective actions considered. Table 7-7 contains a summary of projected remediation periods.

Thermal Desorption. The 130 yd³ of contaminated soil could be treated by thermal desorption in less than 1 month. After treatment, it is expected to take approximately 1 additional month to dispose of the treated soils. The total remediation period is expected to last less than 2 months.

Land Aeration. Land aeration should take 4-10 months to treat the contaminated soil. After treatment, it is expected to take approximately 1 month to dispose of the treated soils. The remediation period is expected to take 5-11 months.

Solid Phase Bioremediation. Depending on climatic conditions, solid phase bioremediation should take between 3 and 8 months. After treatment, it is expected that the soil and liner could remain in place; therefore, the disposal period is null. Alternatively, decommissioning of the treatment cell, reapplication of the clean soil, and disposal of the liner should take less than 1 month. The total remediation period is expected to last 4 to 9 months.

7.2.3.2 Corrective Action Options for Groundwater Remediation

The three corrective action options considered to be best for the specific groundwater petroleum contaminants at the Building 9201-1 Site involve a combination of extraction, treatment, and discharge general response actions. All of the corrective actions considered involve extraction of the contaminated groundwater prior to, or during, treatment (i.e., pump-and-treat). The treatment technologies are tray aeration, air stripping, and onsite wastewater treatment facilities.

Table 7-7. Projected Remediation Periods of Top Three Soil Corrective Action Options for the Building 9201-1 Site

| Treatment Technology | Excavation | Treatment | Disposal/ Closure | Total Period |
|----------------------------|------------|-------------|----------------------|--------------|
| Thermal Desorption | 1 month | <1 month | 1 month | <2 months |
| Land Aeration | 1 month | 4-10 months | 1 month | 5-11 months |
| Solid Phase Bioremediation | 1 month | 3-8 months | 1 month | 4-9 months |

Note: The 1 month of excavation can run concurrently with treatment. Disposal could also take place concurrently with treatment; however, the total period is conservatively assumed as cumulative of treatment and disposal/closure time.

The comparison of the top three potential corrective action options for groundwater remediation is based on the following assumptions:

- The effective saturated soil porosity is 10%.
- Groundwater flow is essentially horizontal and the effective thickness of groundwater to be extracted is 8 ft.
- Preliminary estimate of the areal extent of the contaminant plume is approximately 2,300 ft².
- Assumed contaminated groundwater volume is approximately 13,760 gallons (basis: 10% × 8 ft × 2,300 ft² × 7.48 gal/ft³).
- Due to potential chemical partitioning, it is assumed that an equivalent of 10 contaminant volumes will be extracted for treatment, or 137,600 gallons.

Table 7-8 outlines specific requirements of the treatment technology for each of the selected corrective action options. All three treatment technologies are expected to allow unrestricted discharge of treated groundwater.

Advantages and Disadvantages

Since the extraction technique (i.e., pumping from recovery wells) will be the same regardless of the chosen treatment technology, the following discussion only addresses the advantages and disadvantages of the treatment technology and the final disposal requirement. The process rates used for comparison only involve the limitation of the process treatment unit and not other system limitations, such as pump rate. The descriptions below are summarized in Table 7-9.

Tray Aeration. Volatile contaminants are driven from affected groundwater in an aeration unit by forcing air through the water. As the water flows through a tray, air is pumped through holes in the bottom of the tray.

A specific feature of tray aeration units is compact size. The self-contained unit requires a footprint of 4' × 3' and is only 6 ft high, requiring no special mounting pads or laydown area. Electrical requirements are 220V, single phase. Equipment to treat the Building 9201-1 Site groundwater contamination could operate at a process flow rate of 10 gallons per minute (gpm). Aeration systems operate at efficiencies up to 92% for single tray (ST) models and 99% for dual tray (DT) models. Aeration efficiency would be greater in the summer months with higher ambient

Table 7-8. Technology Specific Requirements of Top Three Groundwater Corrective Action Options for the Building 9201-1 Site

| Requirement | Tray Aeration | Air Stripping | Onsite Wastewater Treatment Operations (WTO) |
|--------------------------|-------------------|--------------------|--|
| Process (Treatment) Rate | 10 gpm | 5-10 gpm | Dependent on other system limitations |
| Power | 220 V | 220 V | * |
| Area (setup) | 4' x 3' | 6' x 12' or less | * |
| Op. Temperature | Ambient | Ambient | Ambient |
| % Efficiency | 92% (ST) 99% (DT) | 98%(VOC) 88% (SVC) | 99% |
| Personnel Needs | 0 - 1 | 0 - 1 | * |
| Local Personnel | 0 | 0 | * |
| Equipment Needed | Yes | Yes | * |
| Time of Treatment | <1 month | 1 - 3 months | <1 month |
| Treatability Study | No | No | No |
| Cost \$/100 gal. | \$2.00 - \$2.50 | \$2.00 - \$2.50 | * |
| Secondary Waste Stream | No | No | No |

* WTO includes three operating facilities. No additional equipment, power, area, or personnel will be required.

This information was obtained by phone interview and correspondence with technology vendors between April 30, 1992 and August 5, 1993, and review of EPA *Engineering Bulletins*.

Table 7-9. Advantages and Disadvantages of Top Three Groundwater Corrective Action Options for the Building 9201-1 Site

| Technology | Advantages | Disadvantages |
|--|--|---|
| Tray Aeration | <ul style="list-style-type: none"> • Less than 1 month to complete • Low cost at \$2.00 - \$2.50/100 gal. • Predictable success • Minimal equipment onsite • Very small (4'x3') setup area • Low maintenance | <ul style="list-style-type: none"> • Low efficiency (92%) if single tray unit used • Requires permit for surface water discharge |
| Air Stripping | <ul style="list-style-type: none"> • 1-3 months to complete • Low cost at \$2.00 - \$2.50/100 gal. • Predictable success • Minimal equipment onsite • Small 6'x12' setup area • Low maintenance | <ul style="list-style-type: none"> • Low efficiency (88%) for semivolatle compounds • Requires permit for surface water discharge |
| Onsite Wastewater Treatment Facilities | <ul style="list-style-type: none"> • Less than 1 month to complete • No additional equipment • Requires no additional permit for surface water discharge • Treatability study not required • No additional maintenance • Negligible cost • Predictable success • No additional set-up area | <ul style="list-style-type: none"> • Requires filtration, collection, and transport |

temperatures. Assuming one DT aeration unit and 137,600 gallons of groundwater to be treated, the treatment would take less than one month. Operating costs for the units range from \$2.00 to \$2.50/ 100 gallons treated.

Those units are low maintenance items and are not required to be manned at all times; however, one skilled operator is needed for setup, monitoring, and adjusting. After treatment the most inexpensive method of releasing the decontaminated water will be release to the storm sewer system. Additional NPDES and TDEC permitting may be required for this discharge. Another alternative is to allow the treated water to recharge the groundwater through an infiltration gallery. The unit does not generate any secondary waste stream requiring further treatment.

Air Stripping (EPA, 1991a & 1991b). Air stripping is a mass transfer process in which volatile contaminants in groundwater are evaporated into the air. Important operation factors are temperature, pressure, air to water ratio, and surface area available for mass transfer. Residuals of the process are hydrocarbons and effluent water. This process is used to treat aqueous organic waste with relatively high volatility and low water solubility, such as gasoline.

Air stripping equipment is available as self-contained mobile units with various capacities. These units are most often cylindrical packed towers filled with plastic media of various shapes. Typically, a small set-down area 6' x 12' per unit is all that is required. Electrical requirements are 220V, single phase, 40 amps (standard). Process rates are 5 to 10 gpm per unit and multiple units can be applied. Efficiencies are greater than 98% for VOCs and 80% for semivolatile compounds. Air stripping is typically performed at ambient temperature, but higher temperatures improve the efficiency. These units are low maintenance items and are not required to be manned at all times, but one skilled operator is needed for monitoring and adjusting the unit. Assuming 1 mobile unit operating continuously at 5 gpm and 137,600 gallons of water, the treatment period would be less than 1 month. Assuming a three-month minimum rental rate, the operating costs for a small mobile unit would range from \$2.00 to \$2.50/100 gallons treated.

After treatment the most inexpensive method of releasing the decontaminated water will be release to the storm sewer system. Additional NPDES and TDEC permitting may be required for this discharge. Another alternative is to allow the treated water to recharge the groundwater through an infiltration gallery. The unit does not generate any secondary waste stream requiring further treatment.

Onsite Wastewater Treatment Facilities. Treatment of contaminated groundwater at onsite wastewater treatment facilities involves initial extraction of contaminated groundwater using a conventional recovery system, transfer at the 9201-1 Site into a tanker truck, and transport of groundwater to the appropriate facility for treatment.

The Y-12 WTO personnel have extensive experience in treating contaminated liquid waste streams from the Oak Ridge Reservation (ORR). The nature of the groundwater will allow them to choose the optimal treatment system for the known contaminants on a per tanker basis. The capability exists at one or more of the treatment facilities to treat the groundwater for contaminants other than the expected benzene/toluene/xylenes (BTX) and total petroleum hydrocarbon (TPH) contaminants. The proposed treatment facilities are the WETF, the GWTF, and the CPCF.

WETF

The WETF, including the West Tank Farm (WTF), is designed to treat nitrate bearing aqueous waste from Y-12 treatment operations. The waste streams treated at the WETF/WTF consist of nitric acid waste, rinse waters, groundwaters, mixed acid wastes, waste coolants, mop waters, and caustic waters. Treatment for nitrates is carried out by biological denitrification at the WTF. The treatment operations used consist of biological denitrification, biological oxidation, metals precipitation, coagulation, flocculation, clarification, filtration, and carbon adsorption. Effluent from the WETF is discharged through an NPDES permit, Serial Number Discharge 502 into East Fork Poplar Creek.

GWTF

The GWTF is designed to remove volatile and non-volatile organic compounds and iron from area groundwaters. The GWTF uses precipitation/filtration to remove iron, an air stripping operation to remove volatile organics, and carbon adsorption to remove non-volatile organics. The GWTF-treated effluent is discharged through an NPDES permit, Serial Number Discharge 512 into East Fork Poplar Creek. Treatment at the GWTF is limited due to the present load on the facility.

CPCF

The CPCF is designed to treat mop water and non-nitrate bearing waste streams. The waste waters to be treated are categorized as dilute wastewater or mop waters, acidic wastes, caustic wastes, and plating rinse waters. These general categories of wastes cover a broad range of chemical

compositions and concentrations, and may include significant quantities of heavy metals, acids, and bases. The CPCF process consists of several unit operations that are used in batch and semi-batch operations. These unit operations include, but are not limited to, heavy metal precipitation, flocculation, coagulation, clarification, carbon adsorption, and filtration. Effluent from the CPCF is discharged through an NPDES permit, Serial Number Discharge 501 into East Fork Poplar Creek.

Projected Remediation Periods

Estimates of treatment time required were obtained through telephone conversations with technology vendors. It is estimated that approximately 137,600 gallons of contaminated groundwater will be extracted for ex situ treatment. Time frames were obtained based on preliminary information; actual remediation time is expected to vary. All technologies have a common extraction well development time period. It is assumed that one month of extraction/injection well development takes place before treatment begins. Table 7-10 contains a summary of the projected remediation periods.

Tray Aeration. Tray aeration would take less than 1 month to treat the contaminated groundwater at the Building 9201-1 Site. After the groundwater has been processed by the treatment unit it is assumed that the effluent could be discharged to the local streams (assuming an NPDES/TDEC permit is granted), and could be discharged directly from the unit concurrently with treatment. Including 1 month to install the extraction wells and set up equipment, plus 1 month to close wells and remove equipment, remediation using this technology would require a total of less than 3 months.

Air Stripping. This process would take about 1 to 3 months. After treatment, it is expected that the groundwater could be discharged to local streams (assuming an NPDES/TDEC permit is granted), which could take place concurrently with treatment. Including 1 month to install the extraction wells and set up equipment, plus 1 month to close wells and remove equipment, this remediation technology would require a total of 3 to 5 months.

Onsite Wastewater Treatment Facility. Installation of extraction wells is anticipated to take 1 month. Residence time in the appropriate treatment facility will be minimal. After the contaminated groundwater is treated in one of the treatment facilities onsite, it is discharged to surface waters at a designated NPDES discharge point. Well closure and equipment removal will require approximately 1 month, resulting in a total remediation period of less than 3 months.

**Table 7-10. Projected Remediation Periods of Top Three Groundwater
Corrective Action Options for the Building 9201-1 Site**

| Treatment Technology | Well Development | Treatment | Closure | Total Period |
|-----------------------------|-----------------------------|------------------|----------------|---------------------|
| Tray Aeration | 1 month | <1 month | 1 month | <3 months |
| Air Stripping | 1 month | 1-3 months | 1 month | 3-5 months |
| Onsite Treatment Facilities | 1 month | <1 month | 1 month | <3 months |

Note: One month of well development and treatment equipment setup is assumed concurrent. One month of equipment dismantling and removal and well closure is assumed. Total period is the cumulative of well development, treatment, and closure.

8.0 CORRECTIVE ACTIONS CHOSEN

8.1 Soil Corrective Action

8.1.1 General Description of Soil Corrective Action

Based on an evaluation of all criteria associated with the corrective action options discussed in Section 7.2, a combination of process options is proposed for remediation of petroleum contaminated soils at the Building 9201-1 Site. The proposed approach would involve initial excavation of contaminated soils from the impacted areas of the facility identified in Section 5.3, on-site thermal desorption to physically separate volatile organic compounds (VOCs) from contaminated soil, incineration of VOCs in an afterburner or adsorption by an activated carbon filter, and final disposition of the treated soils by landfilling at a permitted Y-12 facility or use as fill material in the subject site excavation. A graphic illustration of the proposed corrective action for soil is shown in Figure 8-1.

The corrective action approach for soil remediation proposed for the Building 9201-1 Site offers several advantages over the other alternatives evaluated for the Corrective Action Plan. The proposed approach will result in the removal and ultimate destruction of the BTX and TPH soil contamination source at the facility; human health and environmental concerns associated with implementation will be minimal; and the technical requirements associated with it will be manageable. The excavation and thermal desorption approach is also advantageous because the cleanup efficiency of this process is very predictable at 99.9%. Thermal desorption has been proven effective and reliable at similar UST sites.

8.1.2 Soil Remediation System Analysis

8.1.2.1 Removal

Excavation

All contaminated soils identified as in excess of the 250 ppm TDEC Closure Action Level for BTX and 500 ppm for TPH at the Building 9201-1 Site will be removed by excavation for treatment and/or disposal. Delineation of the soil contamination at the site (Section 5.3) indicated the contamination was limited to the former tank pit to the east of Building 9201-1 and directly to the

EXCAVATION PHASE

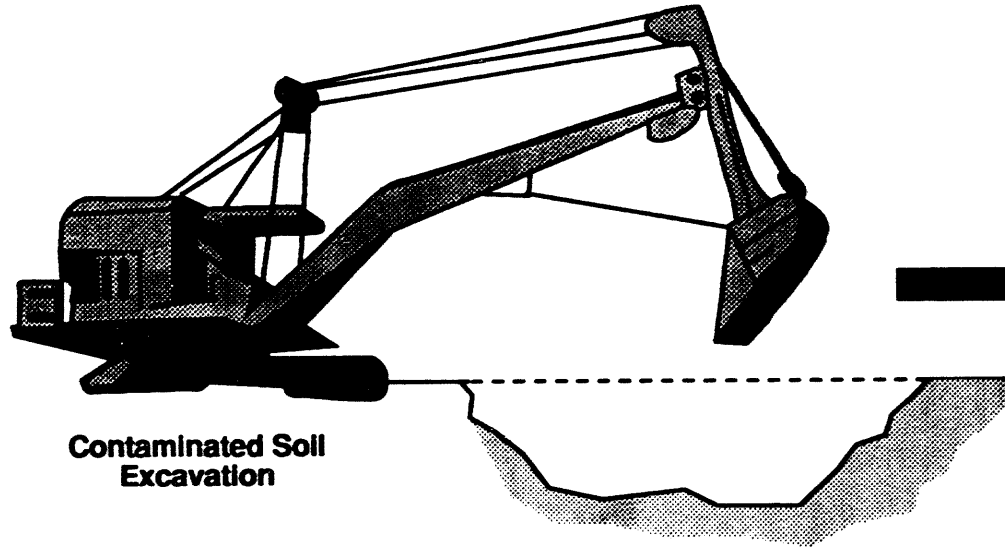

TREATMENT PHASE

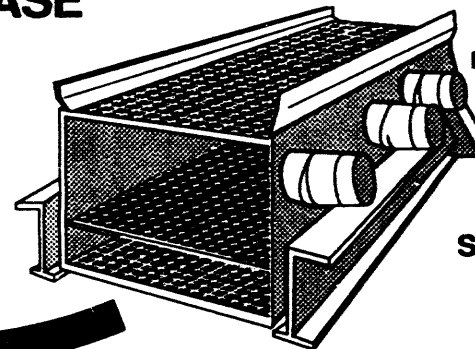
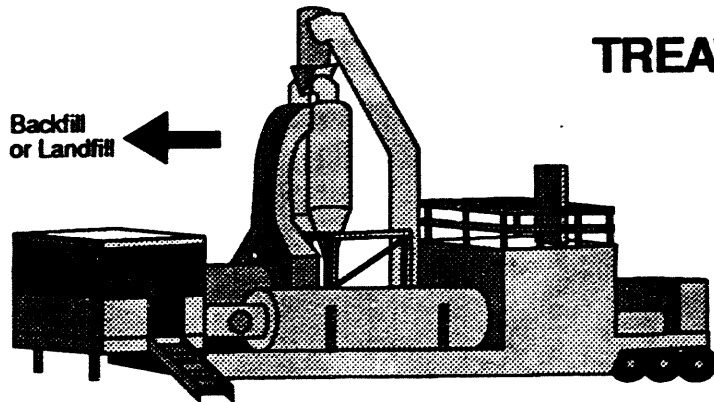

Backfill
or Landfill

Oversized
Material to
Disposal

Backfill
or Landfill

Martin Marietta Energy Systems, Inc.
Environmental Management Department

FIGURE 8-1

Soil Treatment Process Flow

south of the loading dock ramp (Figure 5-10). Excavation beyond the delineated contamination areas may be required if additional contaminated soils are encountered as indicated by soil screening and/or sampling conducted during the excavation activities. Soil excavation should not extend significantly below the local water table since soils in this area would be considered part of the groundwater remediation (see Section 8.2).

Prior to excavation activities, any surface features in the area of proposed excavation will need to be removed. The dismantling, removal, or relocation of any fence, utility, or structure will be under the direction of Energy Systems. Surface control measures will have to be implemented to control surface water runoff and runoff during excavation. Excavation of the contaminated soils will be accomplished using appropriate equipment provided by the Y-12 Plant Maintenance Department or a designated subcontractor. The small amount of contaminated soil could be excavated using a rubber tired backhoe. Within the congested plant environment it is possible that unidentified utility lines pass through the excavation area. Impacted utility lines will be protected during construction. Energy Systems will provide guidance regarding the disposition of utilities in this area and will define those areas to be manually excavated. Figure 2-3 shows the approximate locations of utilities documented near the area of excavation.

Soil samples will be collected during the course of excavation activities within the various areas for the purpose of head space field screening in order to assist with monitoring the progress of contaminated soil removal. Head space screening will be conducted in accordance with Method ESP-303-7, *Soil Gas Sampling* (Martin Marietta Energy Systems, Inc., 1988a). Additionally, visual and odor observations will be made during the excavation process to aid in defining the extent of contamination.

Zone of Influence

Figure 8-2 shows the areal extent of the contaminated soils proposed to undergo remediation. There is a single area of contamination located in the previous tank pit. A buffer of 2.5 ft is assumed to be overexcavated beyond the contaminated area. It is assumed that some noncontaminated material will be excavated and treated with the contaminated soil, since segregation and testing for the relatively small volume at the site would not be cost effective.

The excavation is estimated to encompass an areal extent measuring approximately 20 ft in diameter with an excavation depth of 6 ft. The excavation will continue along the path of the fuel supply

E 59,500

E 59,60

N 29,300

Building
9201-1

0+30
0+25

0+20
0+15

0+10
0+05

Sta. 0+00

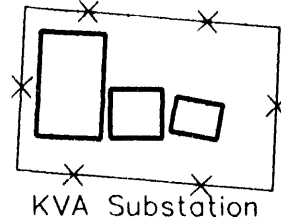

E 59,500

E 59,60

All location information presented in this figure is based upon MMES engineering drawings, results of previous MMES investigations, and/or field determinations of feature and sampling locations. No representation or warranty, expressed or implied, is made as to the accuracy of the information or statements presented in this figure.

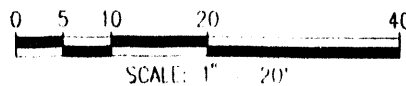

REVISION 1 (7-30-93)
G:\93021R1\DWGS\4318-2

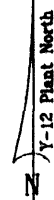

Legend



Soil Contamination >250



Over Excavation Soil

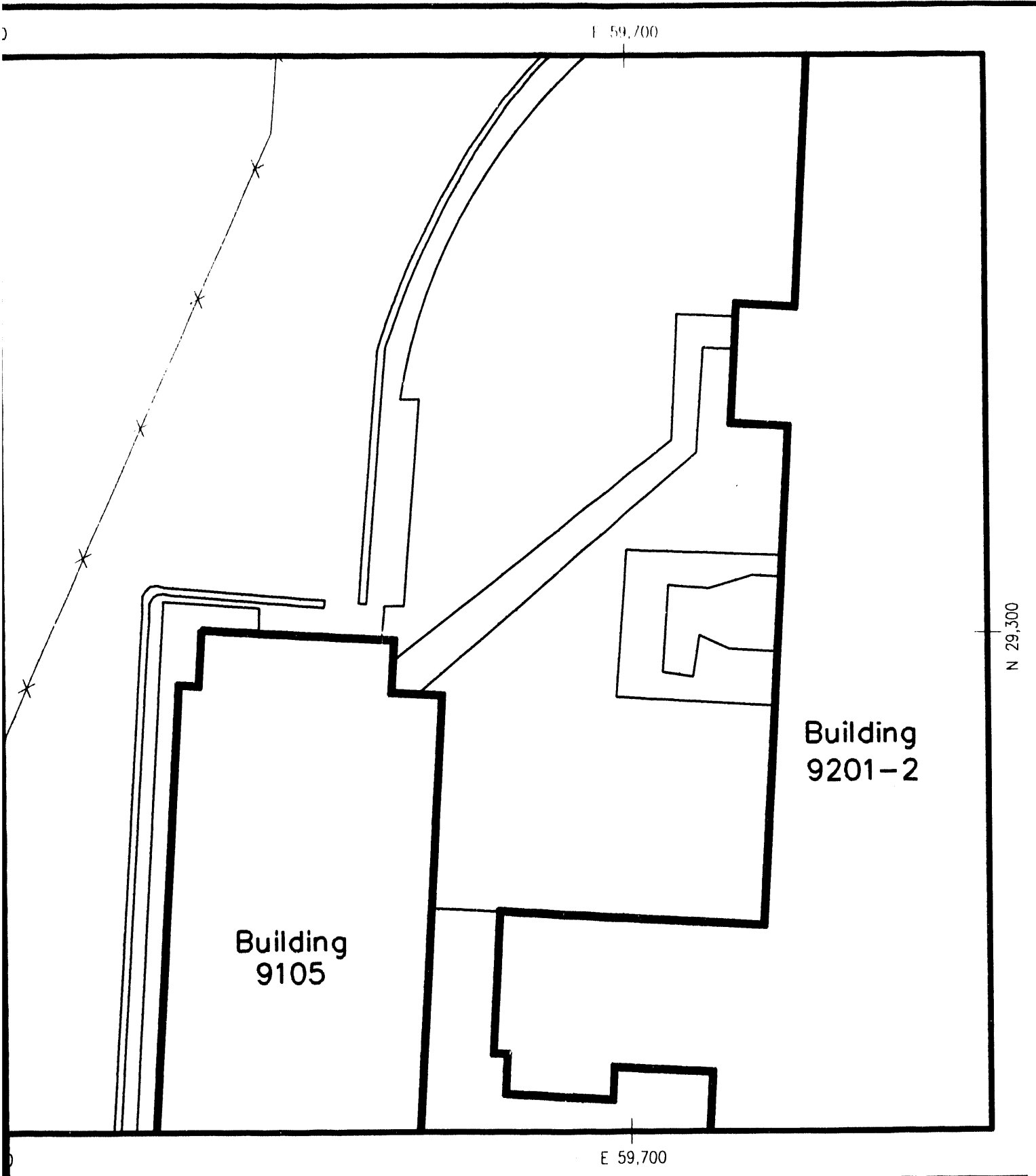

ppm BTX

0+00 Line of Vertical Cross-Section

----- Minimum Area of Excavation

Martin Marietta Energy Systems, Inc.
 Environmental Management Department

FIGURE 8-2

Building 9201-1 Site
Horizontal Zone of Influence Map

lines to Building 9201-1. This excavation is assumed to be 10 to 15 ft wide with an average depth of 6 ft.

The concrete ballast pad for the tank, located at a depth of approximately 6 ft, will be broken into manageable pieces and disposed at the Y-12 landfill. Asphalt or concrete paving in the zone of excavation will be disposed at the landfill as well.

Because of the seasonal variation in the local water table, the depth of excavation is assumed to extend approximately 1 ft below the water table as noted on the cross sections presented in Figure 8-3. Excavation activities are expected to reach bedrock above the groundwater table in some areas. The total excavated soil volume is calculated to be 100 yd³ in place, or 130 yd³ assuming a 30% swell factor. Table 8-1 contains the average end area calculations used to estimate the volume of excavation for the remediation. For estimation purposes the volume is assumed to be entirely soil because the concrete ballast pad represents a volume of less than 1 yd³ of material. The extent of contamination is based on field hydrogeologic information and sample analyses data generated from the previous site investigations; the final soil volume requiring excavation will be dictated by subsurface conditions observed during the course of excavation activities.

Confirmatory Sampling

Upon completion of contaminated soil removal from the impacted areas of the Building 9201-1 Site, field screening and confirmatory soil samples will be collected from the excavation to ensure that this phase of the overall facility remediation is complete. The actual number and locations of the confirmatory samples to be collected will depend on the final areal extent and depth of the excavation and thus will not be determined until all excavation activities are complete. Samples for field screening will be collected at multiple depth intervals between the surface and water table, with an average of one sample for every 100 ft² of excavated surface and in any visibly contaminated areas. These samples will be collected and placed into jars for field head-space analysis using an organic vapor detector (OVD). If samples exceed 250 ppm during field screening, excavation will continue until analyses are below this level. A minimum of 4 confirmatory samples will be collected from the perimeter of the excavation between the surface and water table and sent for laboratory analysis. The actual number of confirmatory samples taken will be sufficient to demonstrate that all soil contaminated above applicable TDEC Closure Action Levels has been removed.

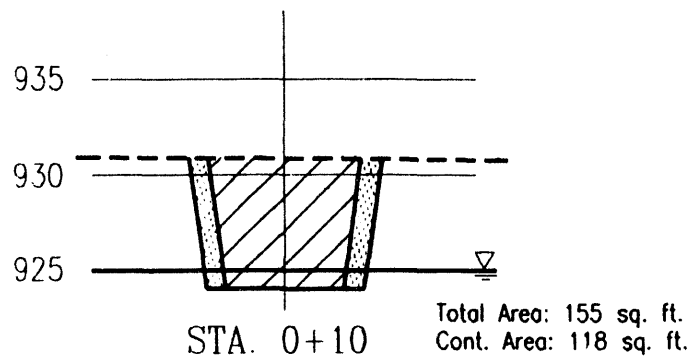
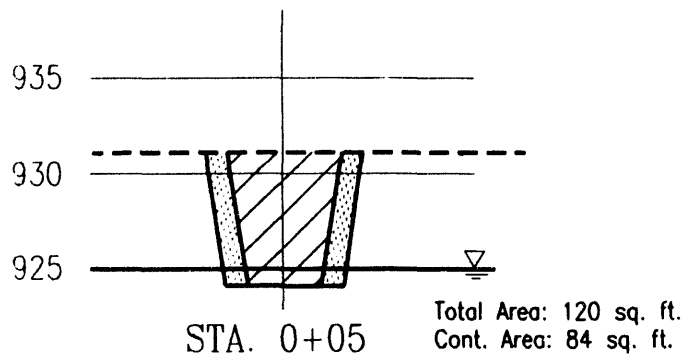
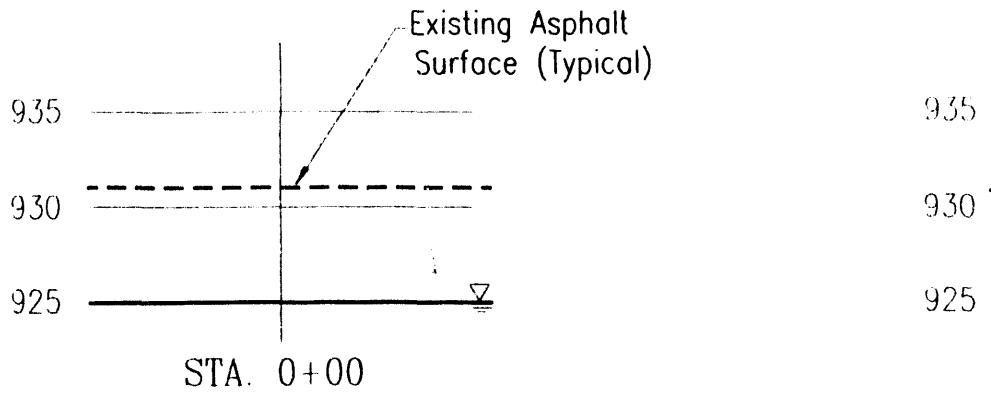

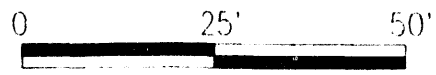

All location information presented in this figure is based upon MMES engineering drawings, results of previous MMES investigations, and/or field determinations of feature and sampling locations. No representation or warranty, expressed or implied, is made as to the accuracy of the information or statements presented in this figure.

Horiz. Scale: 1" = 25'
Vert. Scale: 1" = 10'



Legend

-  Contamination To Be Excavated
-  Non-Contaminated To Be Excavated

G:\93021R1\DWG5\4.518-3

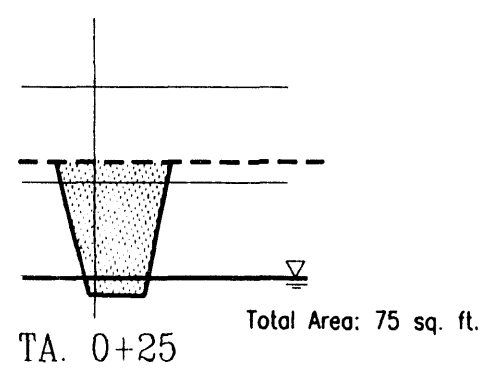
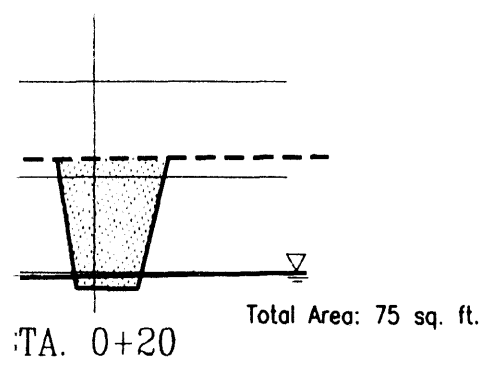
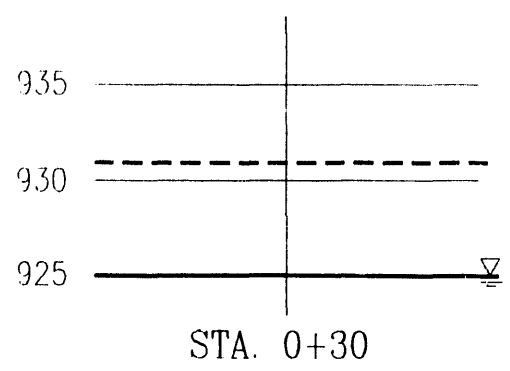
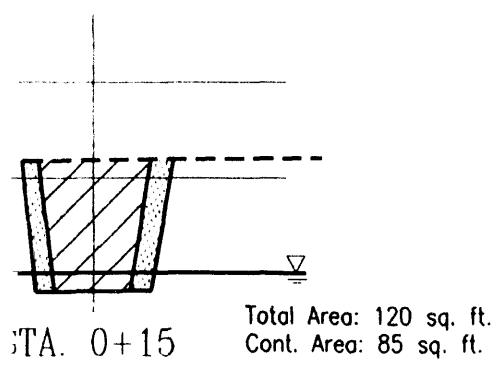

one
& Treated

▽ Water Table

and Soil
& Treated

Martin Marietta Energy Systems, Inc.
Environmental Management Department

FIGURE 8-3
Building 9201-1 Site
Vertical Zone of
Influence Map

**Table 8-1. Volume Calculation for the Building 9201-1 Site Corrective
Action Plan Average End Area Method**

| Station | X-Section Area (ft ²) | Avg. End Area (ft ²) | Distance (ft) | Volume (ft ³) | Volume (yd ³) | 30% Swell Volume (yd ³) |
|-------------------------------|-----------------------------------|----------------------------------|---------------|---------------------------|---------------------------|-------------------------------------|
| 0.0 | 0 | | | | | |
| | | 60 | 5.0 | 300 | 11 | 14 |
| 5.0 | 120 | | | | | |
| | | 138 | 5.0 | 688 | 25 | 33 |
| 10.0 | 155 | | | | | |
| | | 138 | 5.0 | 688 | 25 | 33 |
| 15.0 | 120 | | | | | |
| | | 98 | 5.0 | 488 | 18 | 23 |
| 20.0 | 75 | | | | | |
| | | 75 | 5.0 | 375 | 14 | 18 |
| 25.0 | 75 | | | | | |
| | | 38 | 5.0 | 188 | 7 | 9 |
| 30.0 | 0 | | | | | |
| | | | | ===== | ===== | ===== |
| Total Excavated Volume | | | | 2,727 | 100 | 130 |

All confirmatory soil sampling will be conducted in accordance with Method ESP-303-1, *Soil Sampling with a Spade and Scoop* (Martin Marietta Energy Systems, Inc., 1988a). Sample containers and preservation methods used for all collected samples will follow guidelines presented in Method ESP-701, *Sample Preservation and Container Materials* (Martin Marietta Energy Systems, Inc., 1988a), and sampling equipment decontamination procedures will follow guidelines presented in Method ESP-901, *Equipment Decontamination* (Martin Marietta Energy Systems, Inc., 1988a). Each of the confirmatory soil samples collected will undergo field screening for VOCs and laboratory analysis to determine BTX and TPH-GRO in accordance with the methodologies presented in Table 8-2.

In addition to the confirmatory soil samples, a complete set of QA/QC samples will be collected for this phase of the Building 9201-1 Site remediation. The QA/QC samples to be taken will include duplicate soil samples which are collected along with the confirmatory samples, equipment rinsate samples to be collected on each day that sampling is conducted, and trip blank samples that will accompany each sample cooler transported to the analytical laboratory. The set of duplicate soil samples will represent no less than ten percent (10%) of the total number of confirmatory samples collected. Each of the QA/QC samples will undergo the same laboratory analyses as the confirmatory samples in accordance with the methodologies presented in Table 8-2. All QA/QC activities and documentation will be performed in accordance with the current QA/QC program at the Y-12 Plant.

8.1.2.2 Soil Treatment

The thermal desorption process will provide an ex situ means to physically separate volatile and some semivolatile contaminants from soil. The selected desorption unit will use either indirect or direct heat exchange to vaporize organic contaminants from soil. The thermal desorption process heats the contaminated media between 200° and 600 °F, driving off water and volatile contaminants. Air, combustion gas, or inert gas will serve as the transfer medium for the vaporized components. A baghouse or scrubber will collect the dust from the exhaust which is subsequently joined with the treated waste stream or filtered. Soil will be separated as a clean product and will be used as fill material in the subject site excavation or landfilled at a permitted Y-12 facility.

Table 8-2. Analytical Methods Proposed for Analyses of Remediation Soil and Groundwater Samples Collected at the Building 9201-1 Site

| Contaminant | Analytical Method | Method Number |
|---|--|------------------------------------|
| Confirmatory: Volatile Organic Compounds (BTX) | Gas Chromatography/ Mass Spectroscopy | 8240 ¹ |
| Total Petroleum Hydrocarbons | | |
| TPH-GRO | Gas Chromatography/ Mass Spectroscopy | EPA 8015- Modified ² |
| Post-Treatment: <u>Soil:</u> | | |
| Volatile Organic Compounds (BTX) | Gas Chromatography/ Mass Spectroscopy | 8240 ¹ |
| Total Petroleum Hydrocarbons | | |
| TPH-GRO | Gas Chromatography/ Mass Spectroscopy | EPA 8015- Modified ² |
| <u>Water:</u> | | |
| Volatile Organic Compounds (BTX) | Gas Chromatography/ Mass Spectroscopy | 8240 ¹ |
| Total Petroleum Hydrocarbons | | |
| TPH-GRO | Gas Chromatography/ Mass Spectroscopy | EPA 8015- Modified ² |
| Waste Characterization:⁴ Benzene | Toxicity Characteristic Leaching Procedure–Fourier Transform Infrared Spectrometry | 1311/418.1 ³ |
| Total Petroleum Hydrocarbons | Toxicity Characteristic Leaching Procedure–Fourier Transform Infrared Spectrometry | 1311/418.1 ³ |

¹EPA, November 1986

²TDEC, January 1992

³EPA, March 1983

⁴Waste characterization only to occur if sanitary landfill disposal of soil is required.

Contaminated soil material is removed from the subject site via excavation (as previously discussed) and delivered to the treatment unit. Typically, fill material objects (i.e., stones, brick fragments, etc.) greater than 1.5 inches in size are removed from the contaminated soil material by screening prior to treatment and disposed in a controlled landfill. The soil material is then delivered by gravity to the desorber inlet, or conveyed by augers to a feed hopper.

Thermal desorption treatment units vary greatly in the design of their dryer component. The dryer may be an indirectly fired rotary kiln, a single (or set of) internally heated screw auger(s), or a series of externally heated distillation chambers. The latter design uses annular augers to move the contaminated soil from one volatilization zone to the next. The contaminated soil is placed into contact with the heated dryer surface, and volatile components (including water) are driven off. Vaporized contaminants are removed from the dryer unit using either an inert gas (such as nitrogen) which is injected in a countercurrent sweep stream, or by simply directing the hot gas stream from the dryer.

The primary factors affecting performance in thermal desorption include the actual bed temperature and residence time. Control of these parameters in the desorption unit is provided through use of a series of increasing temperature zones, multiple passes of the medium through the desorber where the operating temperature is sequentially increased, separate compartments where the heat transfer fluid temperature is higher, or sequential processing into higher temperature zones.

Volatiles in the offgas are burned in an afterburner, collected on activated carbon, or recovered in condensation equipment. The carbon filter air pollution control system generates a waste stream that requires additional treatment and/or disposal in a controlled landfill. The selection of the gas treatment system will be based on an evaluation of the concentrations of contaminants, cleanup standards, and the economics of the offgas treatment system(s) employed.

Regulatory and administrative controls will be taken into consideration with the implementation of this process. An evaluation of potential permit requirements and environmental impacts will be necessary. There are numerous vendors available with the necessary equipment and skilled workers to implement this technology. A mobile unit would be set up onsite. There would be no long-term management of residual contamination and/or untreated waste due to the removal of the contaminants and subsequent disposal. Operating costs will be moderate to high ranging from \$30-\$100/yd³.

The thermal desorption unit will be staged at an appropriate location within the Y-12 Plant site. A minimum area of 150' × 130' will be necessary to accommodate the equipment. A suitable laydown area will be required to stockpile soil before and after treatment. The laydown area will be used to stockpile contaminated soil upon its excavation from the subject site. Four to five operators will be required to operate the equipment which requires 480 volts at 600 amps of operating power, a substantial amount of propane fuel, and 20 to 100 gpm of water to re-hydrate and cool soil after desorption.

The excavation equipment may be operated simultaneously with the thermal desorption treatment unit, or excavation activities may be conducted prior to treatment activities if procurement of the treatment unit is not complete at the beginning of soil excavation. Operated simultaneously, an excavation rate of approximately 20 yd³/hr would maximize the treatment production rate. This production rate is commensurate with the treatment rate of typical thermal desorption units. If excavation precedes treatment, soil material will be stockpiled during the course of excavation activities. Stockpiled material would be placed on plastic sheeting and covered to ensure that further contamination of the Building 9201-1 Site does not occur. Stockpiling of soil material would allow excavation activities to occur continuously through completion. A front end loader would then be used to load contaminated soils into the treatment unit from the soil stockpiles.

Post-Treatment Sampling

During the course of the thermal desorption soil treatment phase of the corrective action, post-treatment soil samples will be collected for laboratory analysis. These samples will be used to monitor the effectiveness of petroleum contaminant removal within the thermal desorption unit. Remediation of the soils will be considered complete when the concentrations of benzene and TPH have been reduced to levels less than or equal to 10.0 ppm and 100.0 ppm, respectively.

Samples will be collected from soil stockpiles created as treated soil material exits the thermal desorption unit. Initially, the total volume of each stockpile (in cubic yards) will be determined. The total volume number will then be divided by fifteen and the resulting number will be multiplied by two. This calculated value will represent the number of soil samples that must be collected from a given stockpile for field screening analysis. These samples will be collected from points that are evenly distributed throughout the entire volume of the soil, and will be representative of the total soil volume rather than the total area occupied by a given soil stockpile. The collected samples will undergo field head space screening using an OVD or field gas chromatograph. Based on the results of the field screening, a minimum of 2 of the collected samples exhibiting the highest field

screening readings will be submitted for laboratory analyses. In the event that the volume of a treated soil stockpile exceeds 240 yd³, additional samples will be submitted for laboratory analyses in accordance with the requirements of the TDEC Technical Guidance Document - 005.

All post-treatment soil sampling will be conducted in accordance with Method ESP-303-1, *Soil Sampling with a Spade and Scoop*, or with a hand auger in accordance with Method ESP-303-2, *Soil Sampling with an Auger*. Samples collected will be handled and preserved in accordance with Methods ESP-701, *Sample Preservation and Container Materials* and ESP-800, *Packaging Environmental Samples for Transportation*. All of the equipment used for sample collection will be decontaminated in accordance with Method ESP-900, *Cleaning and Decontaminating Sample Containers and Sampling Devices*.

In addition to the post-treatment soil samples, a complete set of quality assurance/quality control (QA/QC) samples will also be collected for the post-treatment phase of remediation. The QA/QC samples will include equipment rinsate samples to be collected on each day that stockpile sampling is conducted, and trip blank samples that will accompany each sample cooler transported to the analytical laboratory. A set of duplicate soil samples will also be collected with the post-treatment soil samples. The set of duplicate samples will represent no less than ten percent (10%) of the total number of post-treatment samples collected. Each of the post-treatment and QA/QC soil samples collected and submitted to the laboratory will undergo analysis to determine content of benzene and TPH in accordance with the methods presented in Table 8-2.

8.1.2.3 Disposal of Soil

Upon receipt of the analytical results for the treated soil stockpiles, this material will be transported for final disposal back into the excavation area, at a Y-12 Plant landfill, or another similar facility provided that the material meets applicable TDEC requirements for such disposal. In the event that the analytical results for any given soil stockpile indicate that it contains contaminant levels in excess of TDEC requirements for uncontrolled landfill disposal, the material will be re-introduced into the thermal desorption unit and treated for a second time. Treatment will continue until the contaminant levels within the material are reduced such that the desired disposal option can occur as documented by soil stockpile sampling.

It is anticipated that near-surface soil and gravel overburden at the Building 9201-1 Site will contain contaminant levels well below TDEC Closure Action Levels. This material will be stockpiled near the site excavations upon removal and sampled in the same manner as that

described for the treated soil stockpiles in Section 8.1.2.2 or retained for controlled disposal. Based on the analytical results for the overburden material, it will either be returned to the excavation areas as backfill, disposed of at an appropriate landfill, or sent to the thermal desorption unit for treatment prior to disposal.

8.2 Groundwater Corrective Action

8.2.1 General Description of Groundwater Corrective Action

Based on an evaluation of all criteria associated with the corrective action options discussed in Section 7.2, a combination of process options is proposed for remediation of petroleum-contaminated groundwater at the Building 9201-1 Site. The proposed approach would involve initial extraction of the contaminated groundwater using conventional recovery wells, treatment at one of the Y-12 Plant wastewater treatment facilities, and final discharge in compliance with the NPDES permit for the Y-12 Plant, as shown in Figure 8-4. The Y-12 NPDES permit allows for the treatment of contaminated groundwater at the wastewater treatment facilities. The first step of this process involves the extraction of the contaminated groundwater using two recovery wells to be installed at the site. The groundwater will be pumped into a tanker truck and hauled to one of the Y-12 wastewater treatment facilities within the Waste Management organization (see Figure 8-5). After treatment, the effluent will be released at an NPDES-permitted outfall.

The corrective action approach for groundwater remediation proposed for the Building 9201-1 Site offers several advantages over the other actions evaluated for the original CAP. The proposed approach will result in the efficient removal of the contaminated groundwater, equipment needs are minimal and readily available, no treatability study is required, human health and environmental impacts associated with implementation will be minimal, the approach will be low-cost, and the technical requirements associated with it will be manageable.

8.2.2 Groundwater Remediation System Analysis

8.2.2.1 Removal

Groundwater Monitoring

The monitoring of the migration and cleanup progress of the contaminated groundwater plume will be conducted using monitoring wells. In addition to the existing monitoring wells, a minimum of

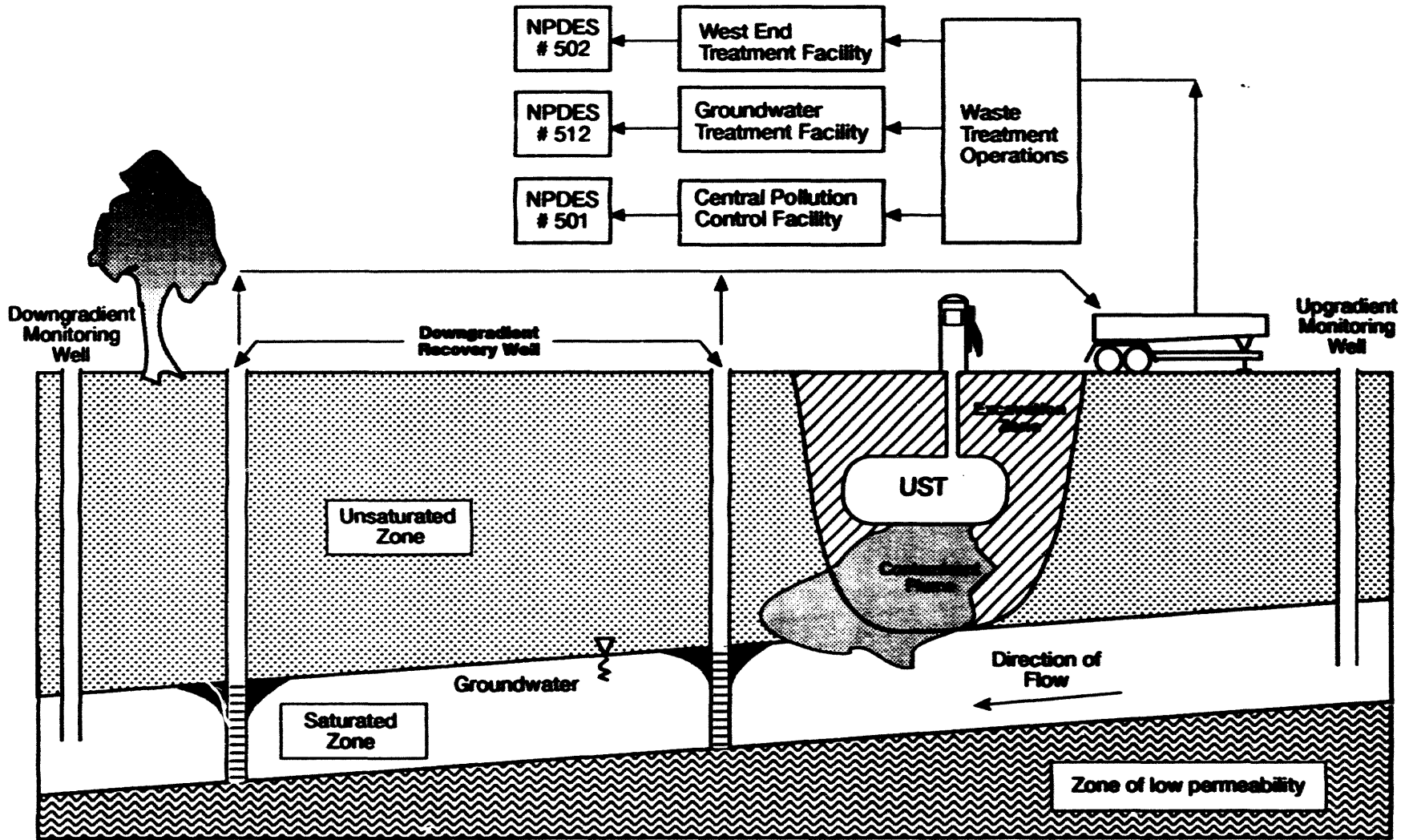

Martin Marietta Energy Systems, Inc.
Environmental Management Department

FIGURE 8-4
Groundwater Treatment Process Flow

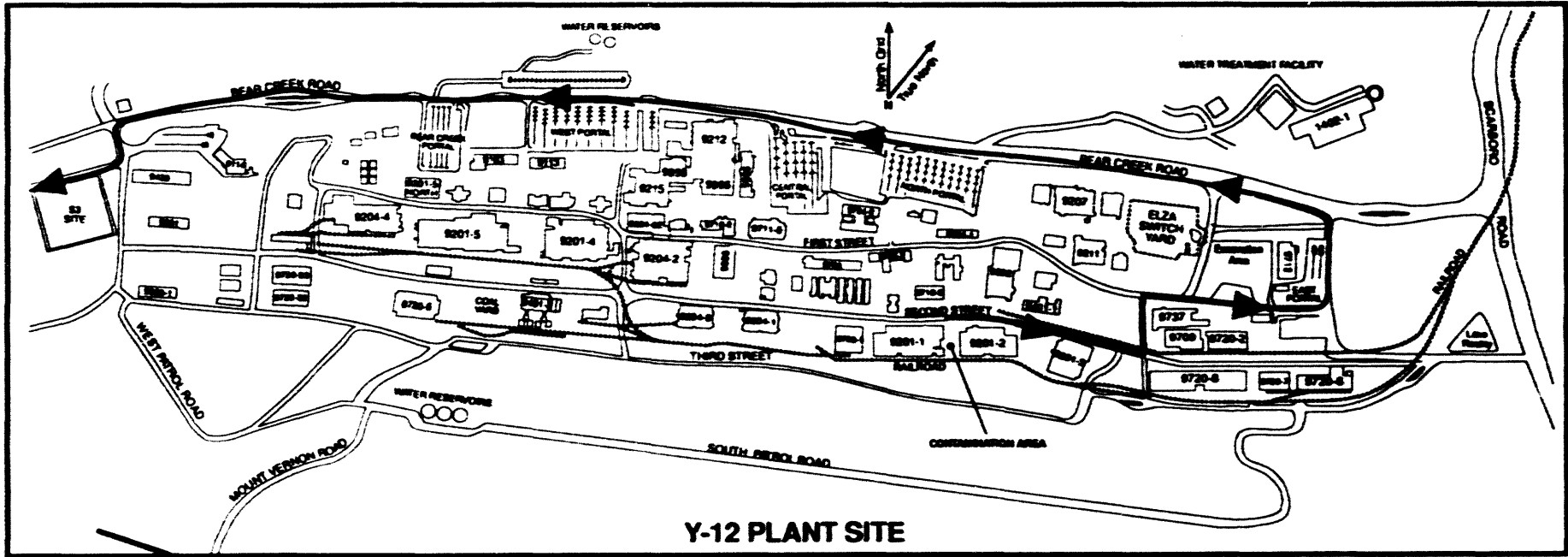

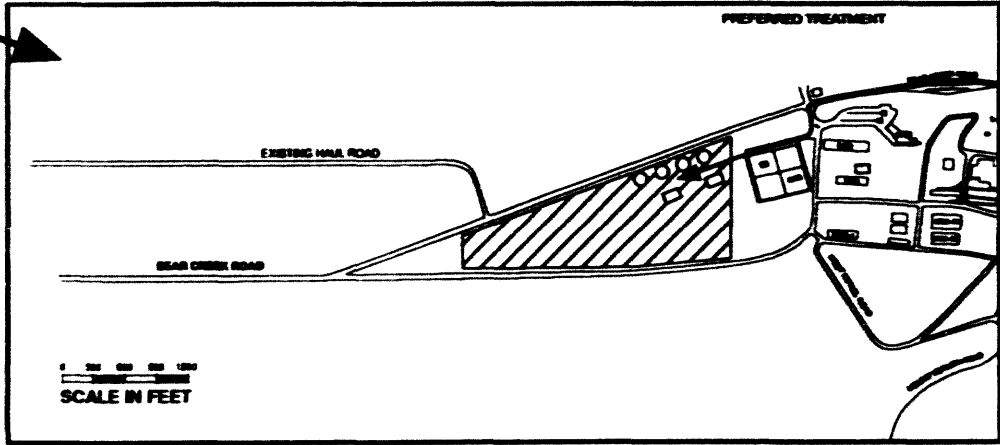

Y-12 PLANT SITE



All location information presented in this figure is based upon MMES engineering drawings, results of previous MMES investigations, and/or field determinations of feature and sampling locations. No representations or warranty, expressed or implied, is made as to the accuracy of the information or statements presented in this figure.

LEGEND

-  TREATMENT SITE
-  EXCAVATION AREA
-  GROUNDWATER HAUL ROUTE

0 200 400 600 800 1000
SCALE IN FEET

Martin Marietta Energy Systems, Inc.
Environmental Management Department
FIGURE 8-5
Groundwater Treatment Facility Location

three additional wells should be placed downgradient of the suspected plume, as shown in Figure 8-6. In the event that any of these downgradient wells indicate groundwater contamination in excess of TDEC Closure Action Levels, an evaluation will be conducted to redefine the contaminant plume, and additional monitoring wells will be placed downgradient of the redefined plume. The installation of additional monitoring wells will be coordinated with the Y-12 Plant groundwater protection program. Reiteration of this process should continue until any extension of the contaminant plume is fully defined.

Extraction

All contaminated groundwater identified in excess of the 1.0 ppm TDEC Closure Action Level for TPH and/or 0.070 ppm for benzene at the Building 9201-1 Site will be extracted using recovery wells prior to treatment and release to surface waters. The groundwater contaminant plume, as depicted in Figure 8-6, begins east of Building 9201-1 and south of the loading dock and extends south and east.

Two extraction wells will be placed within the area of the contaminant plume, approximately 50 ft apart as shown in Figure 8-6. The exact number and location of these wells will be determined in the final design, and existing wells may be used in place of or along with the extraction wells for groundwater recovery. It is recommended that the depth of the wells extend down to weathered bedrock and be screened from the total depth to 1 ft above the seasonal high water table. The recovery wells should be a minimum of 4 inches in diameter, sand packed at the screened interval, and plugged with bentonite and cement.

Groundwater extracted from the recovery wells will be filtered to remove sediment and sludge using a mobile filtration unit. All filtered particulates will be transported to a permitted Y-12 facility for disposal. The extracted groundwater will be pumped into a tanker truck onsite, and at regular intervals, the groundwater will be hauled to the designated WTO treatment facility.

Zone of Influence

The areal distribution of the contaminated groundwater plume is shown in Figure 8-7 and vertical extent is shown in Figure 8-8. The surface area of the plume is approximately 2,300 ft². Assuming 10% effective soil porosity and an 8-ft vertical extent of contamination below the water table, the contaminated groundwater volume is estimated to be approximately 13,760 gallons. This

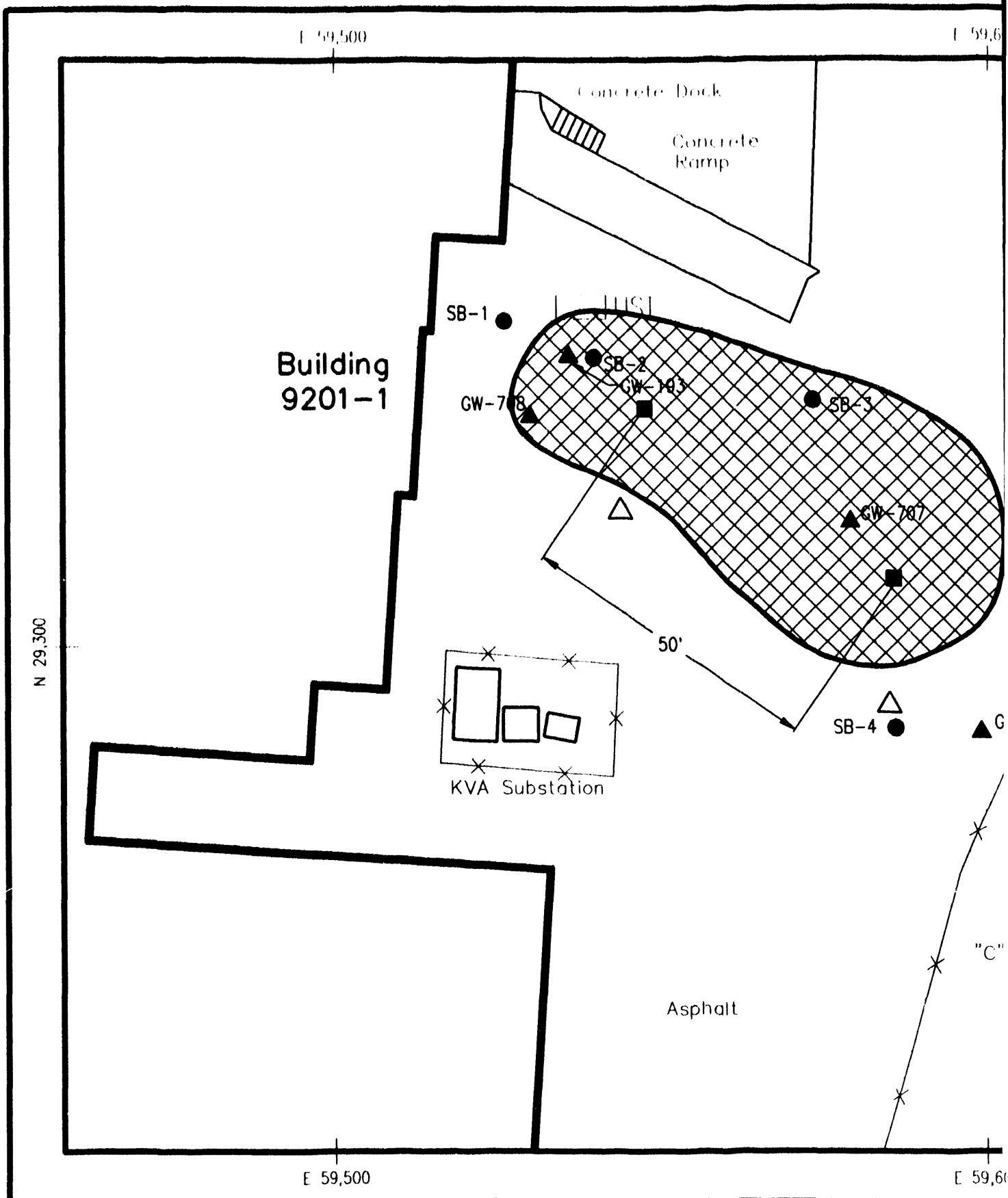

All location information presented in this figure is based upon MMES engineering drawings, results of previous MMES investigations, and/or field determinations of feature and sampling locations. No representation or warranty, expressed or implied, is made as to the accuracy of the information or statements presented in this figure.

REVISION 1 (7-30-93)
 G:\93021R1\DWG\4318-6

| Legend | |
|--------|--|
| ● SB-1 | Soil Sampling Borehole Locations |
| ▨ | Groundwater Contamination >0.0 ppm Benzene |

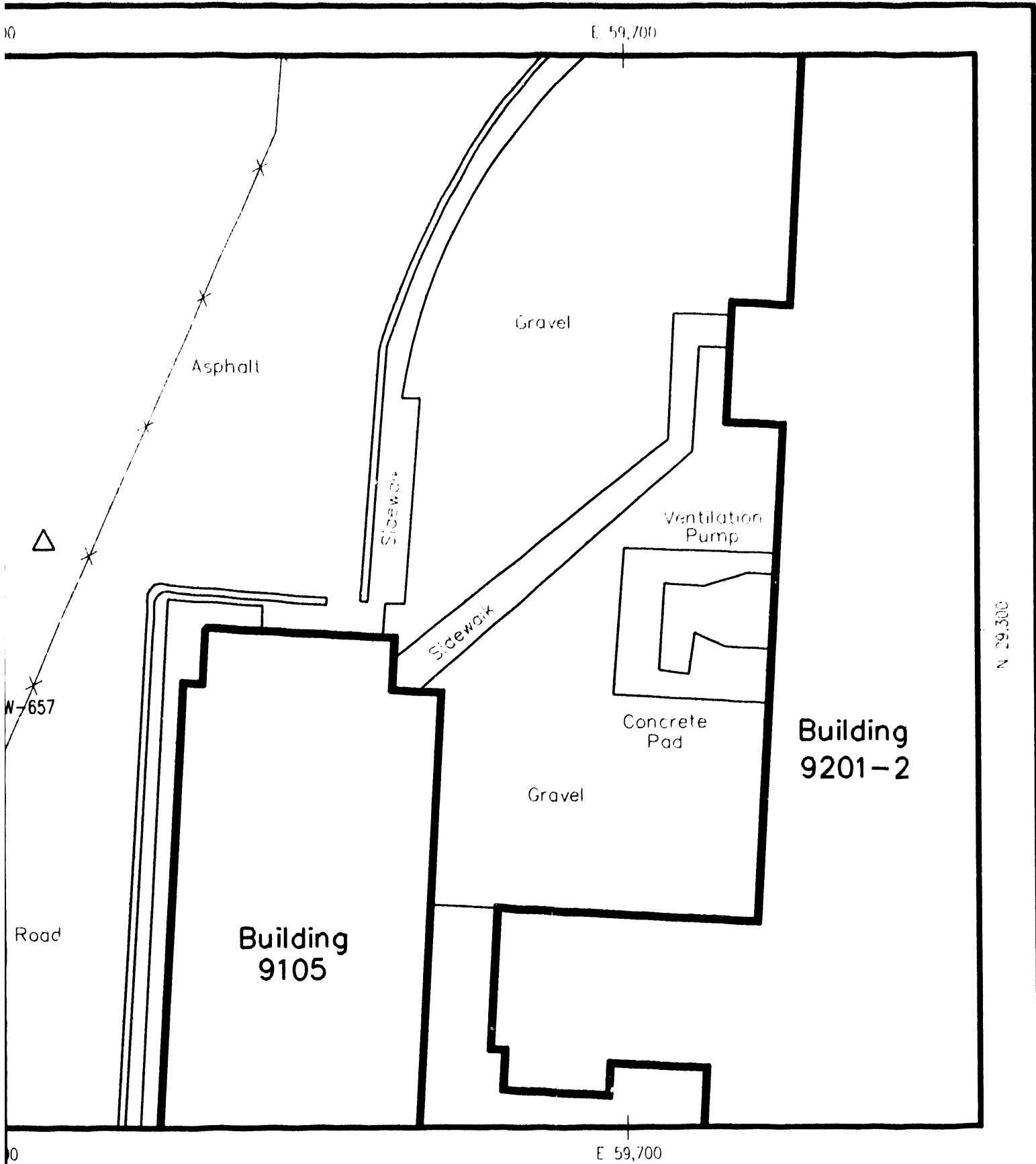

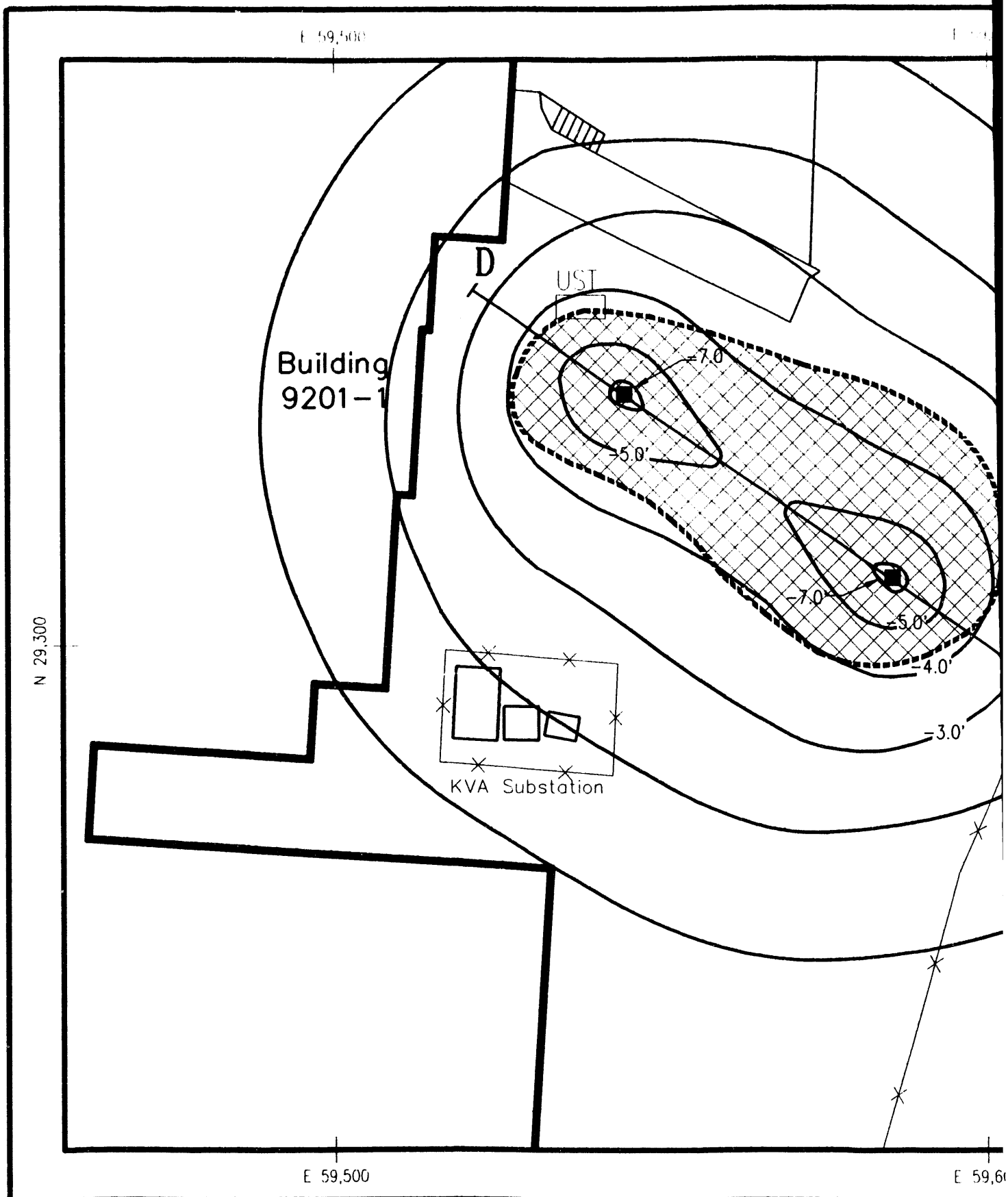

| | | |
|---|--------|---------------------------------------|
| ▲ | GW-193 | Groundwater Monitoring Well Locations |
| ■ | | Proposed Extraction Well Locations |
| △ | | Proposed Monitoring Well Locations |

Martin Marietta Energy Systems, Inc.
 Environmental Management Department
FIGURE 8-6
Building 9201-1 Site
Zone of Ground Water
Contamination of Benzene & TPH

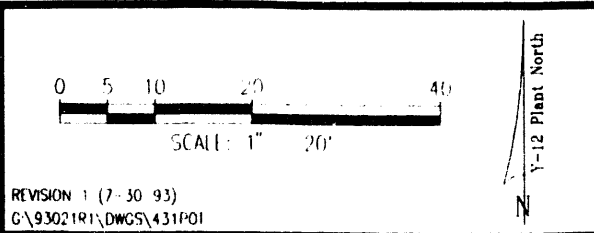

All location information presented in this figure is based upon MMES engineering drawings, results of previous MMES investigations, and/or field determinations of feature and sampling locations. No representation or warranty, expressed or implied, is made as to the accuracy of the information or statements presented in this figure.



| Legend | |
|---|------------------------------------|
|  | Proposed Extraction Well Locations |
|  | Groundwater Contam >0.0ppm Benzene |

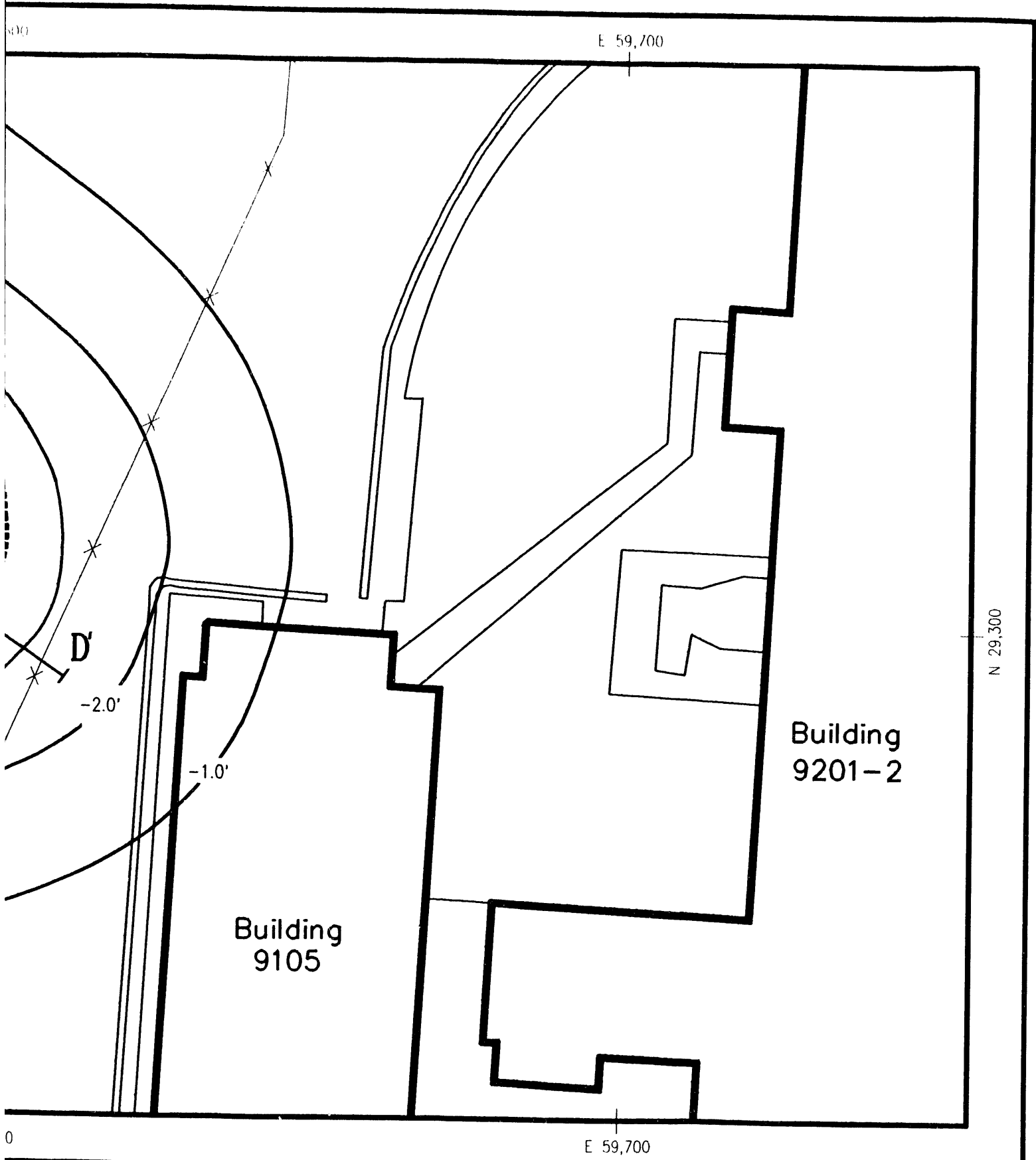

— Potentiometric Surface

Concentration
 > 1.0ppm TPH

Martin Marietta Energy Systems, Inc.
 Environmental Management Department

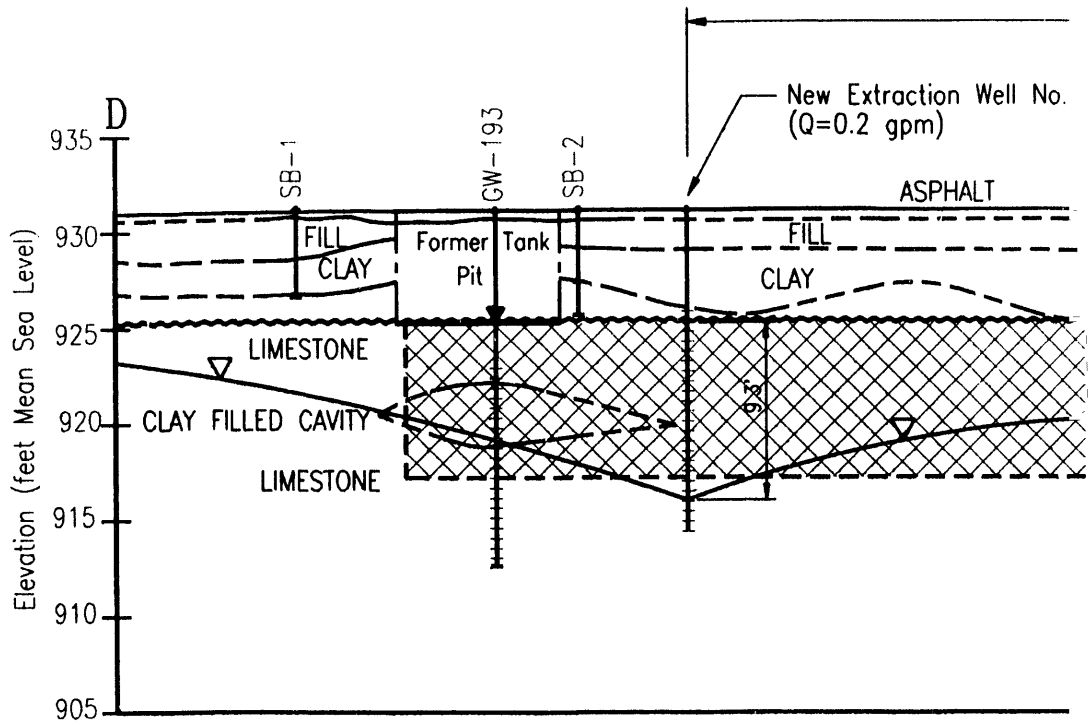

FIGURE 8-7
Potentiometric Surface
at the Building 9201-1 Site

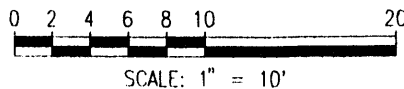

All location information presented in this figure is based upon MMES engineering drawings, results of previous MMES investigations, and/or field determinations of feature and sampling locations. No representation or warranty, expressed or implied, is made as to the accuracy of the information or statements presented in this figure.



LEGEND

-  Groundwa
>0.07 pp
-  Inferred Y
-  Former T
Pit Bound

REVISION 1 (8-2-93)
C:\93021R1\DWGS\4318-8

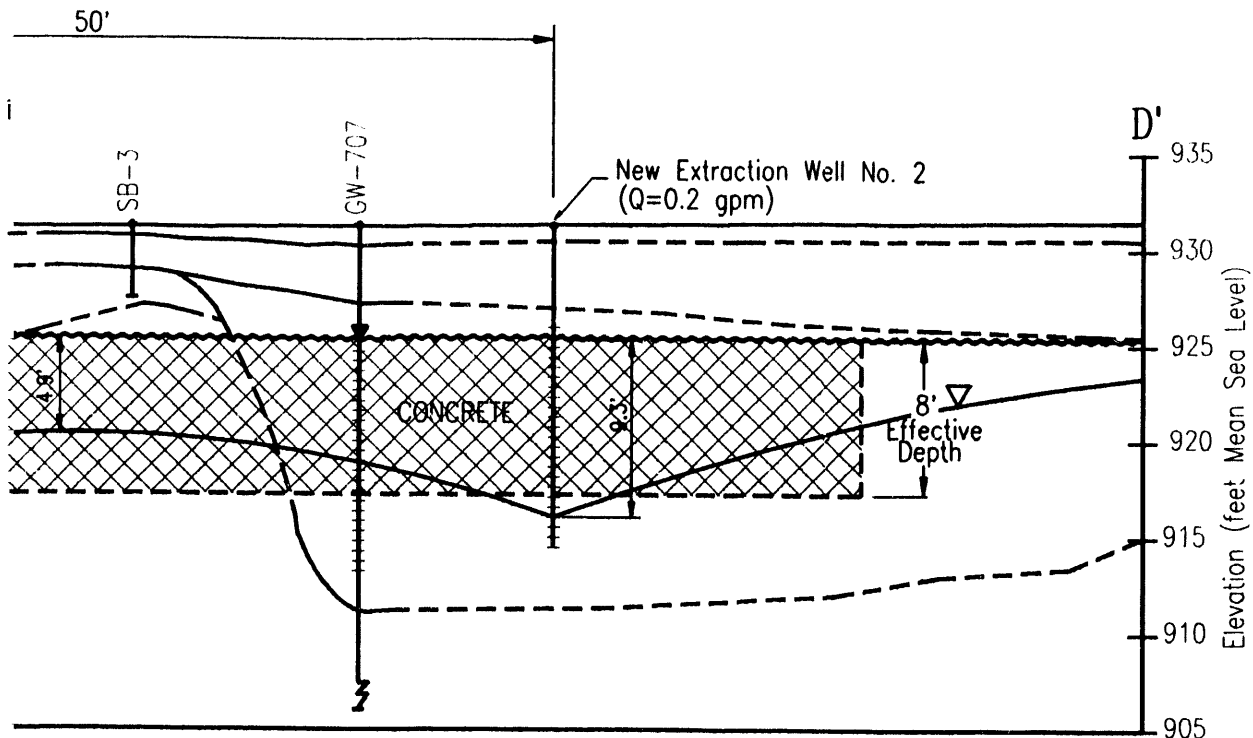

or Contamination
 Benzene and >1.0 ppm TPH
 ater Table During Drawdown
 nk
 ries

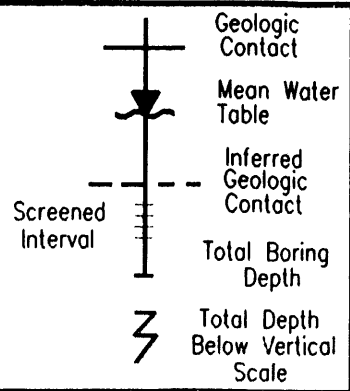

Martin Marietta Energy Systems, Inc.
 Environmental Management Department

FIGURE 8-8
Building 9201-1 Site Vertical
Extent of Groundwater Contamination
And 45-Day Drawdown
Along Cross-Section D-D'

provides a conservative estimate, as it assumes aquifer homogeneity and does not consider the reduction in groundwater volume due to the probable presence of concrete or other low-permeability materials within the aquifer. It is anticipated that an equivalent of ten times this volume, or 137,600 gallons, will be extracted in order to effectively flush the partitioned contaminants from the saturated soils.

The potentiometric surface of the affected groundwater resulting from the proposed corrective action was determined using the Jacob Straight-Line Method (Freeze and Cherry, 1979) and is depicted in Figure 8-7. To determine the drawdown for an assumed pump rate over a period of time at each of the proposed extraction wells, an effective hydraulic conductivity of 1.68×10^{-4} cm/sec (3.56 gpd/ft²) was calculated by averaging the hydraulic conductivities of wells GW-707 and GW-193 (see Appendix H). Storativity is equivalent to specific yield in an unconfined aquifer and a value of 0.03 for limestone was used (Freeze and Cherry, 1979). Due to the relatively low conductivity, an optimal pump rate of 0.2 gpm per well was assumed and a cone of depression was calculated. Figure 8-8 reflects this drawdown, which was conducted over a 45-day period. Assuming a 15-day period of no pumping in which the water table partially recovers, 12,960 gallons can be extracted per month. At this withdrawal rate, the pump-and-haul corrective action will require approximately 11 months to complete. It should be noted, however, that past drilling experience in this unit indicates that appreciably higher withdrawal rates may be encountered. In addition, a more effective pump rate may be obtained in the final design by intermittent pumping between extraction wells. Determination of actual pump rates will be made in the field.

Solution of the Jacob equation and the predicted area of influence of the remediation technique is based on several assumptions including those mentioned above. The model assumes that the aquifer conditions reflect an extensive, horizontal, homogeneous, unconfined, isotropic aquifer with fully penetrating wells. Components of flow along fractures, interference of groundwater flow patterns by man-made subsurface features, and other factors may affect the final zone of influence. However, the model given above uses the most stringent conductivity values obtained for the area, and therefore, gives the most conservative estimate of area of influence.

8.2.2.2 Groundwater Treatment and Disposal

Groundwater will be extracted from the recovery wells and will be filtered to remove sediment and sludge using a mobile filtration unit. The groundwater will then be pumped into a tanker truck and

hauled to the treatment facility. The tanker will haul the groundwater to the designated treatment facility according to the route depicted in Figure 8-5.

The water will be sampled prior to treatment and, based on this analysis, the water will be compared to the Waste Acceptance Guidelines for the three treatment facilities proposed for receipt of the contaminated groundwater from the Building 9201-1 Site. The proposed treatment facilities are the WETF, the GWTF, and the CPCF. Wastes treated at the WETF, GWTF, and CPCF include nitrate bearing aqueous waste, volatile and non-volatile organic compounds and iron, and mop water and non-nitrate bearing waste streams, respectively. After treatment, the effluent will be released to East Fork Poplar Creek at NPDES outfall #502 for WETF, NPDES outfall #512 for GWTF, or NPDES outfall #501 for CPCF.

Progress/Post-Treatment Sampling

During the course of the pump-and-haul groundwater remediation phase of the Building 9201-1 Site corrective action, progress and post-treatment groundwater samples will be collected for laboratory analysis. These samples will be used to monitor the progress of petroleum contaminant reduction within the area of affected groundwater and to determine the point at which treatment of the contaminated media is complete. Remediation of the groundwater will be considered complete when the concentrations of benzene and TPH have been reduced to levels less than or equal to 0.07 ppm and 1.0 ppm, respectively, for four consecutive quarters. In addition to the progress and post-treatment samples and prior to initiation of groundwater remediation, baseline groundwater samples will be collected in order to establish pre-remediation groundwater contamination levels.

All groundwater sampling will be conducted in accordance with Y-12 Plant Standard Operating Procedure #8102.R4, *Groundwater Sampling*. Samples collected will be handled and preserved in accordance with Methods ESP-701, *Sample Preservation and Container Materials*, and ESP-800, *Packaging Environmental Samples for Transportation*. All of the equipment used for sample collection will be decontaminated in accordance with Method ESP-900, *Cleaning and Decontaminating Sample Containers and Sampling Devices*.

Sets of groundwater progress samples will be collected from each monitoring and recovery well on a monthly basis for the first three months after implementation of groundwater remediation, and on a quarterly basis thereafter. Upon receipt of three consecutive quarters of groundwater sample results that indicate contaminant levels below required TDEC remediation levels, a final set of post-treatment groundwater samples will be collected during the fourth quarter.

In addition to the various types of groundwater samples, a complete set of QA/QC samples will also be collected during groundwater remediation at the Building 9201-1 Site. The QA/QC samples will include equipment rinsate samples to be collected for each groundwater sampling event and trip blank samples that will accompany each sample cooler transported to the analytical laboratory. Sets of duplicate groundwater samples will also be collected during the course of groundwater remediation activities. These samples will represent no less than ten percent (10%) of the total number of groundwater samples collected during remediation. Each of the groundwater and QA/QC samples collected will undergo laboratory analysis to determine concentrations of benzene and TPH in accordance with the methodologies presented in Table 8-2.

8.2.2.3 Discharge/Disposal of Groundwater

Discharge of the treated groundwater from the Building 9201-1 Site will be by release to the surface water system of the Y-12 Plant. All discharges from the Y-12 Plant are monitored by existing NPDES monitoring stations. Additional NPDES and TDEC permitting is not anticipated to be required for this discharge.

9.0 PROPOSED IMPLEMENTATION SCHEDULE

This section presents the schedule proposed for the activities and reporting associated with implementation of the chosen corrective actions for the Building 9201-1 Site. Removal of affected media is scheduled to begin within 60 days of TDEC approval of the site Corrective Action Plan. The proposed schedule for corrective actions at the Building 9201-1 Site is as follows:

| <u>Activity</u> | <u>Target Date</u> |
|---|--|
| Issue CAP | July 1992 |
| Issue Revised CAP Figures and Sections | September 1993 |
| TDEC Approval of CAP |pending.... |
| Complete Installation of Additional Site Monitoring Wells, and Sampling & Analyses of Site Monitoring Wells | Within 45 days of CAP approval |
| Issue Baseline Report | Within 45 days of receipt of the analyses results for monitoring well sampling |
| Begin Installation of Groundwater Recovery System | Within 30 days of Baseline Report issuance |
| Begin Operation of Groundwater Recovery System and Treatment of Contaminated Groundwater | Within 60 days of Baseline Report issuance |
| Begin Soil Excavation | Within 60 days of CAP approval |
| Issue First Monthly Report on Progress and Field Sample Analyses | Within 45 days of start of soil excavation |
| Begin Thermal Desorption Treatment of Contaminated Soils | Within 60 days of contract award |
| Issue Second and Third Monthly Reports on Progress and Field Sample Analyses | Within 30 days and 60 days, respectively, of the first monthly report |
| Issue Quarterly Reports on Progress and Field/Treatment Sample Analyses | Within 90 days of the third monthly report and every 90 days for subsequent quarterly reporting periods for as long as remediation activities are in progress |
| Issue Final Corrective Action Report | Within 90 days of the completion of all soil and groundwater remediation activities, and receipt of four consecutive quarters of groundwater sampling results below TDEC Closure Action Levels |

10.0 MONITORING AND REPORTING

After the corrective action system has become operational, monitoring will be conducted to document effectiveness of the treatment system.

10.1 Baseline Report

Prior to full system startup, a baseline report for corrective actions to be implemented at the Building 9201-1 Site will be completed and sent to the appropriate TDEC offices, detailing applicable information required by the Corrective Action Plan Guidelines (TDEC, 1992). This report will contain, at a minimum, analytical results for groundwater samples collected to establish pre-remediation contamination levels, any additional information concerning the design of the groundwater recovery system generated from the results of the baseline groundwater sampling, and a zone of influence potentiometric map.

10.2 Monthly and Quarterly Reports

Monthly progress reports for the first three (3) month period during which corrective actions are implemented at the Building 9201-1 Site will be completed and sent to the appropriate TDEC offices, detailing applicable information required by the Corrective Action Plan Guidelines. These reports will be submitted by the fifteenth (15th) day of each subsequent month within the initial three month reporting period.

Quarterly progress reports regarding corrective actions will be submitted after the initial three month reporting period. These reports will be submitted within fifteen (15) days of the end of each reporting quarter and will continue for the duration of the corrective action process. At a minimum, the monthly and quarterly reports will contain the following information:

- General description of the progress or completion of corrective action activities to date.
- Analytical results for field screening and confirmatory soil samples collected during the course of excavation activities.
- Analytical results for groundwater samples collected during the reporting period.

- **Analytical results for post-treatment soil samples collected during the course of thermal desorption treatment.**
- **General description of any problems encountered with the corrective action systems since the previous reporting period and the actions undertaken to resolve these problems.**

10.3 Corrective Action Report

A Corrective Action Report for the Building 9201-1 Site will be prepared upon completion of all remediation activities and receipt of four consecutive quarters of groundwater sampling results below TDEC Closure Action Levels. This report will include the following information:

- **Description of excavation activities conducted at the site and confirmatory soil sampling performed within excavation pits.**
- **Description of on the thermal desorption treatment system used for remediation of contaminated site soil.**
- **Description of the operational history of the groundwater recovery system used for remediation at the site.**
- **Description of all disposal actions regarding treated soil and groundwater.**
- **Analytical results reported for all types of soil and groundwater samples collected during the course of remediation.**
- **Conclusions concerning the effectiveness of all soil and groundwater corrective actions implemented at the site.**

DATE

FILMED

2 / 24 / 94

END