

NYO-3829-88
February 1972GAUGE INVARIANCE AND WARD IDENTITIES IN A
MASSIVE VECTOR MESON MODEL

MASTER

J. H. Lowenstein*

Department of Physics
University of Pittsburgh
Pittsburgh, Pennsylvania 15213

B. Schroer

✓ Institut für Theoretische Physik
Freie Universität Berlin
Berlin, Germany

ABSTRACT

Normal product techniques are applied to the study of gauge invariance in a massive vector meson model in renormalized perturbation theory. Composite fields are defined which are invariant under a one-parametric family of covariant gauge transformations. Ward identities are derived for Green's functions involving an arbitrary number of vector and axial-vector currents. The lack of lowest order radiative corrections to the triangle anomaly of the axial-vector Ward identity is verified using BPHZ methods.

*Supported in part by the U. S. Atomic Energy Commission under Contract No. AT-(30-1)-3829. Research conducted in part while a guest of the Aussenkommission der Freien Universität Berlin.

NOTICE

This report was prepared as an account of work sponsored by the United States Government. Neither the United States nor the United States Atomic Energy Commission, nor any of their employees, nor any of their contractors, subcontractors, or their employees, makes any warranty, express or implied, or assumes any legal liability or responsibility for the accuracy, completeness or usefulness of any information, apparatus, product or process disclosed, or represents that its use would not infringe privately owned rights.

DISTRIBUTION OF THIS DOCUMENT IS UNLIMITED

Case

DISCLAIMER

This report was prepared as an account of work sponsored by an agency of the United States Government. Neither the United States Government nor any agency thereof, nor any of their employees, makes any warranty, express or implied, or assumes any legal liability or responsibility for the accuracy, completeness, or usefulness of any information, apparatus, product, or process disclosed, or represents that its use would not infringe privately owned rights. Reference herein to any specific commercial product, process, or service by trade name, trademark, manufacturer, or otherwise does not necessarily constitute or imply its endorsement, recommendation, or favoring by the United States Government or any agency thereof. The views and opinions of authors expressed herein do not necessarily state or reflect those of the United States Government or any agency thereof.

DISCLAIMER

Portions of this document may be illegible in electronic image products. Images are produced from the best available original document.

I. INTRODUCTION

Normal products¹ have proven to be a useful tool in the definition of currents and the derivation of their generalized Ward identities in renormalized perturbation theory. In the present work normal product techniques will be applied to a theory of fermions interacting with massive vector mesons, which is of particular interest because of the special restrictions which the principle of gauge invariance places on the definition of observables.

The massive vector meson ("gluon") model describes the interaction of a neutral, mass $m (\neq 0)$ vector field V^μ with a mass $M (\neq 0)$ spinor field Ψ , with formal equations of motion,

$$\begin{aligned} (i\gamma^\mu \partial_\mu - M)\Psi &= eV^\mu \gamma_\mu \Psi \\ \partial^\mu F_{\mu\nu} + m^2 V_\nu &= -e\bar{\Psi} \gamma_\nu \Psi \end{aligned} \quad (1.1)$$

$$F_{\mu\nu} = \partial_\mu V_\nu - \partial_\nu V_\mu \quad \bullet$$

The formulation of this model in Lagrangian field theory has been discussed by various authors.² Our work will be based mainly on the version of Zimmermann,¹ which adopts the BPHZ³ subtraction scheme to avoid divergences.

The notion of gauge invariance has no intrinsic role in the massive vector meson model (this is obvious from the field equations), and becomes relevant only because we insist that the model be expressed in terms of a renormalizable Lagrangian field theory. To see this, we need only look at the Green's function of the meson field equation,

$$\Delta_{F\mu\nu}(x) = \int \frac{d^4 k}{(2\pi)^4} \left(g_{\mu\nu} - \frac{k_\mu k_\nu}{m^2} \right) \frac{(-i)}{k^2 - m^2 + i\epsilon} e^{-ik \cdot x} \quad (1.2)$$

Instead of falling off like k^{-2} as in a scalar theory or in quantum electrodynamics, the Fourier transform of $\Delta_{F\mu\nu}(x)$ is constant for large k , and this leads to a non-renormalizable theory in which the divergence of a Feynman diagram increases with the number of internal meson lines. The method of achieving renormalizability is essentially that of regularization. One introduces an auxiliary vector field with free propagator

$$-i \left(\frac{g_{\mu\nu}}{k^2 - m^2 + i\epsilon} - \frac{k_\mu k_\nu}{m^2} \left(\frac{1}{k^2 - m^2 + i\epsilon} - \frac{1}{k^2 - m_0^2 + i\epsilon} \right) \right), \quad (1.3)$$

where m_0^2 is an arbitrary non-negative number. A renormalizable theory has been achieved, but at a price: the Green's functions now depend on m_0^2 and describe an indefinite-metric Hilbert space with ghost particles ($\partial_\mu A^\mu$ is a free field of mass m_0). As in the Gupta-Bleuler formulation of quantum electrodynamics, one extracts the physical content of the massive vector meson model by means of a gauge principle: the observables of the theory are those quantities which (in a sense to be made more precise in Section II) commute with the free field $\partial_\mu A^\mu$ and which are independent of the ghost-particle mass. Among these will be a physical meson field satisfying the Proca equation (1.1).

An exhaustive study of the gauge-invariant observables in the massive vector meson model is beyond the scope of this article. Rather we shall be interested in developing suitable criteria for checking gauge invariance (Section II) and in the study of a certain important class of observables, namely those which can be expressed in terms of products of fields of low dimension (Section III). For currents bilinear in the fermion field we shall derive Ward identities (Section IV) using the methods of Ref. 1. Of particular

interest will be the Ward identity of the axial-vector current, whose "anomalies"⁴ will be treated systematically in Section IV. In the final section we shall verify using BPHZ methods the result of Adler and Bardeen⁵ that the triangle anomaly has no lowest order radiative corrections.

II. CRITERIA FOR GAUGE INVARIANCE

In this section we shall define precisely what we mean by the gauge invariance of observables in the perturbative vector-meson model. After giving a prescription for calculating the Green's functions of the renormalized fields to arbitrary order in the coupling constant, we shall state two criteria for gauge invariance. These will express in the language of Green's functions the two facets of the gauge principle set forth in the Introduction, namely, commutation with the ghost-particle field and independence of the ghost-particle mass.

A. Specification of the Green's Functions

The effective Lagrangian (Zimmermann's terminology¹) of the vector meson model is

$$\begin{aligned} \mathcal{L}_{\text{EFF}} &= (1+d)\frac{1}{2}\bar{\psi}\gamma^{\mu}\overleftrightarrow{\partial}_{\mu}\psi - (M-c)\bar{\psi}\psi - (1-b)\frac{1}{2}\partial_{\mu}A_{\nu}\partial^{\mu}A^{\nu} \\ &+ (m^2+a)\frac{1}{2}A_{\mu}A^{\mu} + (e+f)\bar{\psi}\gamma^{\mu}\psi A_{\mu} + (1-b-\frac{m^2+a}{m_0^2})\frac{1}{2}(\partial_{\mu}A^{\mu})^2 \\ &= \mathcal{L}_0 + \mathcal{L}_I \end{aligned} \tag{2.1}$$

$$\mathcal{L}_0 = \left[\frac{1}{2}\bar{\psi}\gamma^{\mu}\overleftrightarrow{\partial}_{\mu}\psi - M\bar{\psi}\psi \right] + \left[-\frac{1}{2}\partial_{\mu}A_{\nu}\partial^{\mu}A^{\nu} + \frac{1}{2}m^2A_{\mu}A^{\mu} + (1-\frac{m^2}{m_0^2})\frac{1}{2}(\partial_{\mu}A^{\mu})^2 \right]$$

where the finite renormalization constants a , b , c , d , and f are power series in the coupling constant e whose coefficients (to be fixed eventually by normalization conditions) are functions of the mass parameters of the theory, M , m and

m_0 .

Green's functions (covariant time-ordered functions) may be computed to any order in e by means of the Gell-Mann-Low formula,⁶

$$\begin{aligned} \langle 0 | T \prod_{i=1}^{\ell} A_{\nu_i}(y_i) \prod_{j=1}^m \psi(w_j) \prod_{k=1}^m \bar{\psi}(z_k) | 0 \rangle &= \\ &= \text{Finite part of } \langle 0 | T \prod_{i=1}^{\ell} A_{\nu_i}^{(0)}(y_i) \prod_{j=1}^m \psi^{(0)}(w_j) \prod_{k=1}^m \bar{\psi}^{(0)}(z_k) \\ &\times \exp\{i \int d^4x: \mathcal{L}_I[A_{\nu}^{(0)}, \psi^{(0)}, \bar{\psi}^{(0)}]:\} | 0 \rangle^{(0)} \end{aligned}$$

where $A_{\nu}^{(0)}$ and $\psi^{(0)}$ are the free fields with the propagators specified by the unperturbed Lagrangian \mathcal{L}_0 and the finite part prescription is that of Bogoliubov, Parasiuk, Hepp and Zimmermann (BPHZ).³ Formally the righthand side of (2.2) is the well known sum over Feynman diagrams with the following lines and vertices:

$$\begin{aligned} \text{Fermion line:} & \quad \frac{i}{\not{p}-M} \\ \text{Meson line:} & \quad \frac{-i}{k^2-m^2} (g_{\mu\nu} - \frac{k_{\mu}k_{\nu}}{k^2}) - \frac{i}{k^2-m_0^2} (\frac{m_0^2}{m^2}) \frac{k_{\mu}k_{\nu}}{k^2} \\ \text{Fermion-fermion-meson vertex:} & \quad i(e+f)\gamma_{\mu} \\ \text{Fermion-fermion vertex:} & \quad i(c+d\gamma) \\ \text{Meson-meson vertex:} & \quad i(a+bk^2)g_{\mu\nu} - i(b + \frac{a}{m_0^2})k_{\mu}k_{\nu} \end{aligned}$$

In Zimmermann's version of the BPHZ subtraction scheme, the formal integrand (before integrating over internal loop momenta) I_G corresponding to a Feynman diagram G is replaced by the subtracted integrand

$$R_G = \sum_{U \in \mathcal{S}_G} \prod_{\gamma \in U} (-t_{\gamma}) I_G \quad (2.3)$$

where \mathcal{F}_G is the set of all forests (sets of nonoverlapping one-particle irreducible subdiagrams γ of non-negative degree $\delta(\gamma)$) of G , and t_γ denotes the operation of taking the Taylor series to order $\delta(\gamma)$ in the independent external momenta of γ (about the origin). The degree of a subdiagram γ may be taken in this model as

$$\delta(\gamma) = 4 - \frac{3}{2}F_\gamma - B_\gamma \quad (2.4)$$

where F_γ is the number of external fermion lines and B_γ is the number of external meson lines of γ . The product of Taylor operators in (2.3) is restricted by the requirement that if γ_2 is a subdiagram of γ_1 , then t_{γ_2} stands to the right of t_{γ_1} .

Normal products may be introduced by a slight modification of the Gell-Mann-Low formula.¹ If \mathcal{O}_a , $a = 1, 2, \dots, p$, are formal products of the basic fields and their derivatives with dimensions $d_a \leq \delta_a$, then we define

$$\begin{aligned} \langle 0 | T \prod_{a=1}^p N_{\delta_a} [\mathcal{O}_a](x_a) \prod_{j=1}^m \psi(w_j) \prod_{k=1}^n \bar{\psi}(z_k) | 0 \rangle &= \\ &= \text{Finite part of } \langle 0 | T \prod_{a=1}^p : \mathcal{O}_a^{(0)} : (x_a) \prod_{j=1}^m \psi^{(0)}(w_j) \prod_{k=1}^n \bar{\psi}^{(0)}(z_k) \\ &\times \exp\{i \int d^4x : \mathcal{L}_I[A_\nu^{(0)}, \psi^{(0)}, \bar{\psi}^{(0)}] : \} | 0 \rangle \end{aligned} \quad (2.5)$$

Thus the same Feynman rules given above are applicable, with the additional requirement that each Feynman diagram must contain special vertices V_i , $i = 1, 2, \dots, p$ corresponding to the normal products $N_{\delta_a} [\mathcal{O}_a]$. The renormalized integrands are once again given by the "forest formula" (2.3), but with degree function

$$\delta(\gamma) = 4 - \frac{3}{2}F_\gamma - B_\gamma - \sum_{V_a \in \gamma} (4 - \delta_a) \quad (2.6)$$

The notation of Eq. (2.5) suggests that we are dealing with the covariant time-ordered functions of well defined operator fields. To justify this interpretation one would have to prove the appropriate generalized unitarity relations, a difficult step which has not yet been accomplished. Moreover, as pointed out in Ref. [7], the equations of motion give rise to a certain non-uniqueness of the time-ordered functions. In our opinion neither difficulty poses an insuperable problem, and we feel that we are not being overly optimistic if we assume that (2.5) indeed defines Green's functions of legitimate composite fields, provided (a) the latter contain derivatives and Dirac γ - matrices only in completely traceless combinations and (b) the degree of a normal product $N_a |\mathcal{O}|$ is equal to the dimension of \mathcal{O} . Other composite fields are assumed to be reducible to linear combinations of such normal products in standard form by means of equations of motion and Zimmermann's identities relating normal products of different degree.

B. First Criterion of Gauge Invariance

The basic formula which allows us to state criteria for gauge-invariant fields is the Ward identity

$$\begin{aligned}
 & \langle 0 | T \partial_\mu A^\mu(x) \prod_{i=1}^l A_{\nu_i}(y_i) \prod_{j=1}^m \psi(w_j) \prod_{k=1}^m \bar{\psi}(z_k) | 0 \rangle \\
 & \equiv \partial_\mu^x \langle 0 | T A^\mu(x) \prod_{i=1}^l A_{\nu_i}(y_i) \prod_{j=1}^m \psi(w_j) \prod_{k=1}^m \bar{\psi}(z_k) | 0 \rangle \quad (2.7) \\
 & = - \sum_{i=1}^l \left(\frac{m_0^2}{m^2+a} \right) \partial_{\nu_i} \Delta_F(x-y_i; m_0^2) \langle 0 | T A_{\nu_1}(y_1) \cdots \hat{A}_{\nu_i} \cdots A_{\nu_l}(y_l) \prod_{j=1}^m \psi(w_j) \prod_{k=1}^m \bar{\psi}(z_k) | 0 \rangle \\
 & + i \left(\frac{e+f}{1+d} \right) \left(\frac{m_0^2}{m^2+a} \right) \sum_{j=1}^m \left(\Delta_F(x-w_j; m_0^2) - \Delta_F(x-z_j; m_0^2) \right) \times \\
 & \quad \times \langle 0 | T \prod_{i=1}^l A_{\nu_i}(y_i) \prod_{j=1}^m \psi(w_j) \prod_{k=1}^m \bar{\psi}(z_j) | 0 \rangle
 \end{aligned}$$

where $\Delta_F(\xi; m_0^2)$ is the free, mass m_0 propagator and the caret over the field A_{ν_i} denotes its omission from the time-ordered product. The two contributions to the righthand side of (2.7) arise from the following graphical alternative; either the scalar meson propagator originating at x is connected directly to one of the external meson lines, or it is attached to one of the interaction vertices of the diagram. The first case gives the first term on the righthand side of (2.7), whereas the second gives

$$-i(e+f) \left(\frac{m_0^2}{m^2+a} \right) \int d^4x' \Delta_F(x-x'; m_0^2) \partial'_\mu \langle 0 | T N_3 [\bar{\psi} \gamma^\mu \psi] (x') X | 0 \rangle \quad (2.8)$$

where here and in the following we use the abbreviated notation

$$X \equiv \prod_{i=1}^l A_{\nu_i} (y_i) \prod_{j=1}^m \psi(w_j) \prod \bar{\psi}(z_k)$$

To arrive at (2.7) we must therefore prove the following vector-current Ward identity.

$$(1+d) \partial_x^\mu \langle 0 | T N_3 [\bar{\psi} \gamma_\mu \psi] (x) X | 0 \rangle = \sum_{j=1}^m [\delta(x-z_j) - \delta(x-w_j)] \langle 0 | T X | 0 \rangle \quad (2.9)$$

It is an easy consequence of the properties of Zimmermann's normal products¹ that

$$\begin{aligned} \partial_x^\mu \langle 0 | T N_3 [\bar{\psi} \gamma_\mu \psi] (x) X | 0 \rangle &= \langle 0 | T N_4 [\partial^\mu (\bar{\psi} \gamma_\mu \psi)] (x) X | 0 \rangle \\ &= -i \langle 0 | T N_4 [\bar{\psi} (i\vec{\beta} - M) \psi] (x) X | 0 \rangle \\ &+ i \langle 0 | T N_4 [\bar{\psi} (-i\vec{\beta} - M) \psi] (x) X | 0 \rangle \end{aligned} \quad (2.10)$$

The verification of (2.9) thus reduces to establishing the equation of motion for ψ within the normal product,

$$\begin{aligned} \langle 0 | T N_4 [\bar{\psi}(i\cancel{\partial} - m)\psi](x) X | 0 \rangle &= \langle 0 | T N_4 [\bar{\psi}(-id\cancel{\partial} - c - (e+f)\cancel{\mathcal{K}})\psi](x) X | 0 \rangle \\ &- i \sum_{j=1}^m \delta(x-w_j) \langle 0 | T X | 0 \rangle \end{aligned} \quad (2.11)$$

Eq.(2.11) follows from the graphical argument, strictly analogous to the scalar case treated in Ref. [7], depicted in Fig. 1.

From (2.7) we may verify (using the reduction formula) that the Klein-Gordon equation

$$(\partial^2 + m_0^2) \partial_\mu A^\mu = 0 \quad (2.12)$$

holds as an operator relation. Moreover, we see that ghost mesons interact with fermions in a very restricted way: we need include only those Feynman diagrams in which the scalar meson line passes through without interacting or in which it interacts with an entering or existing fermion line.

The above considerations indicate that "probing with a ghost particle", i.e. attaching an external scalar meson line to a Feynman diagram, may be a good way to rest for gauge invariance. In particular, we shall say that fields $\phi^{(\alpha)}(x)$ satisfy the first criterion of gauge invariance if they have covariant Green's functions (to be denoted \hat{T} - functions) with the property

$$\begin{aligned} \langle 0 | \hat{T} \partial_\mu A^\mu(x) \prod_{s=1}^N \phi^{(\alpha_s)}(x_s) X | 0 \rangle \\ = -i \sum_{i=1}^l \left(\frac{m_0^2}{m^2+a} \right) \partial_{\nu_i} \Delta_F(x-y_i; m_0^2) \langle 0 | \hat{T} \prod_{s=1}^N \phi^{(\alpha_s)}(x_s) X \uparrow | 0 \rangle \\ + i \left(\frac{e+f}{1+d} \right) \left(\frac{m_0^2}{m^2+a} \right) \sum_{j=1}^m \left(\Delta_F(x-w_j; m_0^2) - \Delta_F(x-z_j; m_0^2) \right) \langle 0 | \hat{T} \prod_{s=1}^N \phi^{(\alpha_s)}(x_s) X | 0 \rangle \end{aligned} \quad (2.13)$$

for all $\{\alpha_s\}$ and for arbitrary products of the basic fields,

$$X = \prod_{i=1}^l A_{\nu_i}(y_i) \prod_{j=1}^m \psi(w_j) \prod_{k=1}^m \bar{\psi}(z_k).$$

Here X_{Λ} denotes X with the field A_{ν_i} (y_i) missing.

Criterion (2.13) is the first part of the gauge principle enunciated in the Introduction. It is the Green's function analogue of

$$[\partial_{\mu} A^{\mu}(x), \prod_{s=1}^N \phi^{(s)}(x_s)] = 0 \quad (2.14)$$

The main point is that if a physical Hilbert space \mathcal{H} is constructed by acting on the vacuum with fields satisfying either (2.13) or (2.14), then $\partial_{\mu} A^{\mu}$ is identically zero in \mathcal{H} . This follows from the positive-negative frequency decomposition of $\partial_{\mu} A^{\mu}$ in (2.14), and, assuming asymptotic completeness in \mathcal{H} , from the reduction formula applied to (2.13).

It is easily verified that the first criterion is satisfied, with $\hat{T}=T$, not only by the "electromagnetic" field $F_{\mu\nu} = \partial_{\mu} A_{\nu} - \partial_{\nu} A_{\mu}$ (this follows immediately from (2.7)), but also by the "physical" meson field

$$V_{\mu} = A_{\mu} + \frac{1}{m_0^2} \partial_{\mu} \partial^{\nu} A_{\nu}, \quad (2.15)$$

provided the second derivatives are taken outside the time-ordering symbol without picking up contact terms (we adopt this convention for V_{μ}) and by all formally gauge invariant normal products. By formal gauge invariance of a product of basic fields we mean that ψ and $\bar{\psi}$ fields are present in equal numbers, and the A_{μ} field and derivatives of the fermion fields enter only in the combinations $F_{\mu\nu}$, $(\partial_{\mu} - ieA_{\mu})\psi$ and $\bar{\psi}(\overleftarrow{\partial}_{\mu} + ieA_{\mu})$. The graphical argument leading to (2.7) is altered only by inclusion of diagrams in which the ghost-particle propagator is attached to one of the lines emanating from the normal product vertex. That these cancel for all formally gauge invariant normal products is left as an exercise for the reader.

C. Second Criterion for Gauge Invariance

Suppose $\phi^{(\alpha)}$ are formally gauge invariant composite fields whose \hat{T} -functions satisfy (2.13). We shall say that the $\phi^{(\alpha)}$ fulfill the second criterion if the following identity holds:

$$\begin{aligned} \frac{\partial}{\partial m_0^2} \langle 0 | \hat{T} \prod_{s=1}^N \phi^{(\alpha_s)}(x_s) X | 0 \rangle & \quad (2.16) \\ = \frac{i}{2} \left(\frac{m^2+a}{m_0^4} \right) \int d^4x \langle 0 | \hat{T} : (\partial_\mu A^\mu)^2 : (x) \prod_{s=1}^N \phi^{(\alpha_s)}(x_s) X | 0 \rangle \end{aligned}$$

for all choices of $\{\alpha_s\}$ and X . (Note that in the BPHZ subtraction scheme, the Wick product in the righthand member of (2.16) is really a normal product of degree zero. That the righthand side is well defined with so few subtractions is a simple consequence of (2.13).)

The second criterion, which includes the requirement that all Green's functions containing only gauge invariant fields are independent of the ghost-particle mass, is not a trivial matter to establish. As we shall see in Section III, Zimmermann's normal products normalized at the origin do not automatically satisfy it, and much of the remainder of this article will be devoted to defining normal product fields and their time ordered functions in such a way that the second criterion is satisfied. In this section we shall content ourselves with a special case of (2.16), namely,

$$\frac{\partial}{\partial m_0^2} \langle 0 | T X | 0 \rangle = \frac{i}{2} \left(\frac{m^2+a}{m_0^4} \right) \int d^4x \langle 0 | T : (\partial_\mu A^\mu)^2 : (x) X | 0 \rangle \quad (2.17)$$

which, with (2.7), implies the gauge invariance of the S-matrix and which will place certain restrictions on the renormalization constants a, b, c, d and f (see (2.1)) which we have thus far left undetermined.

Equation (2.17) is most easily proved using the method of differential vertex operations (integrated normal products).⁸

Define
$$\Delta_j = \frac{i}{n_j!} \int N_4[\mathcal{O}_j] d^4x \quad j=1,2,\dots,6$$

$$\begin{aligned} \mathcal{O}_1 &= A_\mu A^\mu & \mathcal{O}_4 &= \frac{i}{2} \bar{\psi} \gamma^\mu \overleftrightarrow{\partial}_\mu \psi \\ \mathcal{O}_2 &= \partial_\mu A^\nu \partial^\mu A_\nu & \mathcal{O}_5 &= \bar{\psi} \gamma^\mu \psi A_\mu \\ \mathcal{O}_3 &= \bar{\psi} \psi & \mathcal{O}_6 &= (\partial_\mu A^\mu)^2 \end{aligned}$$

In terms of the Δ_j , the effective action integral takes the form

$$\begin{aligned} iA_{\text{EFF}} &= \int d^4x N_4[\mathcal{L}_{\text{EFF}}] = (m^2+a)\Delta_1 + (b-1)\Delta_2 + (c-M)\Delta_3 \\ &+ (d+1)\Delta_4 + (e+f)\Delta_5 + (1-b - \frac{m^2+a}{m_0^2}) \Delta_6 \end{aligned} \quad (2.19)$$

Now we apply the following result of Ref. [8]: If $iA_{\text{EFF}} = \sum_k c_k \Delta_k$ with the coefficients c_k functions of parameters a_i , then for any Green's function (or vertex function) G ,

$$\frac{\partial G}{\partial a_i} = \sum_k \frac{\partial c_k}{\partial a_i} \Delta_k G. \quad (2.20)$$

In our case

$$\begin{aligned} \frac{\partial G}{\partial m_0^2} &= \left(\frac{\partial a}{\partial m_0^2} \Delta_1 + \frac{\partial b}{\partial m_0^2} \Delta_2 + \frac{\partial c}{\partial m_0^2} \Delta_3 + \frac{\partial d}{\partial m_0^2} \Delta_4 + \frac{\partial f}{\partial m_0^2} \Delta_5 \right. \\ &\quad \left. - \frac{\partial}{\partial m_0^2} \left(b + \frac{m^2+a}{m_0^2} \right) \Delta_6 \right) G \end{aligned} \quad (2.21)$$

On the other hand, from Zimmermann's work we know that the integrated Wick product may also be written as a linear combination of the integrated normal products of

degree four. The coefficients may be determined using the normalization conditions for the latter. Thus we have (as a relation among differential vertex operations)

$$\frac{i}{2} \int d^4x :(\partial_\mu A^\mu)^2:(x) = \sum_{i=1}^5 r_i \Delta_i + \Delta_6 \quad (2.22)$$

with

$$r_1 = \frac{1}{8} \int d^4x \langle 0 | T :(\partial_\mu A^\mu)^2:(x) \tilde{A}_\mu(0) \tilde{A}^\mu(0) | 0 \rangle^{\text{PROP}'}$$

$$r_2 = \frac{1}{8} \int d^4x \left[\frac{\partial}{\partial k^2} \langle 0 | T :(\partial_\mu A^\mu)^2:(x) \tilde{A}_\mu(k) \tilde{A}^\mu(-k) | 0 \rangle^{\text{PROP}'} \right]_{k=0}$$

$$r_3 = \frac{1}{8} \text{Tr} \int d^4x \langle 0 | T :(\partial_\mu A^\mu)^2:(x) \tilde{\psi}(0) \tilde{\psi}(0) | 0 \rangle^{\text{PROP}}$$

$$r_4 = \frac{1}{32} \text{Tr} \gamma^\mu \int d^4x \left[\frac{\partial}{\partial p^\mu} \langle 0 | T :(\partial_\mu A^\mu)^2:(x) \tilde{\psi}(p) \tilde{\psi}(-p) | 0 \rangle^{\text{PROP}} \right]_{p=0}$$

$$r_5 = \frac{1}{32} \text{Tr} \gamma^\mu \int d^4x \langle 0 | T :(\partial_\mu A^\mu)^2:(x) \tilde{\psi}(0) \tilde{\psi}_\mu(0) \tilde{A}_\mu(0) | 0 \rangle^{\text{PROP}}$$

where the tildes denote Fourier transformation of the T-function:

$$\langle 0 | T \tilde{A}_\mu(k) X | 0 \rangle \equiv \int d^4x e^{ikx} \langle 0 | T A_\mu(x) X | 0 \rangle,$$

the superscript PROP indicates that only one-particle irreducible diagrams are included, and PROP' is the same as PROP except that trivial diagrams with a single vertex are excluded. From (2.7), it is clear that r_1 and r_2 both vanish, since the proper parts are necessarily transverse in their external meson momenta. Moreover, it is a consequence of the Ward identity (2.9) that $r_5 = (e+f) r_4$.

Comparing (2.21) and (2.22), we see that (2.17) may be enforced by setting

$$\begin{aligned}
 a &= a_0 \\
 b &= b_0 \\
 c &= c_0 + \int_0^{m_0^2} dm_0'^2 \left(\frac{m^2+a}{m_0'^4} \right) r_3(m, M, m_0', e) \\
 d &= d_0 + \int_0^{m_0^2} dm_0'^2 \left(\frac{m^2+a}{m_0'^4} \right) r_4(m, M, m_0', e) \\
 f &= f_0 + \int_0^{m_0^2} dm_0'^2 \left(\frac{m^2+a}{m_0'^4} \right) r_5(m, M, m_0', e)
 \end{aligned}$$

where a_0 , b_0 , c_0 , d_0 , and f_0 are independent of the ghost mass. It should be observed that the integrals in (2.23) vanish in the limit of the Landau gauge, $m_0=0$, the integrands being at worst logarithmically divergent.

The constants a_0 and b_0 are to be determined by the normalization conditions fixing the position and residue of the meson propagator pole:

$$\Pi(m^2) = 0 = \left. \frac{\partial \Pi(p)}{\partial p^2} \right|_{p^2=m^2}$$

where

$$\Delta'_{F\mu\nu}(k) = -i \left(g_{\mu\nu} - \frac{k_\mu k_\nu}{k^2} \right) \left(\frac{1}{k^2 - m^2 - \Pi(k^2)} \right) - i \frac{k_\mu k_\nu}{k^2} \left(\frac{m_0^2}{m^2+a} \right) \left(\frac{1}{k^2 - m_0^2} \right)$$

(2.24)

and

$$\langle 0 | T A_\mu(x) A_\nu(y) | 0 \rangle = \int \frac{d^4 k}{(2\pi)^4} e^{-ik(x-y)} \Delta'_{F\mu\nu}(k)$$

In addition, the combination $c_0 + M d_0$ is fixed by the interpretation of M as the physical fermion mass:

$$\Sigma(p) \Big|_{\not{p}=M} = 0$$

where

$$\not{S}_F^{-1}(p) = \frac{i}{\not{p} - M - \Sigma(p)} \quad (2.25)$$

and

$$\langle 0 | T \psi(x) \bar{\psi}(y) | 0 \rangle = \int \frac{d^4 p}{(2\pi)^4} e^{-ip(x-y)} \not{S}_F^{-1}(p)$$

Finally, d_0 and f_0 are conventionally either set equal to zero (intermediate normalization in the Landau gauge) or may be determined by the mass shell normalization conditions,

$$[\gamma^\mu \frac{\partial \Sigma}{\partial \not{p}^\mu}]_{\not{p}=M} = 0$$

$$\frac{1}{4} [\gamma^\mu \Gamma_\mu(p, 0)]_{\not{p}=M} = ie \quad (2.26)$$

$$\langle 0 | T \psi(x) \bar{\psi}(y) A_\mu(z) | 0 \rangle \stackrel{\text{prop}}{=} \int \frac{d^4 p}{(2\pi)^4} \frac{d^4 q}{(2\pi)^4} \frac{d^4 k}{(2\pi)^4} e^{-i(px+qy+kz)} \\ \times (2\pi)^4 \delta(p+q+k) \Gamma_\mu(p, k)$$

It is not difficult to verify that the normalization conditions (2.24-26) actually determine a_0 , b_0 , c_0 , d_0 and f_0 which are independent of m_0 . It should be noted that the explicit calculation of c_0 , d_0 and f_0 is not necessary with mass shell normalization, since c , d and f may be determined directly from equations (2.25) and (2.26). This advantage is offset, however, if one wishes to take the electrodynamic limit, $m \rightarrow 0$, without encountering infrared divergences.

III. GAUGE INVARIANT NORMAL PRODUCTS

We now turn to the problem of defining covariant time-ordered functions (\hat{T} -functions) and formally gauge invariant normal products with the property that both criteria of the preceding section are satisfied.

Before considering the most general Green's function involving composite fields, it is instructive to consider the simple case of a single field of the form $N_3[\bar{\psi}_i \psi_j]$, proceeding in a manner parallel to that used to derive (2.17). The only additional complication comes from the fact that the normal product vertex introduces a new class of m_0 -dependent BPHZ subtractions, which must be compensated in some way to insure the validity of (2.16). Eqs. (2.21) and (2.22) now take the form

$$\frac{\partial G_{ij}}{\partial m_0^2} = \left(\frac{\partial c}{\partial m_0^2} \Delta_3 + \frac{\partial d}{\partial m_0^2} \Delta_4 + \frac{\partial f}{\partial m_0^2} \Delta_5 + \frac{m_0^2 + a}{m_0^4} \Delta_6 \right) G_{ij} \quad (3.1)$$

$$G_{ij} = \langle 0 | T N_3[\bar{\psi}_i \psi_j](x) X | 0 \rangle$$

and

$$\frac{i}{2} \int d^4 y \langle 0 | T :(\partial_\mu A^\mu)^2 : (y) N_3[\bar{\psi}_i \psi_j](x) X | 0 \rangle \quad (3.2)$$

$$= \Delta_6 G_{ij} + \sum_{k=3}^5 r_k \Delta_k G_i - u_{ijmn} G_{mn}$$

where the r_k are the same as in (2.22) and

$$u_{ijkl} = \frac{-i}{2} \int d^4 y \langle 0 | T :(\partial_\mu A^\mu)^2 : (y) N_3[\bar{\psi}_i \psi_j](0) \tilde{\psi}_k(0) \tilde{\psi}_l(0) | 0 \rangle^{\text{prop.}}$$

With the choice of renormalization constants (2.23), Eqs. (3.1) and (3.2) may be combined to give

$$\delta' G_{ij} = u_{ijkl} G_{kl} \quad (3.3)$$

where

$$\delta = \frac{m_0^4}{m^2 + a} \frac{\partial}{\partial m_0^2} - \frac{1}{2} \int d^4 y :(\partial_\mu A^\mu)^2:(y)$$

The nonvanishing righthand side of (3.3) has its origin in the fact that

$$\Delta_6 \equiv \frac{1}{2} \int d^4 x N_4 [(\partial_\mu A^\mu)^2](x) \quad \text{and} \quad \frac{1}{2} \int d^4 x :(\partial_\mu A^\mu)^2:(x)$$

require different numbers of subtractions for proper subgraphs of the type pictured in Fig. 2. The N_4 normal product prescribes subtraction of the zeroth order Taylor term, whereas the Wick product requires no subtraction. Moreover this is the only type of proper subgraph containing $N_3[\bar{\psi}_i \psi_j]$ where there will be a distinction between the two subtraction schemes. Thus, from Ref. 1 we know there will be a term proportional to G_{mn} on the righthand sides of (3.2) and (3.3). The coefficient u_{ijmn} is most easily evaluated using the normalization condition

$$\langle 0 | T N_3[\bar{\psi}_i \psi_j](0) \hat{\psi}_k(0) \bar{\psi}_l(0) | 0 \rangle^{\text{PROP}} = \delta_{ik} \delta_{jl} \quad (3.4)$$

We now wish to define gauge invariant normal products of degree three by taking linear combinations of the various $N_3[\bar{\psi}_i \psi_j]$. Let us write

$$\langle 0 | \hat{T} N_3[\bar{\psi}_i \psi_j] X | 0 \rangle \equiv \langle 0 | T \hat{N}_3[\bar{\psi}_i \psi_j] X | 0 \rangle \quad (3.5)$$

where

$$\hat{N}_3[\bar{\psi}_i \psi_j] = a_{ijkl} N_3[\bar{\psi}_k \psi_l]$$

and the coefficients are to be determined by the second criterion,

$$\delta \langle 0 | \hat{T} \mathcal{N}_3[\bar{\psi}_i \psi_j] X | 0 \rangle = 0 \quad (3.6)$$

and appropriate normalization conditions. Convenient choices for the latter are

(i) intermediate normalization in the Landau gauge,

$$\langle 0 | \hat{T} \mathcal{N}_3[\bar{\psi}_i \psi_j](0) \tilde{\psi}_k(0) \tilde{\psi}_l(0) | 0 \rangle^{\text{prop}} \Big|_{m_0=0} = \delta_{ik} \delta_{jl} \quad (3.7)$$

and (ii) mass-shell normalization,

$$\langle 0 | \hat{T} \mathcal{N}_3[\bar{\psi}_i \psi_j](0) \tilde{\psi}_k(p) \tilde{\psi}_l(-p) | 0 \rangle^{\text{prop}} \Big|_{p^2=m^2} = \delta_{ik} \delta_{jl} \quad (3.8)$$

Requirement (3.6) implies

$$\begin{aligned} 0 &= a_{ijkl} \delta G_{kl} + \frac{m_0^4}{m^2+a} \frac{\partial a_{ijkl}}{\partial m_0^2} G_{kl} \\ &= \left(a_{ijkl} u_{klmn} + \frac{m_0^4}{m^2+a} \frac{\partial a_{ijmn}}{\partial m_0^2} \right) G_{mn} \end{aligned} \quad (3.9)$$

so that

$$a_{ijkl} = - \int_0^{m_0^2} \frac{m^2+a}{m_0'^4} a_{ijmn} u_{mnkl} dm_0'^2 + a_{ijkl}^0 \quad (3.10)$$

where a_{ijkl}^0 is independent of m_0 . Eq. (3.10) is an integral equation which can be solved recursively to any order in perturbation theory. In the case of intermediate normalization we choose $a_{ijkl}^0 = 0$, whereas for mass-shell normalization we choose a_{ijkl}^0 such that (3.8) is satisfied. That this is possible is a consequence of the m_0 -independence of (3.8),

$$\begin{aligned} & \frac{m_0^4}{m^2+a} \frac{\partial}{\partial m_0^2} \langle 0 | \hat{T} \gamma_3 [\bar{\psi}_i \psi_j](0) \hat{\psi}_k(p) \tilde{\psi}_\ell(-p) | 0 \rangle^{\text{prop}} \Big|_{\not{p}=m} \quad (3.11) \\ & = \frac{i}{2} \int d^4 y \langle 0 | T : (\partial_\mu A^\mu)^2 : (y) \hat{N}_3 [\bar{\psi}_i \psi_j](0) \hat{\psi}_k(p) \tilde{\psi}_\ell(-p) | 0 \rangle^{\text{prop}} \Big|_{\not{p}=m} = 0. \end{aligned}$$

Note that mass-shell normalization has the advantage that the coefficients a_{ijkl} may be determined directly from (3.8), without resorting to (3.10).

The above formulas become particularly simple when $N_3[\bar{\psi}_i \psi_j]$ is contracted with one of the matrices $\Gamma = 1, \gamma^5, \gamma^\mu, \gamma^\mu \gamma^5$. Then considerations of Lorentz invariance and parity imply

$$\Gamma_{ij} u_{ijkl} = u \Gamma_{kl} \quad (3.12)$$

$$\Gamma_{ij} a_{ijkl} = \alpha \Gamma_{kl}$$

with

$$\alpha = - \int_0^{m_0^2} \frac{m_0^2+a}{m_0'^4} \alpha u dm_0'^2 + \alpha^0$$

$$\frac{\partial \alpha^0}{\partial m_0^2} = 0$$

so that the second criterion of gauge invariance is fulfilled by simply multiplying by the m_0 - dependent factor α :

$$\langle 0 | \hat{T} \mathcal{N}_3[\bar{\psi}\Gamma\psi](x) X | 0 \rangle \equiv \alpha \langle 0 | T N_3[\bar{\psi}\Gamma\psi](x) X | 0 \rangle \quad (3.13)$$

Formally gauge invariant normal products of degree four may be treated similarly. By the same reasoning which led to (3.3), we have

$$\begin{aligned} \delta \langle 0 | T N_4[\mathcal{O}](x) X | 0 \rangle \\ = u_{ij}[\mathcal{O}] \langle 0 | T N_4[\bar{\psi}_i\psi_j](x) X | 0 \rangle \\ + v_{ij}^\mu[\mathcal{O}] \partial_\mu \langle 0 | T N_3[\bar{\psi}_i\psi_j](x) X | 0 \rangle + w_{ij}^\mu[\mathcal{O}] \langle 0 | T N_4[\bar{\psi}_i \overset{\delta}{\leftarrow} \left(\frac{\mu}{2} 1eA_\mu \right) \psi_j](x) X | 0 \rangle \end{aligned} \quad (3.14)$$

where

$$u_{ij}[\mathcal{O}] = -\frac{1}{2} \int d^4y \langle 0 | T :(\partial_\mu A^\mu)^2: (y) N_4[\mathcal{O}](0) \tilde{\psi}_i(0) \tilde{\psi}_j(0) | 0 \rangle^{\text{prop}}$$

$$v_{ij}^\mu[\mathcal{O}] = -\frac{1}{2} \frac{\partial}{\partial p_\mu} \int d^4y \langle 0 | T :(\partial_\mu A^\mu)^2: (y) N_4[\mathcal{O}](0) \tilde{\psi}_i\left(\frac{p}{2}\right) \tilde{\psi}_j\left(\frac{p}{2}\right) | 0 \rangle^{\text{prop}} \Big|_{p=0}$$

$$w_{ij}^\mu[\mathcal{O}] = \frac{1}{2e} \int d^4y \langle 0 | T :(\partial_\mu A^\mu)^2: (y) N_4[\mathcal{O}](0) \tilde{\psi}_i(0) \tilde{\psi}_j(0) \tilde{A}^\mu(0) | 0 \rangle^{\text{prop}}$$

The BPHZ subtractions giving rise to the various terms on the righthand side of (3.14) are displayed in Fig. 3.

Defining

$$\langle 0 | \hat{T} \mathcal{N}_4[\mathcal{O}](x) X | 0 \rangle \equiv \langle 0 | T \hat{N}_4[\mathcal{O}](x) X | 0 \rangle \quad (3.15)$$

where

$$\hat{N}_4[\mathcal{O}] = N_4[\mathcal{O}] + a_{ij} N_4[\bar{\psi}_i \psi_j] + b_{ij}^\mu a_\mu N_3[\bar{\psi}_i \psi_j] + c_{ij}^\mu N_4[\bar{\psi}_i (\overset{\leftrightarrow}{\frac{\partial}{\partial x^\mu}} - ieA_\mu) \psi_j]$$

we obtain

$$\begin{aligned} & \delta \langle 0 | \hat{T} \mathcal{N}_4[\mathcal{O}](x) X | 0 \rangle \\ &= \langle 0 | T N_4[\bar{\psi}_i \psi_j](x) X | 0 \rangle \left(\frac{m_0^4}{m^2+a} \frac{\partial a_{ij}}{\partial m_0^2} + u_{ij}[\mathcal{O}] + a_{kl} u_{kl}[\bar{\psi}_i \psi_j] \right. \\ & \quad \left. + c_{kl}^\mu u_{kl}[\bar{\psi}_i (\overset{\leftrightarrow}{\frac{\partial}{\partial x^\mu}} - ieA_\mu) \psi_j] \right) \\ & \quad + \partial_\mu \langle 0 | T N_3[\bar{\psi}_i \psi_j](x) X | 0 \rangle \left(\frac{m_0^4}{m^2+a} \frac{\partial b_{ij}^\mu}{\partial m_0^2} + v_{ij}^\mu[\mathcal{O}] + a_{kl} v_{kl}[\bar{\psi}_i \psi_j] \right) \quad (3.16) \\ & \quad \left. + b_{kl}^\mu u_{kl} + c_{kl}^\nu v_{kl}[\bar{\psi}_i (\overset{\leftrightarrow}{\frac{\partial}{\partial x^\nu}} - ieA_\nu) \psi_j] \right) \\ & \quad + \langle 0 | T N_4[\bar{\psi}_i (\overset{\leftrightarrow}{\frac{\partial}{\partial x^\mu}} - ieA_\mu) \psi_j](x) X | 0 \rangle \left(\frac{m_0^4}{m^2+a} \frac{\partial c_{ij}^\mu}{\partial m_0^2} + w_{ij}^\mu[\mathcal{O}] + a_{kl} w_{kl}^\mu[\bar{\psi}_i \psi_j] \right. \\ & \quad \left. + c_{kl}^\nu w_{kl}^\mu[\bar{\psi}_i (\overset{\leftrightarrow}{\frac{\partial}{\partial x^\nu}} - ieA_\nu) \psi_j] \right). \end{aligned}$$

Setting the righthand side of (3.16) equal to zero, as required by the second criterion of gauge invariance, and integrating with respect to m_0^2 , we are left with a set of integral equations which may be solved iteratively in perturbation theory. Once again the constants of integration must be fixed by appropriate

normalization conditions.

As a simple example which will be needed later, consider

$$\mathcal{O} = F_{\mu\nu} F^{\mu\nu} \equiv F_{\mu\nu} F_{\kappa\lambda} \epsilon^{\mu\nu\kappa\lambda} \quad (3.17)$$

In this case

$$\begin{aligned} u_{ij}[\mathcal{O}] &= 0 = w_{ij}^{\mu}[\mathcal{O}] \\ v_{ij}^{\mu}[\mathcal{O}] &= v(\gamma^{\mu}\gamma^5)_{ij} \end{aligned} \quad (3.18)$$

A convenient set of solutions of (3.16) set equal to zero is provided by

$$\begin{aligned} a_{ij} &= c_{ij}^{\mu} = 0 \\ b_{ij}^{\mu} &= \beta(\gamma^{\mu}\gamma^5)_{ij} \end{aligned} \quad (3.19)$$

$$\beta = - \int_0^{m_0^2} \frac{m_0^2 + a}{m_0^4} (v + \beta u) dm_0'^2 + \beta^0$$

where β^0 is independent of m_0 but otherwise arbitrary, and u is defined in (3.12) with $\Gamma = \gamma^{\mu}\gamma^5$.

In order to generalize the preceding discussion to time-ordered functions of more than one gauge-invariant composite field, we consider the case of two normal products of degree three and two of degree four. This example incorporates all of the important features of the general situation. As before, the second criterion of gauge invariance fails for

$$\langle 0 | T N_3[A] N_3[B] N_4[C] N_4[D] X | 0 \rangle \quad (3.20)$$

thanks to the different number of subtractions required by $:(\partial_{\mu} A^{\mu})^2:$ and $N_4[(\partial_{\mu} A^{\mu})^2]$. The discrepancy may be partially compensated by replacing the

N's by \hat{N} 's in (3.20). There will remain, however, nonvanishing contributions from various subgraphs (depicted in Fig. 4) containing more than one normal product vertex in addition to the $(\partial_\mu A^\mu)^2$ vertex. Thus, with the simplified notation,

$$\begin{aligned}\hat{A} &\equiv \hat{N}_3[A](x_A) & \hat{C} &\equiv \hat{N}_4[C](x_C) \\ \hat{B} &\equiv \hat{N}_3[B](x_B) & \hat{D} &\equiv \hat{N}_4[D](x_D)\end{aligned}$$

$$\delta(AC) \equiv \delta(x_A - x_{AC})\delta(x_C - x_{AC})$$

$$\delta(ACD) = \delta(x_A - x_{ACD})\delta(x_C - x_{ACD})\delta(x_D - x_{ACD})$$

we have

$$\begin{aligned}&\delta\langle 0 | T \hat{A} \hat{B} \hat{C} \hat{D} X | 0 \rangle \\ &= \left\{ u_{ij}^{AC} \int d^4 x_{AC} \delta(AC) \langle 0 | T N_3[\bar{\psi}_i \psi_j](x_{AC}) \hat{B} \hat{D} X | 0 \rangle \right. \\ &\quad \left. + (A \leftrightarrow B) + (C \leftrightarrow D) + (A \leftrightarrow B, C \leftrightarrow D) \right\} \\ &\quad + \left\{ u_{ij}^{ACD} \int d^4 x_{ACD} \delta(ACD) \langle 0 | T N_3[\bar{\psi}_i \psi_j](x_{ACD}) \hat{B} X | 0 \rangle + (A \leftrightarrow B) \right\} \quad (3.21) \\ &\quad + u_{ij}^{CD} \int d^4 x_{CD} \delta(CD) \langle 0 | T N_4[\bar{\psi}_i \psi_j](x_{CD}) \hat{A} \hat{B} X | 0 \rangle \\ &\quad + \int d^4 x_{CD} \left(u_{ij\mu}^{CD,C} \frac{\partial}{\partial x_{C\mu}} + u_{ij\mu}^{CD,D} \frac{\partial}{\partial x_{D\mu}} \right) \delta(CD) \langle 0 | T N_3[\bar{\psi}_i \psi_j](x_{CD}) \hat{A} \hat{B} X | 0 \rangle \\ &\quad + u_{ij\mu}^{CD} \int d^4 x_{CD} \delta(CD) \langle 0 | T N_4[\bar{\psi}_i (\frac{1}{2} \overleftrightarrow{\partial}^\mu - ieA^\mu) \psi_j](x_{CD}) \hat{A} \hat{B} X | 0 \rangle\end{aligned}$$

where

$$\begin{aligned}
 u_{ij}^{AC} &= -\frac{1}{2} \int d^4 y \langle 0 | T : (\partial_\rho A^\rho)^2 : (y) \hat{A}(0) \hat{C}(0) \hat{\psi}_i(0) \hat{\psi}_j(0) | 0 \rangle^{\text{PROP}} \\
 u_{ij}^{ACD} &= -\frac{1}{2} \int d^4 y \langle 0 | T : (\partial_\rho A^\rho)^2 : (y) \hat{A}(0) \hat{C}(0) \hat{D}(0) \hat{\psi}_i(0) \hat{\psi}_j(0) | 0 \rangle^{\text{PROP}} \quad (3.22) \\
 u_{ij\mu}^{CD,C} &= -\frac{1}{2} \frac{\partial}{\partial p^\mu} \int d^4 y \langle 0 | T : (\partial_\rho A^\rho)^2 : (y) \hat{C}(p) \hat{D}(0) \hat{\psi}_i(-\frac{p}{2}) \hat{\psi}_j(-\frac{p}{2}) | 0 \rangle^{\text{PROP}} \Big|_{p=0} \\
 u_{ij\mu}^{CD} &= \frac{1}{2e} \int d^4 y \langle 0 | T : (\partial_\rho A^\rho)^2 : (y) \hat{C}(0) \hat{D}(0) \hat{\psi}_i(0) \hat{\chi}_\mu(0) \hat{\psi}_j(0) | 0 \rangle^{\text{PROP}}
 \end{aligned}$$

Examination of (3.) suggests the following definition:

$$\begin{aligned}
 &\langle 0 | \hat{T} \mathcal{N}_3[A](x_A) \mathcal{N}_3[B](x_B) \mathcal{N}_4[C](x_C) \mathcal{N}_4[D](x_D) X | 0 \rangle \\
 &\equiv \langle 0 | T \hat{A} \hat{B} \hat{C} \hat{D} X | 0 \rangle \\
 &+ \left\{ a_{ij}^{AC} \int d^4 x_{AC} \delta(AC) \langle 0 | T \mathcal{N}_3[\bar{\psi}_i \psi_j](x_{AC}) \hat{B} \hat{D} X | 0 \rangle \right. \\
 &+ (A \leftrightarrow B) + (C \leftrightarrow D) + (A \leftrightarrow B, C \leftrightarrow D) \left. \right\} \\
 &+ \left\{ a_{ij}^{ACD} \int d^4 x_{ACD} \delta(ACD) \langle 0 | T \mathcal{N}_3[\bar{\psi}_i \psi_j](x_{ACD}) \hat{B} X | 0 \rangle + (A \leftrightarrow B) \right\} \quad (3.23) \\
 &+ a_{ij}^{CD} \int d^4 x_{CD} \delta(CD) \langle 0 | T \mathcal{N}_4[\bar{\psi}_i \psi_j](x_{CD}) \hat{A} \hat{B} X | 0 \rangle \\
 &+ \int d^4 x_{CD} \left(a_{ij\mu}^{CD,C} \frac{\partial}{\partial x_{C\mu}} + a_{ij\mu}^{CD,D} \frac{\partial}{\partial x_{D\mu}} \right) \delta(CD) \langle 0 | T \mathcal{N}_3[\bar{\psi}_i \psi_j](x_{CD}) \hat{A} \hat{B} X | 0 \rangle \\
 &+ a_{ij\mu}^{CD} \int d^4 x_{CD} \delta(CD) \langle 0 | T \mathcal{N}_4[\bar{\psi}_i (\frac{1}{2} \overleftrightarrow{\partial}^\mu - ieA^\mu) \psi_j](x_{CD}) \hat{A} \hat{B} X | 0 \rangle \\
 &+ \left\{ a_{ij}^{AC} a_{kl}^{BD} \int d^4 x_{AC} \int d^4 x_{BD} \delta(AC) \delta(BD) \langle 0 | T \mathcal{N}_3[\bar{\psi}_i \psi_j](x_{AC}) \mathcal{N}_3[\bar{\psi}_k \psi_l](x_{BD}) X | 0 \rangle \right. \\
 &+ (A \leftrightarrow B) \left. \right\}
 \end{aligned}$$

where the a_{ij}^{AC} , a_{ij}^{ACD} , etc. are to be determined by the second criterion of gauge invariance and appropriate normalization conditions. The freedom to choose these coefficients arbitrarily is just the freedom to

choose subtraction constants in the BPHZ scheme.

In order to impose gauge invariance, it is clear from (3.23) that we shall need, in addition to (3.21), the following relations:

$$\begin{aligned}
& \delta \langle 0 | \text{TN}_3 [\bar{\psi}_i \psi_j] (x_{AC})^{\hat{B}\hat{D}} X | 0 \rangle \\
&= u_{ijkl} \langle 0 | \text{TN}_3 [\bar{\psi}_i \psi_j] (x_{AC})^{\hat{B}\hat{D}} X | 0 \rangle \\
&+ u_{k\ell}^{BD} \int dx_{BD} \delta(BD) \langle 0 | \text{TN}_3 [\bar{\psi}_i \psi_j] (x_{AC}) \text{TN}_3 [\bar{\psi}_k \psi_\ell] (x_{BD}) X | 0 \rangle \\
&+ v_{ijkl}^{ACD} \int dx_{ACD} \delta([AC]D) \langle 0 | \text{TN}_3 [\bar{\psi}_k \psi_\ell] (x_{ACD})^{\hat{B}} X | 0 \rangle \\
&\delta \langle 0 | \text{TN}_3 [\bar{\psi}_i \psi_j] (x_{ACD})^{\hat{B}} X | 0 \rangle = u_{ijkl} \langle 0 | \text{TN}_3 [\bar{\psi}_k \psi_\ell] (x_{ACD})^{\hat{B}} X | 0 \rangle \\
&\delta \langle 0 | \text{TN}_4 [\bar{\psi}_i \psi_j] (x_{CD})^{\hat{A}\hat{B}} X | 0 \rangle = u_{k\ell} [\bar{\psi}_i \psi_j] \langle 0 | \text{TN}_4 [\bar{\psi}_k \psi_\ell] (x_{CD})^{\hat{A}\hat{B}} X | 0 \rangle \\
&+ v_{k\ell}^\mu [\bar{\psi}_i \psi_j] \langle 0 | \text{TN}_4 [\partial_\mu (\bar{\psi}_k \psi_\ell)] (x_{CD})^{\hat{A}\hat{B}} X | 0 \rangle \\
&+ w_{k\ell}^\mu [\bar{\psi}_i \psi_j] \langle 0 | \text{TN}_4 [\bar{\psi}_k (\frac{1}{2} \overleftrightarrow{\partial}_\mu - ieA_\mu) \psi_\ell] (x_{CD})^{\hat{A}\hat{B}} X | 0 \rangle \tag{3.24} \\
&+ \left\{ w_{ijkl}^{ACD} \int dx_{ACD} \delta(A[CD]) \langle 0 | \text{TN}_3 [\bar{\psi}_k \psi_\ell] (x_{ACD})^{\hat{B}} X | 0 \rangle + (A \leftrightarrow B) \right\} \\
&\delta \langle 0 | \text{TN}_3 [\bar{\psi}_i \psi_j] (x_{CD})^{\hat{A}\hat{B}} X | 0 \rangle = u_{ijkl} \langle 0 | \text{TN}_3 [\bar{\psi}_k \psi_\ell] (x_{CD})^{\hat{A}\hat{B}} X | 0 \rangle \\
&\delta \langle 0 | \text{TN}_4 [\bar{\psi}_i (\frac{1}{2} \overleftrightarrow{\partial}_\mu - ieA_\mu) \psi_j] (x_{CD})^{\hat{A}\hat{B}} X | 0 \rangle \\
&= u_{k\ell} [\bar{\psi}_i (\frac{1}{2} \overleftrightarrow{\partial}_\mu - ieA_\mu) \psi_j] \langle 0 | \text{TN}_4 [\bar{\psi}_k \psi_\ell] (x_{CD})^{\hat{A}\hat{B}} X | 0 \rangle \\
&+ v_{k\ell}^\nu [\bar{\psi}_i (\frac{1}{2} \overleftrightarrow{\partial}_\mu - ieA_\mu) \psi_j] \langle 0 | \text{TN}_4 [\partial_\nu (\bar{\psi}_k \psi_\ell)] (x_{CD})^{\hat{A}\hat{B}} X | 0 \rangle \\
&+ w_{k\ell}^\nu [\bar{\psi}_i (\frac{1}{2} \overleftrightarrow{\partial}_\mu - ieA_\mu) \psi_j] \langle 0 | \text{TN}_4 [\bar{\psi}_k (\frac{1}{2} \overleftrightarrow{\partial}_\nu - ieA_\nu) \psi_\ell] (x_{CD})^{\hat{A}\hat{B}} X | 0 \rangle \\
&+ \left\{ z_{ijkl\mu}^{ACD} \int dx_{ACD} \delta(A[CD]) \langle 0 | \text{TN}_3 [\bar{\psi}_k \psi_\ell] (x_{ACD})^{\hat{B}} X | 0 \rangle + (A \leftrightarrow B) \right\}
\end{aligned}$$

$$\begin{aligned} & \delta \langle 0 | \mathcal{TN}_3 [\bar{\psi}_i \psi_j] (x_{AC}) \mathcal{N}_3 [\bar{\psi}_k \psi_\ell] (x_{BD}) X | 0 \rangle \\ &= (u_{ijmn} \delta_{kr} \delta_{ls} + \delta_{im} \delta_{jn} u_{klrs}) \langle 0 | \mathcal{TN}_3 [\bar{\psi}_m \psi_n] (x_{AC}) \mathcal{N}_3 [\bar{\psi}_r \psi_s] (x_{BD}) X | 0 \rangle \end{aligned}$$

where u_{ijkl} , $u_{ij}[\mathcal{O}]$, $v_{ij}^\mu[\mathcal{O}]$ and $w_{ij}^\mu[\mathcal{O}]$ are given in (3.2) and (3.14) and v_{ijkl}^{ACD} , w_{ijkl}^{ACD} and $z_{ijkl\mu}^{ACD}$ are special cases of the formulas (3.22).

Combining (3.21), (3.23) and (3.24), we obtain

$$\begin{aligned} & \delta \langle 0 | \hat{\mathcal{T}} \mathcal{N}_3 [A](x_A) \mathcal{N}_3 [B](x_B) \mathcal{N}_4 [C](x_C) \mathcal{N}_4 [D](x_D) X | 0 \rangle \\ &= \left\{ \left[\frac{m_0^4}{m^2+a} \frac{\partial a_{ij}^{AC}}{\partial m_0^2} + a_{kl}^{AC} u_{kl ij} + u_{ij}^{AC} \right] \int d^4 x_{AC} \delta(AC) \langle 0 | \mathcal{TN}_3 [\bar{\psi}_i \psi_j] (x_{AC}) \hat{B} \hat{D} X | 0 \rangle \right. \\ &+ (A \leftrightarrow B) + (C \leftrightarrow D) + (A \leftrightarrow B, C \leftrightarrow D) \left. \right\} \\ &+ \left\{ \left[\frac{m_0^4}{m^2+a} \frac{\partial a_{ij}^{ACD}}{\partial m_0^2} + a_{kl}^{ACD} u_{kl ij} + u_{ij}^{ACD} + a_{kl}^{AC} v_{kl ij}^{ACD} + a_{kl}^{AD} v_{kl ij}^{ADC} + a_{kl}^{CD} v_{kl ij}^{ACD} \right. \right. \\ &+ \left. \left. a_{kl\mu}^{CD} z_{kl ij}^{ACD\mu} \right] \int d^4 x_{ACD} \delta(ACD) \langle 0 | \mathcal{TN}_3 [\bar{\psi}_i \psi_j] (x_{ACD}) \hat{B} X | 0 \rangle + (A \leftrightarrow B) \right\} \quad (3.25) \\ &+ \left[\frac{m_0^4}{m^2+a} \frac{\partial a_{ij}^{CD}}{\partial m_0^2} + a_{kl}^{CD} u_{ij} [\bar{\psi}_k \psi_\ell] + u_{ij}^{CD} + a_{kl}^{CD\mu} u_{ij} [\bar{\psi}_k (\frac{1}{2} \overleftrightarrow{\partial}_\mu - ieA_\mu) \psi_\ell] \right] \\ &\times \int d^4 x_{CD} \delta(CD) \langle 0 | \mathcal{TN}_4 [\bar{\psi}_i \psi_j] (x_{CD}) \hat{A} \hat{B} X | 0 \rangle \\ &+ \int d^4 x_{CD} \left\{ \left[\frac{m_0^4}{m^2+a} \frac{\partial a_{ij\mu}^{CD,C}}{\partial m_0^2} + a_{kl\mu}^{CD,C} u_{kl ij} + u_{ij\mu}^{CD,C} + a_{kl}^{CD} v_{ij\mu} [\bar{\psi}_k \psi_\ell] \right. \right. \\ &+ \left. \left. a_{kl\nu}^{CD} v_{ij}^\nu [\bar{\psi}_k (\frac{1}{2} \overleftrightarrow{\partial}_\mu - ieA_\mu) \psi_\ell] \right] \frac{\partial}{\partial x_{C\mu}} \right. \\ &+ \left. \left[\frac{m_0^4}{m^2+a} \frac{\partial a_{ij\mu}^{CD,D}}{\partial m_0^2} + a_{kl\mu}^{CD,D} u_{kl ij} + u_{ij\mu}^{CD,D} + a_{kl}^{CD} v_{ij\mu} [\bar{\psi}_k \psi_\ell] \right. \right. \end{aligned}$$

$$\begin{aligned}
 & + a_{kl\nu}^{CD} v_{ij}^{\nu} \left[\bar{\psi}_k \left(\frac{1}{2} \overleftrightarrow{\partial}_\mu - ieA_\mu \right) \psi_\ell \right] \left. \frac{\partial}{\partial x_{D\mu}} \right\} \\
 & \delta(CD) \langle 0 | TN_3 [\bar{\psi}_i \psi_j] (x_{CD}) \hat{A} \hat{B} X | 0 \rangle \\
 & + \left[\frac{m_0^4}{m^2+a} \frac{\partial a_{ij\mu}^{CD}}{\partial m_0^2} + u_{ij\mu}^{CD} + a_{kl}^{CD} w_{ij}^{\mu} [\bar{\psi}_k \psi_\ell] + a_{kl}^{CD} v_{ij}^{\mu} \left[\bar{\psi}_k \left(\frac{1}{2} \overleftrightarrow{\partial}_\nu - ieA_\nu \right) \psi_\ell \right] \right] \\
 & \times \int d^4 x_{CD} \delta(CD) \langle 0 | TN_4 \left[\bar{\psi}_i \left(\frac{1}{2} \overleftrightarrow{\partial}^\mu - ieA^\mu \right) \psi_j \right] (x_{CD}) \hat{A} \hat{B} X | 0 \rangle \\
 & + \left(\left[\frac{m_0^4}{m^2+a} \frac{\partial a_{ij}^{AC}}{\partial m_0^2} + a_{mn}^{AC} u_{mnij} + u_{ij}^{AC} \right] a_{kl}^{BD} + a_{ij}^{AC} \left[\frac{m_0^4}{m^2+a} \frac{\partial a^{BD}}{\partial m_0^2} + a_{mn}^{BD} u_{mnkl} + u_{kl}^{BD} \right] \right) \\
 & \times \int d^4 x_{AC} \int d^4 x_{BD} \delta(AC) \delta(BD) \langle 0 | TN_3 [\bar{\psi}_i \psi_j] (x_{AC}) N_3 [\bar{\psi}_k \psi_\ell] (x_{BD}) X | 0 \rangle \\
 & + (A \leftrightarrow B) \left. \right\}
 \end{aligned}$$

Setting the quantities in square brackets equal to zero and referring to (3.23), we obtain, finally, the following differential equations for the coefficients:

$$\begin{aligned}
 \frac{\partial a_{ij}^{AC}}{\partial m_0^2} &= - \frac{m^2+a}{m_0^4} \hat{u}_{ij}^{AC} \\
 \frac{\partial a_{ij}^{ACD}}{\partial m_0^2} &= - \frac{m^2+a}{m_0^4} \hat{u}_{ij}^{ACD} \\
 \frac{\partial a_{ij\mu}^{CD,C}}{\partial m_0^2} &= - \frac{m^2+a}{m_0^4} \hat{u}_{ij\mu}^{CD,C}
 \end{aligned} \tag{3.26}$$

$$\frac{\partial a_{ij\mu}^{CD}}{\partial m_0^2} = -\frac{m_0^2 + a}{m_0^4} \hat{u}_{ij\mu}^{CD}$$

where \hat{u}_{ij}^{AC} , \hat{u}_{ij}^{ACD} , etc. are given by (3.22) with T replaced by \hat{T} , and \hat{A} , \hat{B} , \hat{C} , \hat{D} by $\mathcal{N}_3[A]$, $\mathcal{N}_3[B]$, $\mathcal{N}_4[C]$ and $\mathcal{N}_4[D]$, respectively. As before, the set of equations (3.26) may be integrated order by order, with the m_0 -independent constants of integration fixed by appropriate normalization conditions.

IV. WARD IDENTITIES

A. The Axial Current Ward Identity

The Ward identity for the vector current $N_3[\bar{\psi}\gamma_\mu\psi]$ was derived in Section II. We now wish to apply similar techniques in the case of the axial-vector current, $N_3[\bar{\psi}\gamma_\mu\gamma^5\psi]$.

First of all, the derivative may be brought inside the normal product, raising its degree from three to four:

$$\partial^\mu \langle 0 | \text{TN}_3[\bar{\psi}\gamma_\mu\gamma^5\psi](x)X | 0 \rangle = \langle 0 | \text{TN}_4[\partial^\mu(\bar{\psi}\gamma_\mu\gamma^5\psi)](x)X | 0 \rangle . \quad (4.1)$$

Then, due to the anticommutation of γ^5 with γ^μ and the linearity of the normal product, we obtain

$$\begin{aligned} & \langle 0 | \text{TN}_4[\partial^\mu(\bar{\psi}\gamma_\mu\gamma^5\psi)](x)X | 0 \rangle & (4.2) \\ & = - \langle 0 | \text{TN}_4[\bar{\psi}\gamma^5(\not{\partial} + iM)\psi](x)X | 0 \rangle \\ & \quad - \langle 0 | \text{TN}_4[\bar{\psi}(-\not{\partial} + iM)\gamma^5\psi](x)X | 0 \rangle \\ & \quad + 2M \langle 0 | \text{TN}_4[\bar{\psi}\gamma^5\psi](x)X | 0 \rangle \end{aligned}$$

Application of the equation of motion (2.11) then yields

$$(1+d)\partial^\mu \langle 0 | \text{TN}_3 [\bar{\psi} \gamma_\mu \gamma^5 \psi](x) X | 0 \rangle = 2(M-c) i \langle 0 | \text{TN}_4 [\bar{\psi} \gamma^5 \psi](x) X | 0 \rangle - \sum_{i=1}^m [\delta(x-w_i) \gamma_{w_i}^5 + \delta(x-z_i) \gamma_{z_i}^{5T}] \langle 0 | \text{TX} | 0 \rangle \quad (4.3)$$

The fact that the normal product on the righthand side of (4.3) has degree four instead of three is the famous "anomaly" of Adler, Bell, Jackiw and Schwinger.⁴ The terminology is somewhat misleading, since in renormalized perturbation theory "anomalous" Ward identities are the rule rather than the exception for non-conserved currents. As pointed out in Ref. 7, the Ward identity will have a "normal" righthand side with a normal product of degree three only if there is a conspiracy among several normal products of degree four.

The righthand side of (4.3) may be split into "normal" and "anomalous" terms with the aid of Zimmermann's identity relating normal products of different degree:¹

$$2i(M-c)N_4[\bar{\psi} \gamma_5 \psi] = 2i(M-c)N_3[\bar{\psi} \gamma_5 \psi] + r N_4[F_{\mu\nu} \tilde{F}^{\mu\nu}] + s N_4[\partial^\mu (\bar{\psi} \gamma_\mu \gamma^5 \psi)] \quad (4.4)$$

where

$$r = \frac{i(M-c)}{96} \epsilon^{\mu\kappa\rho\sigma} \left[\frac{\partial}{\partial p^\mu} \frac{\partial}{\partial q^\kappa} \langle 0 | \text{TN}_3 [\bar{\psi} \gamma^5 \psi](0) \tilde{\chi}_\rho(p) \tilde{\chi}_\sigma(q) | 0 \rangle^{\text{PROP}} \right]_{p=q=0}$$

$$s = \frac{(M-c)}{8} (\gamma^5 \gamma^\mu)_{k\ell} \left[\frac{\partial}{\partial p^\mu} \langle 0 | \text{TN}_3 [\bar{\psi} \gamma^5 \psi](0) \tilde{\psi}_\ell(\frac{p}{2}) \tilde{\psi}_k(\frac{p}{2}) | 0 \rangle^{\text{PROP}} \right]_{p=0}$$

The two extra terms on the righthand side come from the extra subtraction prescribed by the N_4 as compared with the N_3 normal product in subgraphs with two external meson and two external fermion lines, respectively. The coefficients

r and s are most simply calculated using the normalization conditions for normal products. An evaluation of r to fourth order is presented in Section V. Inserting (4.4), the axial-current Ward identity becomes

$$\begin{aligned}
 (1+d-s)\partial^\mu \langle 0 | \text{TN}_3 [\bar{\psi} \gamma_\mu \gamma^5 \psi](x) X | 0 \rangle &= 2i(M-c) \langle 0 | \text{TN}_3 [\bar{\psi} \gamma^5 \psi](x) X | 0 \rangle \\
 + r \langle 0 | \text{TN}_4 [F_{\mu\nu} F^{\mu\nu}](x) X | 0 \rangle & \quad (4.5) \\
 - \sum_{i=1}^m [\delta(x-w_i) \gamma_{w_i}^5 + \delta(x-z_i) \gamma_{z_i}^{5T}] \langle 0 | \text{TX} | 0 \rangle.
 \end{aligned}$$

We now wish to re-express Eq. (4.5) in terms of gauge invariant normal products. Actually, the first term on the righthand side is already in gauge-invariant form. To verify this we must show that the coefficient $(1 - \frac{c}{M})$ satisfies (3.12), i.e. that

$$\frac{\partial}{\partial m_0^2} (1 - \frac{c}{M}) = u_5 (1 - \frac{c}{M}) \quad (4.6)$$

where

$$u_5 = -\frac{i}{8} \text{Tr} \gamma^5 \int d^4x \langle 0 | \text{TN}_3 [\bar{\psi} \gamma^5 \psi](x) : (\partial_\mu A^\mu)^2 : (0) \tilde{\psi}(0) \tilde{\psi}(0) | 0 \rangle^{\text{PROP}}. \quad (4.7)$$

and, from (2.23),

$$\frac{\partial c}{\partial m_0^2} = \frac{1}{8} \frac{m^2 + a}{m_0^4} \text{Tr} \langle 0 | \text{T} : (\partial_\mu A^\mu)^2 : (0) \tilde{\psi}(0) \tilde{\psi}(0) | 0 \rangle^{\text{PROP}}. \quad (4.8)$$

Application of (4.5), integrated over all x, to the righthand sides of (4.7) and (4.8) then yields (4.6).

The second term of the righthand member of (4.5) is not gauge invariant, although the coefficient r is independent of m_0 (a simple consequence of the gauge invariance of $(M-c)N_3[\bar{\psi} \gamma^5 \psi]$). From Eq. (3.19) we know that a convenient

gauge invariant linear combination of normal products is

$$\hat{N}_4[F_{\mu\nu}\hat{F}^{\mu\nu}] = N_4[F_{\mu\nu}\hat{F}^{\mu\nu}] + gN_4[\partial^\mu(\bar{\psi}\gamma_\mu\gamma^5\psi)] \quad (4.9)$$

where (see (3.19))

$$\beta = -\int_0^{m_0^2} \frac{m^2+a}{m'^4} (v+\beta u) dm'^2 + \beta^0$$

The constant of integration β^0 must be independent of m_0 , but is otherwise arbitrary. It is most conveniently fixed by a normalization condition on either $\hat{N}_4[F_{\mu\nu}\hat{F}^{\mu\nu}]$ or the axial-vector current. We may now rewrite (4.5) as

$$\begin{aligned} \partial^\mu \langle 0 | \hat{T}j_{5\mu}(x) X | 0 \rangle &= 2M_1 \langle 0 | \hat{T}j_5(x) X | 0 \rangle + r \langle 0 | \hat{T}\mathcal{N}_4[F_{\mu\nu}\hat{F}^{\mu\nu}](x) X | 0 \rangle \\ &- \sum_{i=1}^m [\delta(x-w_i)\gamma_{w_i}^5 + \delta(x-z_i)\gamma_{z_i}^{5T}] \langle 0 | TX | 0 \rangle \end{aligned} \quad (4.10)$$

where

$$\hat{T}\mathcal{N}_4[F_{\mu\nu}\hat{F}^{\mu\nu}]X = \hat{T}N_4[F_{\mu\nu}\hat{F}^{\mu\nu}]X$$

$$\hat{T}j_5 X = T(1 - \frac{c}{M})N_3[\bar{\psi}\gamma^5\psi]X$$

$$\hat{T}j_{5\mu}(x)X = T(1 + d - s - \beta r)N_3[\bar{\psi}\gamma_\mu\gamma^5\psi]X.$$

B. Many-Current Ward Identities

Let us now generalize the Ward identities (2.9) and (4.5) to include an arbitrary number of vector and axial-vector currents. As is well known,⁴ there will be new "anomalies" in the many-current Ward identities due to the presence of renormalization parts containing more than one normal product vertex.

We begin by considering a single divergence of a vector or an axial-vector current. In the former case, Eqs. (2.10) and (2.11) remain valid in the presence of other currents, with the substitution

$$X = \prod_{i=1}^K N_3[\bar{\psi}_\nu \mu_i \psi](x_i) \prod_{j=1}^L N_3[\bar{\psi}_\nu \nu_j \gamma^5 \psi](y_j) \prod_{k=1}^M \psi(w_k) \prod_{\ell=1}^M \bar{\psi}(z_\ell) \prod_{m=1}^N A_{\nu_m}(t_m) \quad (4.11)$$

Thus, once again we have (2.9). By the same token, Eqs. (4.1), (4.2) and (4.3) continue to hold with X given by (4.11). The real complication arises only when we employ the Zimmermann identity to enumerate the various "anomalies". The analogue of (4.4) will not be so simple, since now we must consider subgraphs containing more than one normal product vertex.

Using the abbreviations

$P =$ pseudoscalar $= N_3[\bar{\psi}\gamma^5\psi]$ vertex

$V =$ vector $= N_3[\bar{\psi}\gamma_\mu\psi]$ vertex

$=$ vertex with single external meson line

$A =$ axial-vector $= N_3[\bar{\psi}\gamma_\mu\gamma^5\psi]$ vertex

$F =$ fermion $=$ vertex with single external fermion line

and indicating the number of (momentum space) derivatives by a superscript in parentheses, we may list the possible "anomalies" as follows (the corresponding diagrams are displayed in Fig. 5):

$PVV^{(2)}$, $PPF^{(1)}$, $PAVV^{(1)}$, $PAFF^{(0)}$, $PA^{(3)}$, $PAA^{(2)}$, $PAAA^{(1)}$, $PVVVV^{(0)}$, $PAAVV^{(0)}$, $PAAAA^{(0)}$. The diagrams with an odd number of V vertices have already been

weeded out on grounds of charge conjugation invariance. Of the ten listed possibilities, the last four give vanishing contributions due to considerations of Lorentz invariance, parity and Bose symmetry. Similarly, $PAFF^{(0)}$ gives zero because of parity and charge conjugation invariance, whereas the transversality of $PAVV$ in the momenta entering at both V vertices necessitates the vanishing of the first order Taylor coefficients $PAVV^{(1)}$. Thus the only "anomalies" are of the types $PVV^{(2)}$, $PPF^{(1)}$, $PAA^{(2)}$ and $PA^{(3)}$, of which the first two have already

made their appearance in (4.5). The axial-vector Ward identity now takes the form

$$\begin{aligned}
 \partial^\mu \langle 0 | \hat{T} j_{5\mu}(x) X | 0 \rangle &= 2M_i \langle 0 | \hat{T} j_5(x) X | 0 \rangle \\
 + r \langle 0 | \hat{T} \eta_{4\mu\nu} [F_{\mu\nu}^{\mu\nu}] (x) X | 0 \rangle \\
 - \sum_{i=1}^m [\delta(x-w_i) \gamma_{w_i}^5 + \delta(x-z_i) \gamma_{z_i}^{5T}] \langle 0 | \hat{T} X | 0 \rangle \\
 + \frac{8r}{e^2} \sum_{i < j} \epsilon_{\mu_i \mu_j \rho \sigma} \partial_{x_i}^\rho \partial_{x_j}^\sigma \delta(x-x_i) \delta(x-x_j) \langle 0 | \hat{T} X \widehat{\mu_i} \widehat{\mu_j} | 0 \rangle \\
 - \frac{4r}{e} \sum_i \epsilon_{\mu_i \nu \rho \sigma} \partial_{x_i}^\nu \delta(x-x_i) \langle 0 | \hat{T} F^{\rho\sigma}(x) X \widehat{\mu_i} | 0 \rangle \\
 + \sum_{k < \ell} t \epsilon_{\nu_k \nu_\ell \rho \sigma} \partial_{y_k}^\rho \partial_{y_\ell}^\sigma \delta(x-y_k) \delta(x-y_\ell) \langle 0 | \hat{T} X \widehat{\nu_k} \widehat{\nu_\ell} | 0 \rangle \\
 + \sum_k s_{\nu_k \lambda \mu \nu} \partial_{y_k}^\lambda \partial_{y_k}^\mu \partial_{y_k}^\nu \delta(x-y_k) \langle 0 | \hat{T} X \widehat{\nu_k} | 0 \rangle
 \end{aligned} \tag{4.12}$$

where

$$\sum_A = \begin{array}{l} \text{sum over} \\ \text{axial-vector} \end{array} \text{ vector currents}$$

$$X = \prod_{i=1}^K j_{\mu_i}(x_i) \prod_{j=1}^L j_{5\nu_j}(y_j) \prod_{k=1}^M \psi(w_k) \prod_{\ell=1}^M \bar{\psi}(z_\ell) \prod_{m=1}^N A_{\nu_m}(t_m)$$

and the subscript $\widehat{\mu_i}$ (resp. $\widehat{\nu_j}$) indicates the omission of $j_{\mu_i}(x_i)$ (resp. $j_{5\nu_j}(y_j)$) from the product of fields. Moreover, r is given in (4.4), and

$$\begin{aligned}
 t &= \frac{1}{12} M_i \epsilon^{\nu\lambda\rho\sigma} \left[\frac{\partial}{\partial p^\rho} \frac{\partial}{\partial p^\sigma} \langle 0 | \hat{T} j_5(0) \tilde{j}_{5\nu}(p) \tilde{j}_{5\lambda}(q) | 0 \rangle^{\text{PROP}} \right]_{p=q=0} \\
 s_{\tau\lambda\mu\nu} &= \frac{1}{3} M \left[\frac{\partial}{\partial p^\lambda} \frac{\partial}{\partial p^\mu} \frac{\partial}{\partial p^\nu} \langle 0 | \hat{T} j_5(0) \tilde{j}_{5\tau}(p) | 0 \rangle^{\text{PROP}} \right]_{p=0}
 \end{aligned}$$

V. THE AXIAL-VECTOR CURRENT ANOMALY

In Section IV the coefficient of $\mathcal{N}_4[F_{\mu\nu}^2]$ in the Ward identity of the axial-vector current was given as

$$r = \frac{i(M-c)}{96} \epsilon^{\mu\rho\nu\lambda} \left[\frac{\partial}{\partial p^\rho} \frac{\partial}{\partial q^\lambda} \langle 0 | T N_3 [\bar{\psi} \gamma^5 \psi](0) \hat{A}_\mu(p) \hat{A}_\nu(q) | 0 \rangle^{\text{PROP}} \right]_{p=q=0} \quad (5.1)$$

This quantity has been calculated by several authors⁵ to fourth order, with the result

$$r = \frac{e^2}{(4\pi)^2} + O(e^6) \quad (5.2)$$

In addition, it has been argued,⁵ but not conclusively demonstrated, that all higher order radiative corrections should vanish.

In this section we present a verification of (5.2) using BPHZ methods. We consider this an improvement over traditional techniques due to the fact that no cut-offs are needed and only one integration, the (finite) fermion loop integration is performed.

Only one diagram, the basic triangle, contributes to r in second order:

$$r^{(2)} = \frac{iM}{96} \epsilon^{\mu\rho\nu\lambda} \int \frac{d^4 \ell}{(2\pi)^4} [\partial_\rho^p \partial_\lambda^q R_{\mu\nu}^{(2)}(\ell; p, q)]_{p=q=0} \quad (5.3)$$

$$R_{\mu\nu}^{(2)}(\ell; p, q) = 2\text{Tr} \gamma^5 \frac{i}{\ell - \not{q} - M} \gamma_\nu \frac{i}{\ell - M} \gamma_\mu \frac{i}{\ell + \not{p} - M}$$

Explicit evaluation yields the first term of (5.2).

In fourth order, we have

$$r^{(4)} = \frac{iM}{96} \epsilon^{\mu\rho\nu\lambda} \iint \frac{d^4 \ell}{(2\pi)^4} \frac{d^4 s}{(2\pi)^4} [\partial_\rho^p \partial_\lambda^q R_{\mu\nu}^{(4)}(\ell, s; p, q)]_{p=q=0} \quad (5.4)$$

where

$$R_{\mu\nu}^{(4)} = I_{\mu\nu}^{(4)} - \text{BPHZ subtractions}$$

and $I_{\mu\nu}^{(4)}$ is the Feynman integrand corresponding to the six graphs of Fig. 6 and the corresponding graphs with the charge flow reversed. According to the general theorems of Ref. 3, the integrand is absolutely convergent and we are permitted to make the following convenient choice of integration variables. Routing the external momenta, p and q , through the left- and righthand sides of the triangle, respectively, we assume symmetric integrations in the two loop momenta, integrating first over l and then over s (see Fig. 6). We shall see that separate cancellation of the contributions of $I_{\mu\nu}^{(4)}$ and the BPHZ subtraction terms occurs without the necessity of performing the s integration (however, symmetrization in s will be required). For simplicity, Feynman gauge, $m_0 = m$, will be assumed throughout.

The BPHZ subtraction terms contributing to $R_{\mu\nu}^{(4)}$ are of four types: mass, wave-function, γ^μ -vertex and γ^5 vertex, with coefficients $C^{(2)}$, $MD^{(2)}$, $D^{(2)}$, $F^{(3)}$ and $G^{(2)}$, respectively, where

$$\begin{aligned}
 C^{(2)}(s) &= c^{(2)} - \frac{i}{4} \left(\frac{-i}{2s-m} \right) \text{Tr} \gamma^\tau \frac{i}{s-M} \gamma_\tau \\
 D^{(2)}(s) &= d^{(2)} + \frac{1}{16} \left(\frac{-i}{2s-m} \right) \text{Tr} \gamma^\rho \gamma^\tau \frac{i}{s-M} \gamma_\rho \frac{i}{s-M} \gamma_\tau \\
 F^{(3)}(s) &= f^{(3)} + \frac{e}{16} \left(\frac{-i}{2s-m} \right) \text{Tr} \gamma^\rho \gamma^\tau \frac{i}{s-M} \gamma_\rho \frac{i}{s-M} \gamma_\tau \\
 G^{(2)}(s) &= -c^{(2)} M^{-1} + \frac{1}{4} \left(\frac{-i}{2s-m} \right) \text{Tr} \gamma^5 \gamma^\tau \frac{i}{s-M} \gamma^5 \frac{i}{s-M} \gamma_\tau
 \end{aligned} \tag{5.5}$$

Summing up

$$\begin{aligned}
 R_{\mu\nu}^{(4)} \text{ subtractions} &= -(C^{(2)}(s) + MD^{(2)}(s)) \frac{\partial}{\partial M} R_{\mu\nu}^{(2)}(l;p,q) \\
 &+ (2e^{-1} F^{(3)}(s) - 3D^{(2)}(s) + G^{(2)}(s)) R^{(2)}(l;p,q)
 \end{aligned} \tag{5.6}$$

The identities

$$\begin{aligned} r^{(3)} &= eD^{(2)} \\ C^{(2)} &= -MG^{(2)} \end{aligned} \quad (5.7)$$

and the mass-independence of $r^{(2)}$ then lead to a complete cancellation of the subtraction terms upon integrating with respect to ℓ :

$$\begin{aligned} \frac{iM}{96} \epsilon^{\mu\rho\nu\lambda} \int \frac{d^4\ell}{(2\pi)^4} \left[\partial_\rho^p \partial_\lambda^q R_{\mu\nu}^{(4)} \text{ subt.}(\ell, s; p, q) \right]_{p=q=0} \\ = - (C^{(2)}(s) + MD^{(2)}(s)) \frac{\partial}{\partial M} r^{(2)} = 0 \end{aligned} \quad (5.8)$$

We now turn our attention to the unsubtracted Feynman integrand,

$$\epsilon^{\mu\rho\lambda\nu} \partial_\rho^p \partial_\lambda^q R_{\mu\nu}^{(4)}(\ell, s; p, q) \Big|_{p=q=0}$$

In order to write the various terms in compact notation we introduce the following abbreviations:

$$\begin{aligned} A^{\mu_1 \dots \mu_N}(p) &= \prod_{i=1}^N [(p+M)\gamma^{\mu_i}]^{(p+M)} \\ B^{\mu_1 \dots \mu_m 5\mu_{m+1} \dots \mu_N} &= \prod_{i=1}^m (p+M)\gamma^{\mu_i}]^{(p+M)} \gamma^5 \prod_{j=m+1}^N [(p+M)\gamma^{\mu_j}]^{(p+M)} \end{aligned} \quad (5.9)$$

Observe that

$$\begin{aligned} A^{\mu_1 \dots \mu_{2n}}(p) &\sim \gamma^{\mu_1 \dots \mu_{2n}} (p+M)(M^2-p^2)^n + 2np \gamma^{\mu_1 \mu_2 \dots \mu_{2n}} (M^2-p^2)^n \\ A^{\mu_1 \dots \mu_{2n-1}}(p) &\sim \gamma^{\mu_1 \dots \mu_{2n-1}} (M^2-p^2)^n + 2np \gamma^{\mu_1 \mu_2 \dots \mu_{2n-1}} (p+M)(M^2-p^2)^{n-1} \\ B^{\mu_1 \dots \mu_m 5\mu_{m+1} \dots \mu_{2n}}(p) &\sim \gamma^{\mu_1 \dots \mu_m} \gamma^5 \gamma^{\mu_{m+1} \dots \mu_{2n}} (M^2-p^2)^{n+1} \\ &+ 2[2n - (2n-1) + (2n-2) - \dots + 1] (M^2-p^2)^n \gamma^{\mu_1 \mu_2 \dots \mu_m} \gamma^5 \gamma^{\mu_{m+1} \dots \mu_{2n}} (p+M) \\ B^{\mu_1 \dots \mu_m 5\mu_{m+1} \dots \mu_{2n-1}}(p) &\sim \gamma^{\mu_1 \dots \mu_m} \gamma^5 \gamma^{\mu_{m+1} \dots \mu_{2n-1}} (p+M)(M^2-p^2)^n \end{aligned} \quad (5.10)$$

$$+ 2[(2n-1) - (2n-2) + (2n-3) - \dots + 1](M^2 - p^2)^n \gamma^{\mu_1} \gamma^{\mu_2} \dots \gamma^{\mu_m} \gamma^{\mu_{m+1}} \dots \gamma^{\mu_{2n-1}}$$

where the symbol $\tilde{\approx}$ indicates that terms which vanish upon anti-symmetrization in the μ_i have been dropped.

We must compute the nine contributions corresponding to the Feynman diagrams of Fig. 7. Omitting a common factor, these are ($k \equiv \ell + s$):

$$\begin{aligned} (1) \mu\lambda\rho\nu &= \text{Tr } \gamma^{\tau A \rho}(k) \gamma_{\tau B}^{\nu\mu\lambda 5}(\ell) (k^2 - M^2)^{-2} (\ell^2 - M^2)^{-5} \\ &\tilde{\approx} 8M(k^2 - M^2)^{-1} (\ell^2 - M^2)^{-3} [4k^{\rho} \ell_{\alpha} \epsilon^{\alpha\nu\mu\lambda} - (M^2 - k^2) \epsilon^{\rho\nu\mu\lambda} - 2k^{\rho} k_{\alpha} \epsilon^{\alpha\nu\mu\lambda}] (-i) \\ (2) \mu\lambda\rho\nu &= \text{Tr } \gamma^{\tau A \nu}(k) \gamma_{\tau B}^{\mu\lambda 5 \rho}(\ell) (k^2 - M^2)^{-2} (\ell^2 - M^2)^{-5} \\ &\tilde{\approx} (1) \mu\lambda\rho\nu \\ (3) \mu\lambda\rho\nu &= \text{Tr } \gamma^{\tau B 5}(k) \gamma_{\tau A}^{\rho\nu\mu\lambda}(\ell) (k^2 - M^2)^{-2} (\ell^2 - M^2)^{-5} \\ &\tilde{\approx} 16M(k^2 - M^2)^{-1} (\ell^2 - M^2)^{-3} \epsilon^{\rho\nu\mu\lambda} (-i) \\ (4) \mu\lambda\rho\nu &= \text{Tr } \gamma^{\tau A}(k) \gamma_{\tau B}^{\rho\nu\mu\lambda 5}(\ell) (k^2 - M^2)^{-1} (\ell^2 - M^2)^{-6} \\ &\tilde{\approx} 16M(k^2 - M^2)^{-1} (\ell^2 - M^2)^{-4} [(M^2 - \ell^2) \epsilon^{\rho\nu\mu\lambda} + 4\ell^{\rho} \ell_{\alpha} \epsilon^{\alpha\nu\mu\lambda} - 2\ell^{\rho} k_{\alpha} \epsilon^{\alpha\nu\mu\lambda}] (-i) \\ (5) \mu\lambda\rho\nu &= \text{Tr } \gamma^{\tau A}(k) \gamma_{\tau B}^{\nu\mu\lambda 5 \rho}(\ell) (k^2 - M^2)^{-1} (\ell^2 - M^2)^{-6} \\ &\tilde{\approx} 16M(k^2 - M^2)^{-1} (\ell^2 - M^2)^{-4} [(M^2 - \ell^2) \epsilon^{\rho\nu\mu\lambda} + 6\ell^{\nu} \ell_{\alpha} \epsilon^{\rho\alpha\mu\lambda} - 3\ell^{\nu} k_{\alpha} \epsilon^{\rho\alpha\mu\lambda}] (-i) \\ (6) \mu\lambda\rho\nu &= \text{Tr } \gamma^{\tau A}(k) \gamma_{\tau B}^{\mu\lambda 5 \rho \nu}(\ell) (k^2 - M^2)^{-1} (\ell^2 - M^2)^{-6} \\ &\tilde{\approx} 16M(k^2 - M^2)^{-1} (\ell^2 - M^2)^{-4} [(M^2 - \ell^2) \epsilon^{\rho\nu\mu\lambda} + 4\ell^{\mu} \ell_{\alpha} \epsilon^{\rho\nu\alpha\lambda} - 2\ell^{\mu} k_{\alpha} \epsilon^{\rho\nu\alpha\lambda}] (-i) \\ (7) \mu\lambda\rho\nu &= \text{Tr } \gamma^{\tau A \rho \nu}(k) \gamma_{\tau B}^{\mu\lambda 5}(\ell) (k^2 - M^2)^{-3} (\ell^2 - M^2)^{-4} \\ &\tilde{\approx} 16M(k^2 - M^2)^{-2} (\ell^2 - M^2)^{-3} \ell^{\mu} k_{\alpha} \epsilon^{\alpha\rho\nu\lambda} (-i) \\ (8) \mu\lambda\rho\nu &= \text{Tr } \gamma^{\tau A \nu \mu}(k) \gamma_{\tau B}^{\lambda 5 \rho}(\ell) (k^2 - M^2)^{-3} (\ell^2 - M^2)^{-4} \\ &\tilde{\approx} 2(7) \mu\lambda\rho\nu \end{aligned} \tag{5.11}$$

$$\begin{aligned}
 (9) \mu\lambda\rho\nu &= \text{Tr } \gamma^\tau A^{\rho\nu\mu}(\ell) \gamma_\tau B^{\lambda 5}(k) (k^2 - M^2)^{-3} (\ell^2 - M^2)^{-4} \\
 &= 8M(k^2 - M^2)^{-2} (\ell^2 - M^2)^{-3} [(M^2 - \ell^2) \epsilon^{\mu\nu\rho\lambda} + 8\ell^\rho \ell_\alpha \epsilon^{\alpha\nu\mu\lambda}]
 \end{aligned}$$

Contracting with $\epsilon_{\mu\lambda\rho\nu}$ then yields

$$(n) \equiv i \epsilon_{\mu\lambda\rho\nu} (n) \mu\lambda\rho\nu \quad (5.12)$$

$$\begin{aligned}
 (1) &= 4M(4!) (k^2 - M^2)^{-2} (\ell^2 - M^2)^{-3} (2k \cdot \ell + k^2 - 2M^2) = (2) \\
 (3) &= 16M(4!) (k^2 - M^2)^{-1} (\ell^2 - M^2)^{-3} \\
 (4) &= 16M(4!) (k^2 - M^2)^{-1} (\ell^2 - M^2)^{-4} (M^2 - \frac{1}{2} \ell \cdot k) = (6) \\
 (5) &= 8M(4!) (k^2 - M^2)^{-1} (\ell^2 - M^2)^{-4} ((\ell^2 - M^2) + 3M^2 - \frac{3}{2} \ell \cdot k) \\
 (8) &= 8M(4!) (k^2 - M^2)^{-2} (\ell^2 - M^2)^{-3} (\ell \cdot k) = 2(7) \\
 (9) &= 8M^3(4!) (k^2 - M^2)^{-2} (\ell^2 - M^2)^{-3}
 \end{aligned}$$

Summing over all diagrams contributing to $I_{\mu\nu}^{(4)}$ and integrating with respect to the fermion loop momentum yields

$$\begin{aligned}
 &2 \int d^4 \ell [4(1) + (3) + 3(4) + 2(5) + 4(7) + 2(9)] \\
 &= I_{13} + J_{23} + 2M^2 I_{14} - J_{14} \quad (5.13)
 \end{aligned}$$

where

$$\begin{aligned}
 I_{\alpha\beta}(s) &= \int d^4 \ell [(\ell+s)^2 - M^2]^{-\alpha} [\ell^2 - M^2]^{-\beta} \\
 J_{\alpha\beta}(s) &= \int d^4 \ell [\ell \cdot (\ell+s)] [(\ell+s)^2 - M^2]^{-\alpha} [\ell^2 - M^2]^{-\beta}
 \end{aligned}$$

Application of the "scaling" equation (trivial consequence of dimensional analysis and the above definitions),

$$0 = \left(\frac{1}{2} s^\mu \frac{\partial}{\partial s^\mu} + M^2 \frac{\partial}{\partial M^2} + 2\right) I_{13} = I_{13} + J_{23} + 3M^2 I_{14} \quad (5.14)$$

and the identity

$$J_{14} + M^2 I_{14} = 0 \quad (5.15)$$

lead immediately to the vanishing of (5.13).

Equation (5.15) is most easily verified using a Fourier transformation⁹
(c = irrelevant common factor):

$$I_{14}(x) = c D_1(x) D_4(x)$$

$$J_{14}(x) = c \partial_\mu D_1(x) \partial^\mu D_4(x)$$

with

$$D_\lambda(x) = (2iM)^{2-\lambda} \frac{1}{(\lambda-1)!} K_{2-\lambda}(iM\sqrt{x^2-10})$$

The relation (5.15) then follows from the recursion relations of the modified Hankel functions.

REFERENCES

1. W. Zimmermann, Lectures on Elementary Particles and Quantum Field Theory, Vol. 1, p. 397, Cambridge, M.I.T. Press 1970; J. H. Lowenstein, Phys. Rev. D4, 2281 (1971); For earlier work on normal products, see Zimmermann's bibliography. Of particular relevance to the problem of constructing gauge invariant observables is the work of R. Brandt, Fortschritte der Physik 18, 249 (1970).
2. K. Symanzik, Islamabad lectures, 1968, DESY internal report (1971); C. de Calan, Doctoral Thesis, University of Paris, 1968; W. Zimmermann, Ref. 1; O. V. I. Ogievetskii and I. V. Polubavinov, Sov. Phys. JETP 14, 179 (1962); G. Feldman and P. T. Matthews, Phys. Rev. 130, 1633 (1963); E. C. G. Stueckelberg, Helv. Phys. Acta, 11, 225, 229 (1938), C. de Calan and W. Zimmermann, Lettere al Nuovo Cimento, 1, 877 (1969).
3. N. N. Bogoliubov and D. W. Shirkov, Introduction to the Theory of Quantized Fields, New York, Interscience Publishers, 1959; K. Hepp, Commun. Math. Phys. 2, 301 (1966); W. Zimmermann, Commun. Math. Phys. 15, 208 (1969).
4. S. L. Adler, Lectures on Elementary Particles and Quantum Field Theory, Vol. 1, p. 2, Cambridge, M.I.T. Press, 1970. This review article contains an extensive list of references. See also, J. Wess and B. Zumino, CERN report, submitted to Physics Letters.
5. S. L. Adler and W. A. Bardeen, Phys. Rev. 182, 1517 (1969); E. S. Abers, D. A. Dicus and V. L. Teplitz, Phys. Rev. D3, 485 (1971); B.-L. Young, J. F. Wong, G. Gounaris and R. W. Brown, Phys. Rev. D4, 348 (1971);

- K. Johnson, unpublished report; S. L. Adler, R. W. Brown, J. F. Wong, and B. L. Young, Phys. Rev. D4, 1787 (1971); B. W. Lee and J. Zinn-Justin, private communication.
6. M. Gell-Mann and F. Low, Phys. Rev. 84, 350 (1951).
 7. J. H. Lowenstein, Ref. 1.
 8. J. H. Lowenstein, Commun. Math. Phys. 24, 1 (1971).
 9. I. M. Gel'fand and G. E. Shilov, Generalized Functions, Vol. 1, New York, Academic Press, 1964, p. 365.

ACKNOWLEDGMENTS

We wish to thank K. Symanzik for a number of helpful comments. Much of the research on which this article is based was done at the Institut für Theoretische Physik of the Freie Universität Berlin. One of us (J.H.L.) is most grateful to Professors Theis and Penzlin for their hospitality at the Institute and to Dr. Hartwich of the Aussenkommission for making possible his visit to Berlin.

FIGURE CAPTIONS

Fig. 1. Graphical basis for Eq. (2.11). The various terms on the right-hand side correspond to the different types of vertices at which the line canceled by $(i\cancel{\beta}-M)$ may end: 2-vertex, 3-vertex or external vertex. X stands for an arbitrary set of external lines and $X_{\cancel{j}}$ is X with the j th outgoing fermion line omitted.

Fig. 2. Diagrams contributing to the righthand side of Eq. (3.3). Dashed lines are those of the scalar meson. The double line indicates flow of momentum into the normal product vertex. Canceled external lines are amputated.

Fig. 3. Diagrams contributing to the righthand side of Eq. (3.14). $t^{(1)}$ is the first order Taylor operator

$$\left[1 + p^\mu \frac{\partial}{\partial p'^\mu} + q^\mu \frac{\partial}{\partial q'^\mu} \right]_{p'=q'=0}$$

$$p = \ell - k, \quad q = \ell + k, \quad p' = \ell' - k' \quad \text{and} \quad q' = \ell' + k'.$$

Fig. 4. Diagrams contributing to the righthand side of Eq. (3.21). $t^{(1)}$ is the first order Taylor operator,

$$\left[1 + p_C^\mu \frac{\partial}{\partial p_C'^\mu} + p_D^\mu \frac{\partial}{\partial p_D'^\mu} + q^\mu \frac{\partial}{\partial q'^\mu} \right]_{p_C'=p_D'=q'=0}$$

$$\text{with } p_C + p_D = \ell - k, \quad q = \ell + k, \quad p_C' + p_D' = \ell' - k', \quad q' = \ell' - k'.$$

Fig. 5. Diagrams possibly giving rise to anomalies in a many-current Ward identity.

Fig. 6. Diagrams contributing to $I_{\mu\nu}^{(4)}(\ell, s; p, q)$. Also to be included are the same diagrams with the sense of the charge flow reversed.

Fig. 7. Diagrams contributing to $\left. \partial_{\rho}^p \partial_{\lambda}^q I_{\mu\nu}^{(4)}(\ell, s; p, q) \right|_{p=q=0}$. Here $k = \ell + s$.

Also to be included are the same diagrams with the charge flow reversed and/or with $(\rho\nu)$ interchanged with $(\lambda\mu)$.

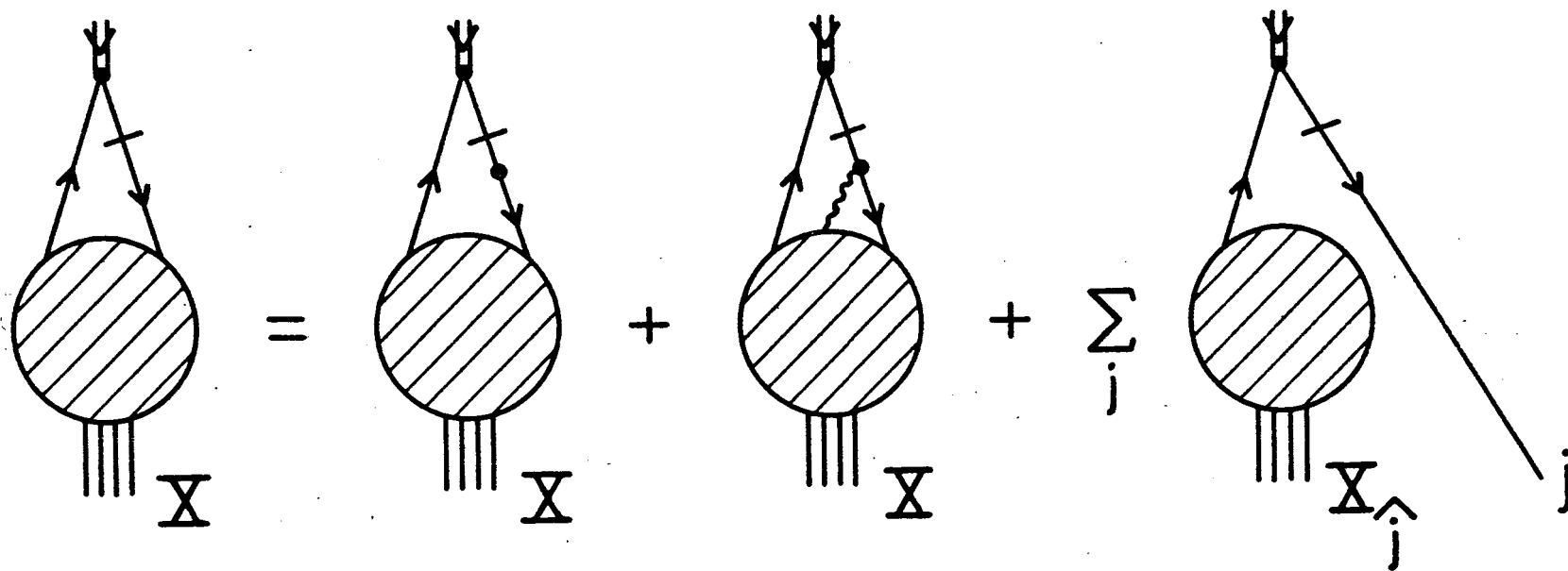

Figure 1

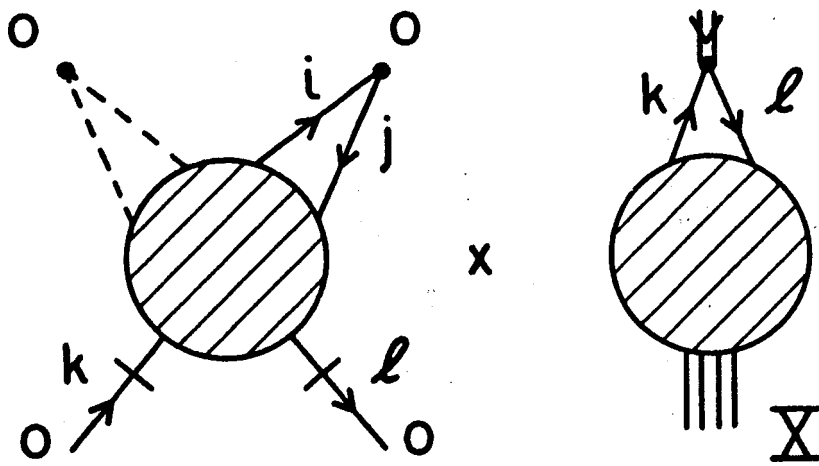

Figure 2

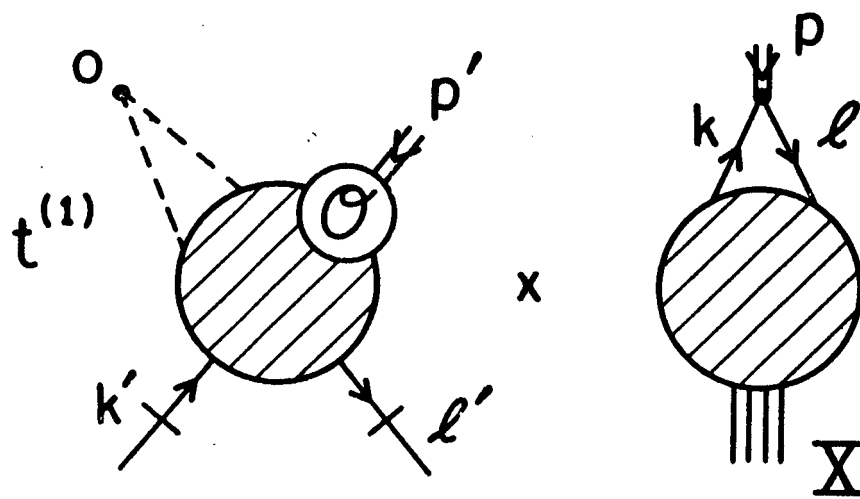

Figure 3a

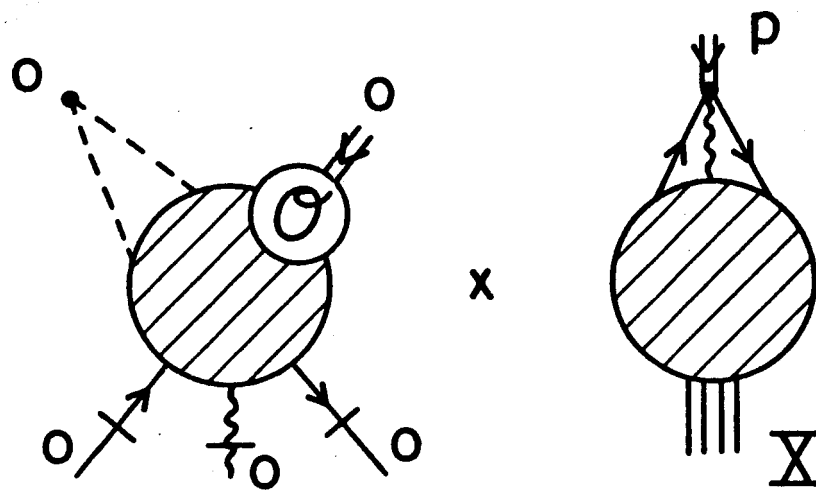

Figure 3b

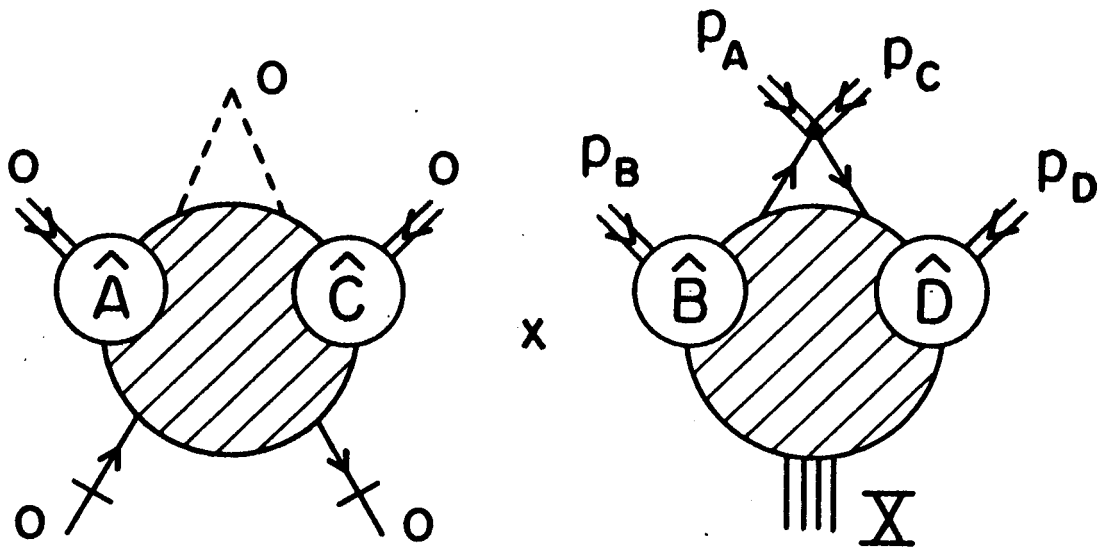

Figure 4a

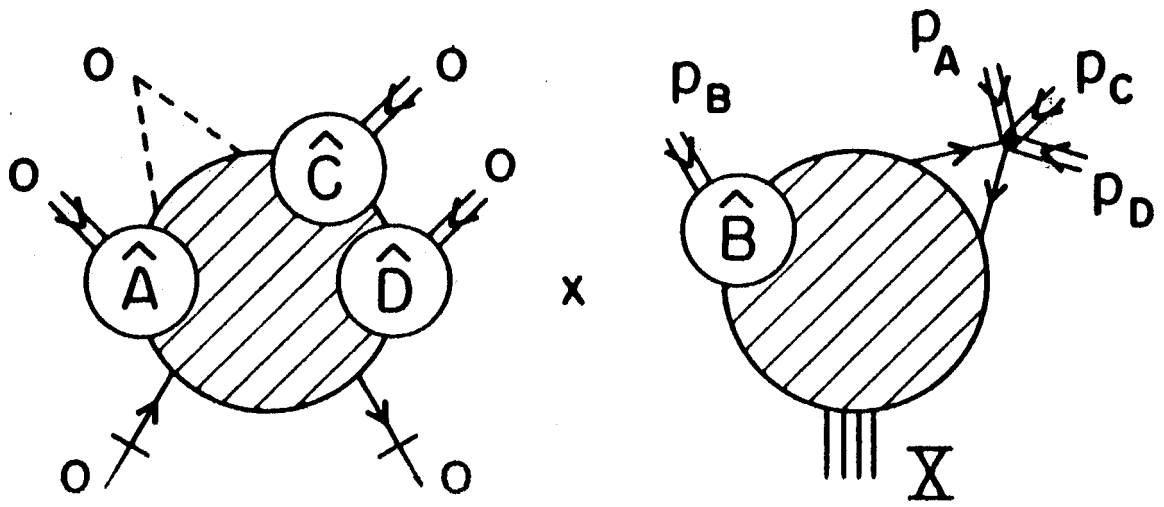

Figure 4b

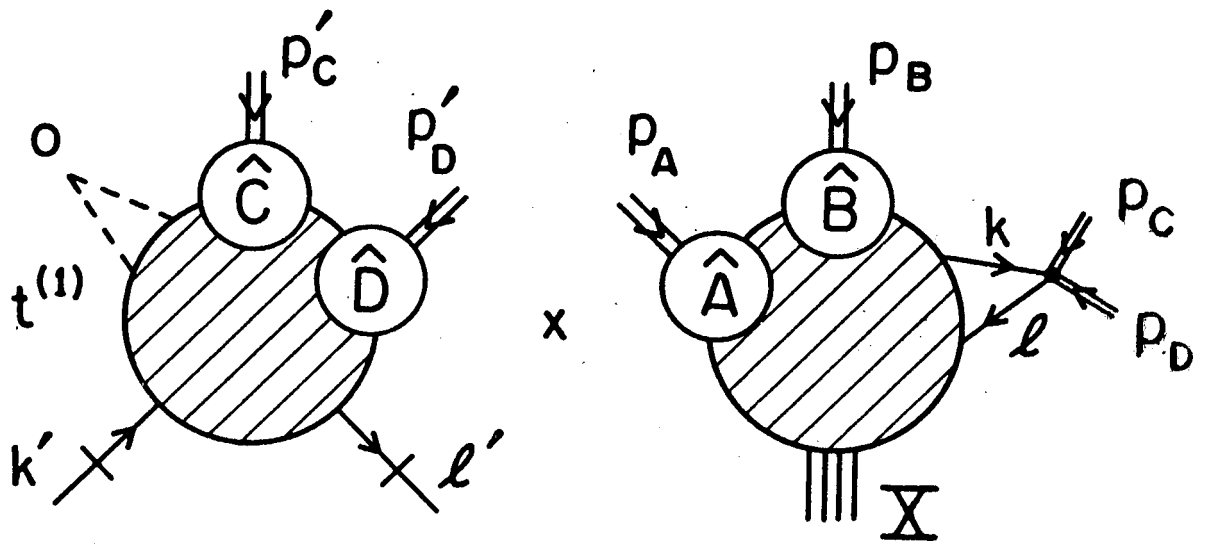

Figure 4c

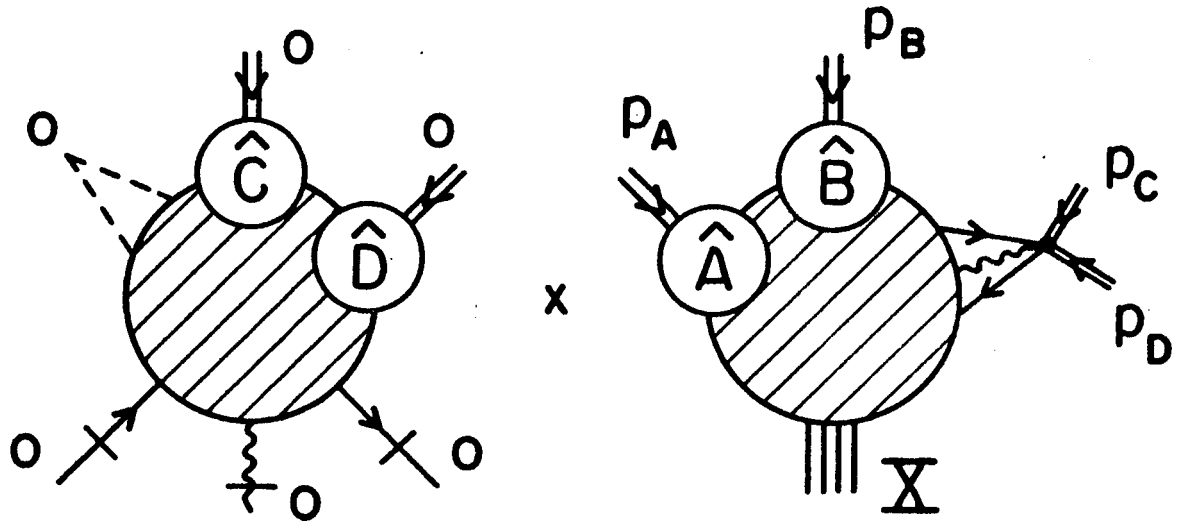
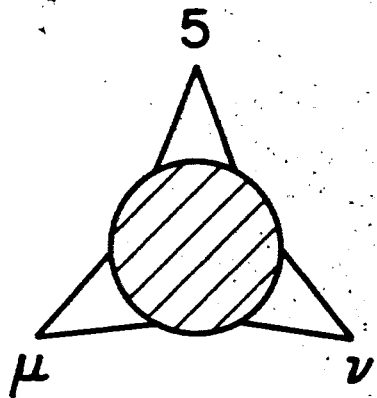
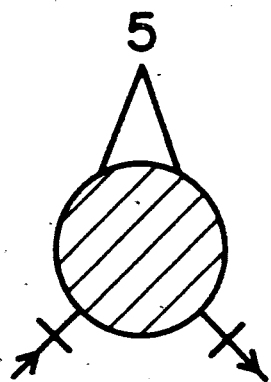

Figure 4d



PVV



PFF

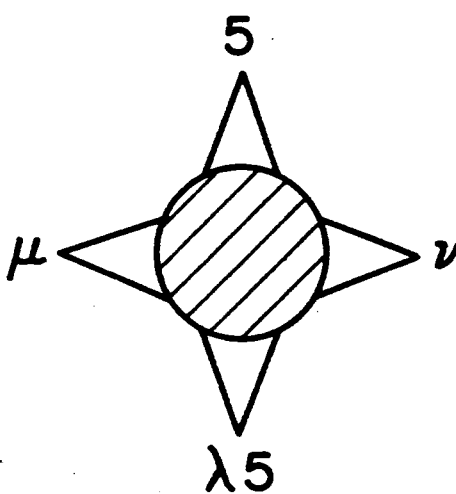

PAVV

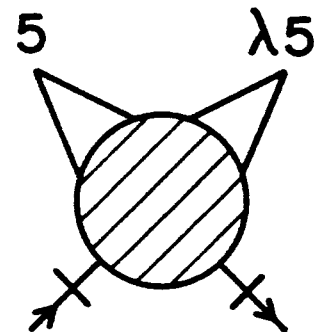

PAFF

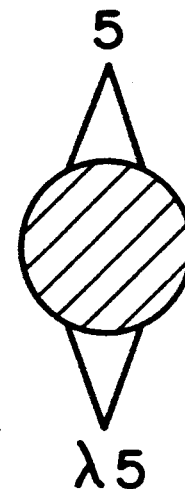

PA

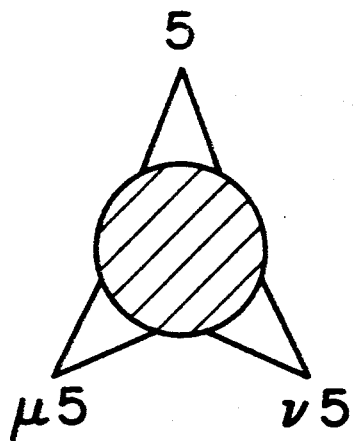

PAA

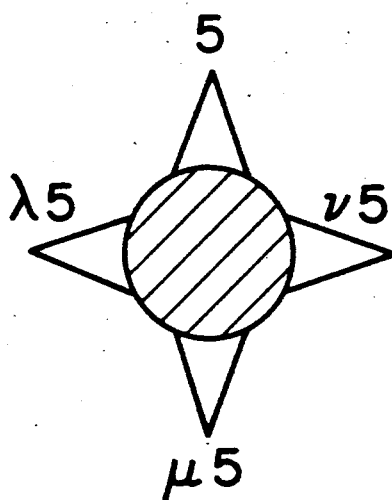

PAAA

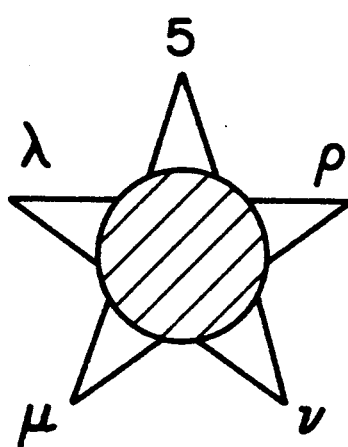

PVVVV

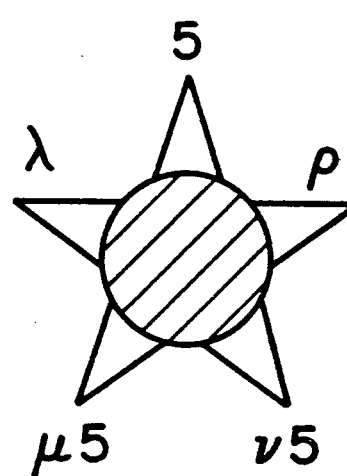

PAAVV

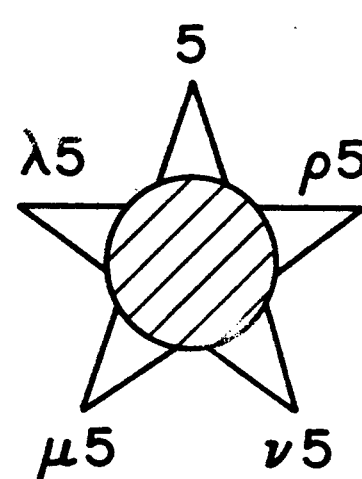

PAAAA

Figure 5

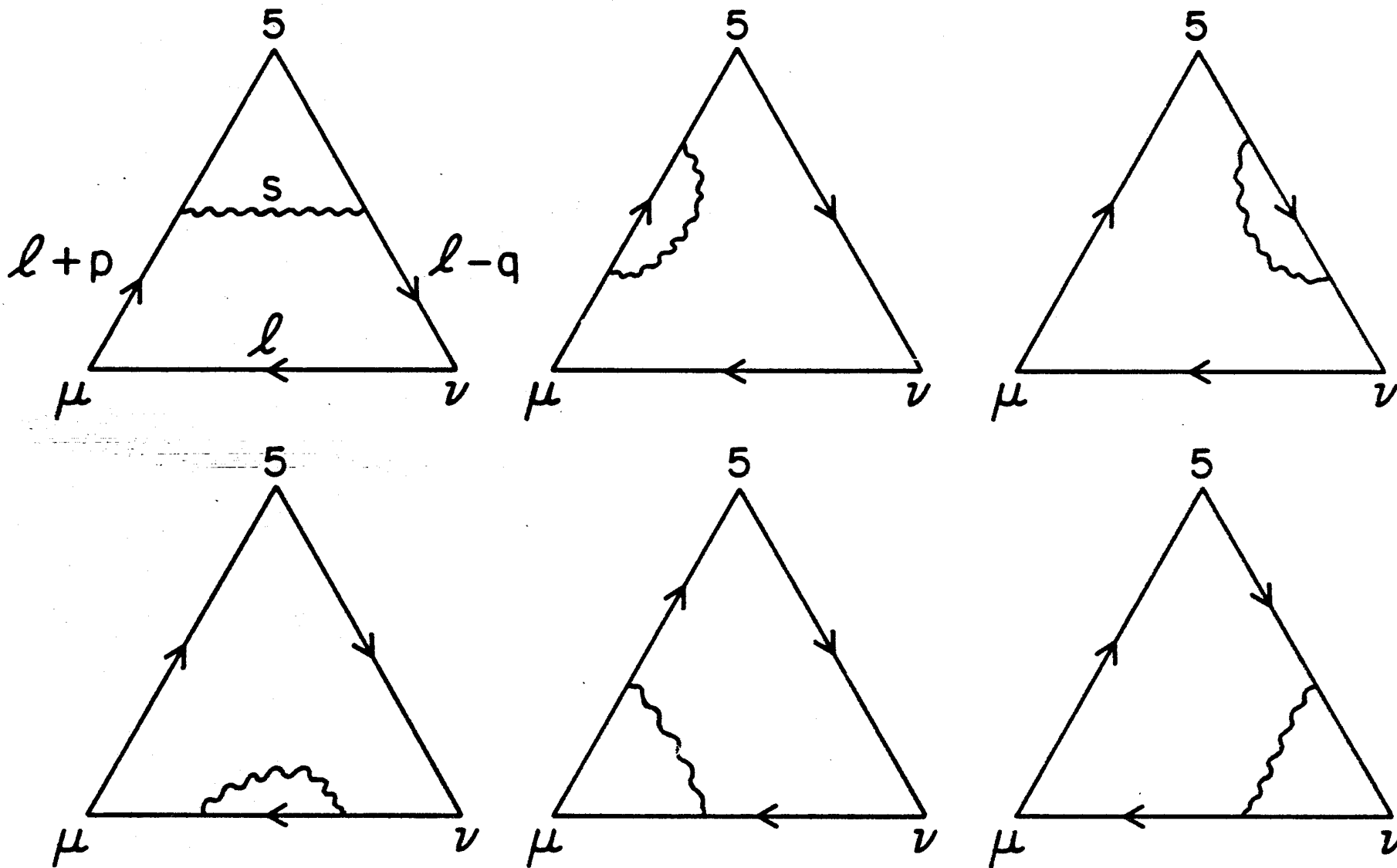

Figure 6

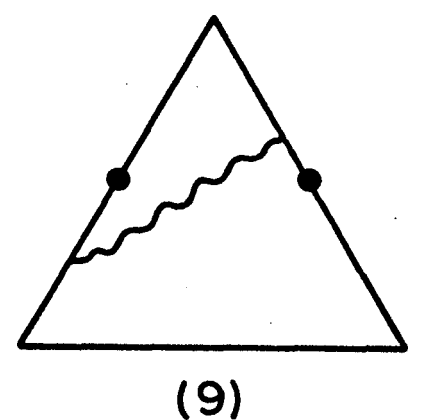
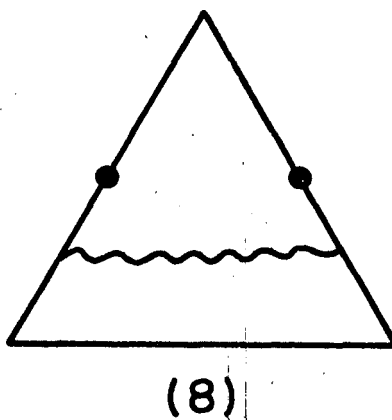
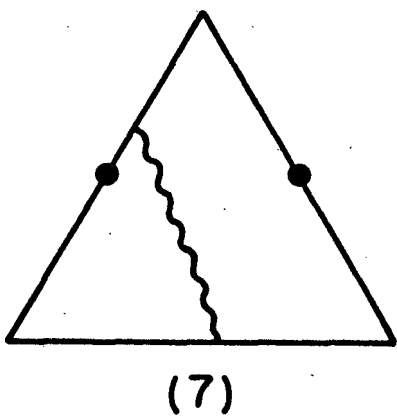
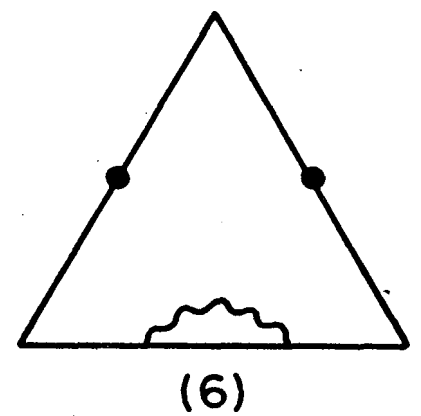
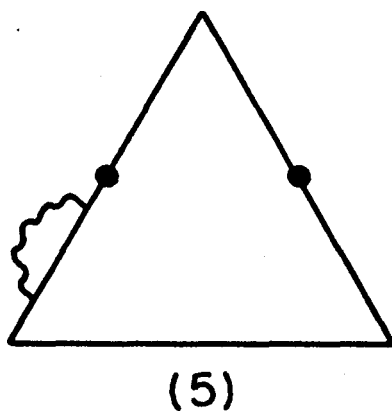
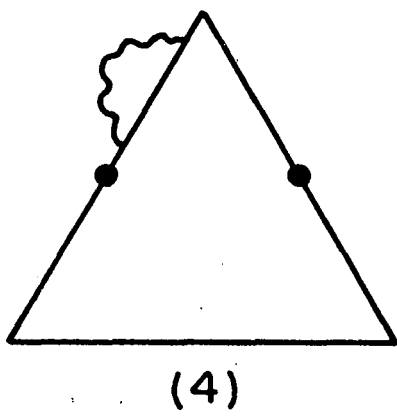
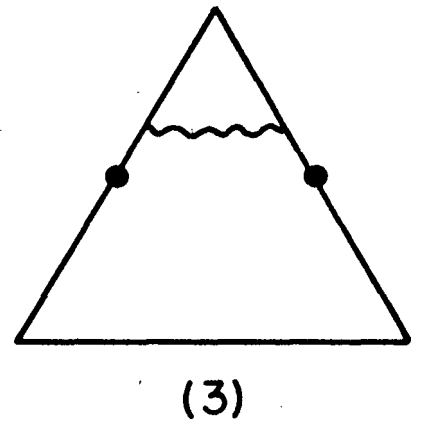
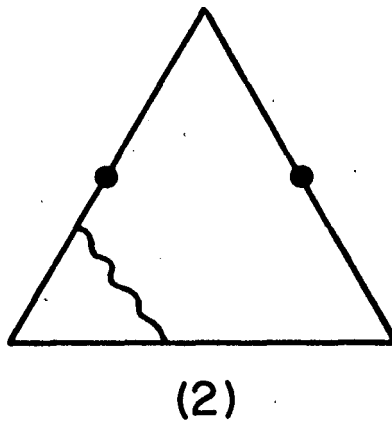
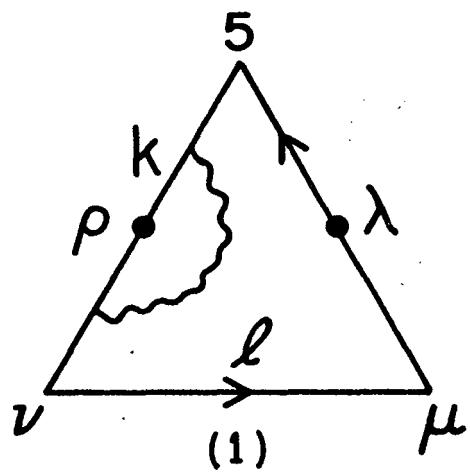

Figure 7