

IAEA-TECDOC-1314

Radionuclide transport dynamics in freshwater resources

*Final results of a Co-ordinated Research Project
1997–2000*



INTERNATIONAL ATOMIC ENERGY AGENCY

IAEA

October 2002

The originating Section of this publication in the IAEA was:

Isotope Hydrology Section
International Atomic Energy Agency
Wagramer Strasse 5
P.O. Box 100
A-1400 Vienna, Austria

RADIONUCLIDE TRANSPORT DYNAMICS IN FRESHWATER RESOURCES
IAEA, VIENNA, 2002
IAEA-TECDOC-1314
ISBN 92-0-113902-0
ISSN 1011-4289

© IAEA, 2002

Printed by the IAEA in Austria
October 2002

FOREWORD

Freshwater contamination due to environmental releases of radioactivity is an issue of global concern. Comprehensive planning of resource protection strategies requires the characterization of radionuclide migration patterns and processes and an ability to simulate these processes in terrestrial and aquatic environments. The IAEA has long been involved in radiological monitoring of aquatic environments for human and environmental protection. Following the Chernobyl accident of 1986, extensive monitoring and analysis of radionuclide migration in surficial environments has been conducted and the results have been published as IAEA publications. Notable publications include: The International Chernobyl Project, Technical Report, 1991 and One Decade after Chernobyl: Summing Up the Consequences of the Accident, IAEA-TECDOC-964. The Inter-Governmental Council of UNESCO's International Hydrological Programme adopted a resolution in 1995 that urged the IAEA to further study the problems of radiological contamination of water resources affected by the Chernobyl fallout. In response to this resolution, and due to its ongoing interest in this area, the IAEA initiated a Co-ordinated Research Project (CRP) in 1997 entitled Radionuclide Migration Dynamics in Freshwater Resources, with a special emphasis on the analysis of Chernobyl fallout migration. Results of the CRP indicate that radionuclides such as ^{90}Sr that commonly occur in the aqueous phase are very mobile within the aquatic environment. Other radionuclides such as ^{137}Cs that strongly interact with the particulate matter suspended in water, with the bottom sediments, and with soil particles show comparatively lower levels of mobility. A study of the vertical migration of Chernobyl radionuclides near Kiev, Ukraine, demonstrates a lack of significant fluxes of radionuclides to groundwater. This report provides a synthesis of the different studies and presents detailed scientific findings of the CRP. It is expected to be useful to scientists, managers and policy makers involved in protection of aquatic and terrestrial resources from radiological contamination.

The IAEA officer responsible for this publication was P. Aggarwal of the Division of Physical and Chemical Sciences.

EDITORIAL NOTE

This publication has been prepared from the original material as submitted by the authors. The views expressed do not necessarily reflect those of the IAEA, the governments of the nominating Member States or the nominating organizations.

The use of particular designations of countries or territories does not imply any judgement by the publisher, the IAEA, as to the legal status of such countries or territories, of their authorities and institutions or of the delimitation of their boundaries.

The mention of names of specific companies or products (whether or not indicated as registered) does not imply any intention to infringe proprietary rights, nor should it be construed as an endorsement or recommendation on the part of the IAEA.

The authors are responsible for having obtained the necessary permission for the IAEA to reproduce, translate or use material from sources already protected by copyrights.

CONTENTS

Summary	1
Radionuclide transport in freshwater systems: A synthesis of the results of the CRP	5
<i>L. Monte, A.I. Klyashtorin, F. Strel, P. Bossew, P. Aggarwal</i>	
¹³⁷ Cs interactions between soil contamination and hydrosphere.....	35
<i>F. Strel, M.H. Gerzabek, K. Kienzl, H. Lettner, P. Bossew</i>	
Forms and dynamics of technogenic radionuclides in the intrasoil flow in forest ecosystems	41
<i>A.I. Shcheglov, A.I. Klyashtorin, G.I. Agapkina, S.V. Mamikhin, O.B. Tsvetnova</i>	
The peculiarities of radiocesium migration in the Nemunas-Neris water system (Lithuania)	77
<i>V. Lujanas, N. Tarasyuk, N. Spirkauskaitė</i>	
Migration of radionuclides in soils and their accumulation in sediments of superficial waters.....	105
<i>St. Chibowski, A. Komosa, M. Reszka, J. Solecki, J. Zygmunt</i>	
Dynamics of the Chernobyl radionuclide migration in cover deposits of Belarus.....	127
<i>V. Kadatsky</i>	
Transport of natural series radionuclides and light rare earth elements in a coastal lagoon of a monazite region	135
<i>D. da Costa Lauria</i>	
Research into specific nature of pollutants migration within subsurface space of large scale industrial and urban agglomerations by isotope techniques	145
<i>V. Gudzenko</i>	
List of Participants.....	161

SUMMARY

A Co-ordinated Research Project entitled Radionuclide Transport Dynamics in Freshwater Resources was initiated by the IAEA in cooperation with UNESCO, to assess radionuclide transport in a range of surface water and shallow groundwater systems. A study involving participants from Austria, Belarus, Brazil, Italy, Lithuania, Poland, Russian Federation, and Ukraine was carried out under the CRP during 1997–1999 aimed at tracing the migration of radionuclides in terrestrial and aquatic ecosystems. The study focused on ^{137}Cs of Chernobyl origin, although the behaviour of other anthropogenic radionuclides (^{134}Cs , ^{238}Pu , $^{239,240}\text{Pu}$, and ^{90}Sr) and several naturally occurring radionuclides (^{212}Bi , ^{228}Ac , ^{214}Bi , ^{226}Ra and ^{40}K) was also investigated in some areas. The study sites included a variety of physiographic, climatic and land use settings to obtain a broad perspective of radionuclide migration characteristics in freshwater environments.

Research conducted within the CRP confirms that mobility of radionuclides through the surface and the groundwater systems is dependent on the physical and chemical properties of the contaminant, and on the rock and sediment characteristics. Radionuclides such as ^{90}Sr that commonly occur in the aqueous phase were found to be very mobile within the aquatic environment. Other radionuclides such as ^{137}Cs that strongly interact with the particulate matter suspended in water, with the bottom sediments, and with soil particles show comparatively lower levels of mobility.

The experimental evidence that was gathered also demonstrates that the horizontal migration of radionuclides through surface waters is of paramount importance. Horizontal radionuclide fluxes in surface water are generally high, and often determine the spatial extent of contamination. In general, vertical migration of radionuclides to the underlying groundwater aquifers is comparatively lower. In fact, soils were found to be effective filters for radionuclide transport to underground water. For example, studies carried out in Belarus and the Russian Federation show that the radiocesium and radiostrontium of Chernobyl fallout are still retained by the upper layers of the soil humus horizon, fourteen years after the accident.

The vertical migration characteristics were found to depend mostly on the contaminant levels and their form (hot particles or aerosols), on the radionuclide in question, on the soil and rock characteristics, and on the hydrological properties of the aquifer. The experimental studies carried out in the framework of the CRP have also demonstrated that the highest ^{137}Cs migration fluxes occur through hydromorphic soils. Radionuclide infiltration through soil to the ground water depends on several factors, such as deposition, depth of the water table, and soil and substrata properties. In automorphic soils, annual infiltration rates of ^{137}Cs at a depth of few decimetres do not exceed 0.005% of the total deposition. Lower infiltration rate is expected for Pu (0.001%), while ^{90}Sr may show infiltration rates one order of magnitude higher than ^{137}Cs . In hydromorphic soils with a well-developed peat layer, the annual infiltration rates of ^{137}Cs at the depth of 0.5 m may reach 0.01% of the total deposition.

It should also be noted that the vegetation cover and soil microbiota may have a strong seasonal and long term effect on radionuclide (primarily ^{137}Cs) mobility and vertical migration through the soil. Field data suggest that up to 40% of the total deposition in hydromorphic forest environments may be immobilized in the living biomass (tree vegetation, fungi mycelium, etc). In automorphic landscapes, the corresponding value is only 13–15%.

A study of vertical migration of Chernobyl radionuclides near Kiev demonstrates a lack of significant fluxes of radionuclides to deep aquifers. However, fast migration of ^{137}Cs to pumping wells may occur through preferential pathways associated with well construction and other human activities.

The above considerations are applicable to radionuclides showing relatively high soil-water partition coefficients such as Cs and Pu isotopes. Other radionuclides, characterized by very low soil-water partition coefficients, can show comparatively higher levels of vertical migration.

Naturally occurring radionuclides can also provide valuable insight into pollutant migration mechanisms in the aquatic environment. The study of the distribution of radium isotopes in the water column of a coastal lagoon in Brazil has shown that factors such as hydrological regime (salinity, pH, etc.) can greatly influence the migration processes.

Predictive models are shown to be valuable tools for improving the scientific understanding of pollutant migration and for planning the necessary actions to reduce the impact of radioactive releases on the environment and on human health. Suitable predictive models must include representation of radionuclide fluxes from the terrestrial environment to the water systems and through the different components of the water bodies. The evaluation of radionuclide fluxes from water to sediment, mainly by deposition of suspended matter, is particularly important for accurately predicting the temporal changes in the contamination levels of water, and has therefore been the object of intensive investigation. Typical values of the ^{137}Cs migration rate constant used in models for predicting the radionuclide behaviour in shallow lakes are of the order of 10^{-7} – 10^{-8} s^{-1} corresponding to radionuclide sedimentation velocity of greater than 10^{-7} m s^{-1} .

Few previous studies have evaluated the direct diffusion of radionuclides from water to sediment, although this process was found to be significant in lakes with negligible sedimentation rates in the present study. “Migration velocity” due to the direct diffusion of ^{137}Cs from the water to lake sediments was estimated at 2.4×10^{-8} to $1.1 \times 10^{-7} \text{ m s}^{-1}$.

The analysis of radionuclide concentrations in river waters contaminated following the Chernobyl accident and from prior nuclear weapon tests in the atmosphere has provided a unique opportunity for assessing the behaviour of radionuclide migration from catchments. The time behaviour of a contaminant flux, following a single pulse deposition of radionuclide, may be described by means of a so-called transfer function (TF). The assessment of the TF offers the opportunity of developing simple and reliable models for predicting the radionuclide migration from catchments. In homogeneous systems it was found that the dominant landscape type can have a considerable influence on the transfer of radionuclides from the catchment to the hydrosphere. In small, forest-dominated catchments containing bogs, ^{137}Cs outflow via surface waters was found to be higher than for similar, agriculturally-dominated catchments. Moreover, the partitioning of ^{137}Cs between the dissolved phase and particulate (suspended) matter phase was different in various surface waters. Overall, higher fluxes of dissolved ^{137}Cs were observed in semi-natural water-flows, attributed to presence of a continuous vegetation cover preventing soil erosion during surface runoff.

New conceptual approaches for modelling the behaviour and the transport of radionuclides through freshwater systems were developed and reviewed within the CRP. It is obvious that the migration of a radionuclide from a catchment is a very complex process that depends on

the varying hydrological and geological characteristics of the constituent parts (sub-catchments) of the drainage area. Radionuclide migration from a large catchment often tends to reflect an integrated average response based on the “ensemble” of physiographic, climatic and land use types that it comprises. “Statistical aggregation” of processes is one approach that may be further developed to model radionuclide migration in large, complex systems. A review of collective models, which are simple and require only a small number of site-specific parameters, suggests that these models may also be useful and adaptable tools for radiation protection and management of freshwater resources.

RADIONUCLIDE TRANSPORT IN FRESHWATER SYSTEMS: A SYNTHESIS OF THE RESULTS OF THE CRP

L. MONTE

ENEA CR Casaccia, Rome

A.I. KLYASHTORIN

Radioecology Laboratory, Faculty of Soil Science, Moscow State University,
Moscow, Russian Federation

F. STREBL

Austrian Research Centre, Seibersdorf, Austria

P. BOSSEW

University of Salzburg, Austria

P. AGGARWAL

International Atomic Energy Agency, Vienna

INTRODUCTION

Environmental releases of radionuclides have occurred over about the last 50 years from a variety of sources, including global fallout, Chernobyl-derived radionuclides, effluents from nuclear installations, and natural radionuclides released as a by-product of mining. A basic understanding of radionuclide distribution and dynamics in lakes and rivers, as well as in their respective catchments, has been gained from experimental studies in different hydrogeologic systems and geographic regions (Nylen and Grip 1997; Burrough et al. 1999; Abraham et al. 2000; Sanchez-Cabeza et al. 2000; Matsunaga et al. 1998; Malmgren and Jansson 1995). The behaviour of radionuclides in soils and sediments has also been the subject of considerable scientific interest and numerous investigations. A range of models useful for predicting radionuclide migration characteristics in soils and sediments also have been developed (IAEA, 2000; BIOMOVs, 1990; Smith et al. 1999; Tipping 1996; Hakanson 1996, 1999; Monte & Hakanson, 1999; Zheleznyak et al., 1992).

Following the Chernobyl accident, a number of projects were launched to validate models for predicting the behaviour of radioactive substances in the environment by using the Chernobyl data. Such projects took advantage of the great deal of experimental data produced after the accident, covering various components of the environment and of the human food chain. BIOMOVs (BIOSpheric Model Validation Study), an international project initiated by the Swedish National Institute for Radiation Protection (NIRP), was the first example of a co-operative study for the validation of environmental models (e.g. BIOMOVs II 1996). The success of the BIOMOVs projects, in terms of new results and in relation to the benefits from the international co-operation, led to the initiation of other validation exercises. In 1990 the project VAMP (Validation of Model Predictions) was sponsored by the IAEA. Among the different tasks of this project, the validation of models for predicting the migration of radionuclides in lakes, reservoirs and rivers has been carried out for some European fresh water systems (IAEA 2000). Both BIOMOVs and VAMP projects stimulated intensive efforts for improving the reliability of the models aimed to predict the migration of ^{137}Cs in lakes and of ^{137}Cs and ^{90}Sr in rivers.

Comparatively few studies have been undertaken, however, on the mechanisms and factors controlling the potential radioactive contamination of groundwater. Recent studies have reported the point-source contamination of groundwater due to leaching of radioactive pollution from underground waste dumps (Kersting et al. 1999; Sloan and Ewen 1999), but the study of groundwater contamination from non-point sources has not been comprehensive. The pathways and processes of vertical migration of radionuclides from superficial catchment compartments (soil and surface water) to groundwater aquifers are not well understood. As a result, a study aimed at tracing the migration of radionuclides, particularly ^{137}Cs resulting from the Chernobyl fallout, in terrestrial and aquatic ecosystems was carried out during 1997–1999 as a Coordinated Research Project (CRP) of the International Atomic Energy Agency (IAEA). The CRP involved participants from Austria, Belarus, Brazil, Italy, Lithuania, Poland, Russia and Ukraine. Besides ^{137}Cs , the behaviour of other anthropogenic radionuclides (^{137}Cs , ^{238}Pu , $^{239,240}\text{Pu}$ and ^{90}Sr) and several naturally occurring radionuclides (^{212}Bi , ^{228}Ac , ^{214}Bi , ^{226}Ra and ^{40}K) was also investigated in some areas. This chapter provides a summary of the objectives, methodology, and results of the various studies. Detailed project reports are attached in the following chapters.

EXPERIMENTAL DESIGN AND LABORATORY TECHNIQUES

Field studies were carried out in several countries covering a variety of geographical (subalpine, lowland, upland) and climatic conditions (mediterranean, continental and subalpine) as well as different types of land use within the catchments (semi-natural, agricultural, urban areas). Main information about participating countries, investigation sites and types of freshwater systems are listed in Table 1. Most field studies deal with the monitoring of artificial radionuclides such as caesium, strontium and transuranic elements. The only non-European investigation site is located in Brazil, focusing on the Radium contamination of coastal waters by naturally occurring monazite ores.

Due to the complexity of the processes involved, each research group focused on specific aspects of the migration of radionuclides in the freshwater environment. The field studies were mainly aimed at investigating the processes controlling radionuclide fluxes to and inside surface groundwater systems. These migration processes can be subdivided into three main categories:

- radionuclide migration to and in surface water environments
- vertical migration of radionuclides from surface groundwater
- radionuclide involvement in biological cycles

At most sites ^{137}Cs of Chernobyl origin was studied. At one of the study sites, other radionuclides of natural origin or from global fallout were considered.

All participants used similar standard analytical methods for the determination of radionuclide contents in the samples (alpha and gamma spectrometry, sometimes with radiochemical separation), but the sampling procedures and preliminary treatment of the samples were different depending on the particular aim of each project (see Table 2).

Austria: The experimental approach was to measure the amount of ^{137}Cs transported by the rivers in particulate, suspended form and in the dissolved fraction of surface water. To estimate the erosion from the catchment, analyses of the sediments in lake Traunsee were carried out. Sedimentation rates were calculated from the analysis of the sedimentary cores by the use of ^{137}Cs as tracer. The study has been carried out in calcareous catchment with high relief energy.

TABLE 1. Experimental sites and types of freshwater systems studied within the CRP

Participating institute	location of investigation site	investigated freshwater system	climatic region	main landuse
Maria Curie-Skłodowska University Lublin/Poland	South-east Poland	Rivers Wieprz, Bug, artificial waterway, lakes	temperate	mixed cropland/ cultivated grassland
Scientific & Engineering Centre for radiohydroecological Investigations (Ukraine)	Kiev region	ground water	temperate/ continental	urban/industrial
State University of Moscow (Russian Federation)	Russian Federation: Kaluga, Tula and Bryansk Regions Ukraine: Kiev region	soil interstitial water (lysimeter)	temperate/ continental	forest
Department of nuclear Physics & Environmental Radioactivity (Lithuania)		river Nemunas, Neris	temperate	
National Academy of Sciences of Belarus (Belarus)	Rodki test area near Minsk	Isloch river catchment and groundwater (16 km ²)	temperate/ continental	40% forest / 55% agricultural
Austrian Research Center Seibersdorf (Austria)	Austria, Waldviertel	catchment of a small river (9 km ²)	upland temperate	seminatural (forest/meadow)
University of Salzburg (Austria)	Austria, Alps	river Traun (> 100 km ²)	temperate mountain	agricultural & meadow/forest
ENEA (Italy)	Central Italy	lakes, rivers	mediterranean	agricultural land
Institute of Radioprotection and Dosimetry Rio de Janeiro (Brazil)	Brazil	coastal lagoon	tropical	seminatural littoral

Sediment sampling was done along river Traun and in some tributaries taking sediments at the surface of the river bed on the river banks. Grain size analysis of the sediments was performed using standard procedures. In lake Traunsee sediments were collected down to depths of 50 cm with a sedimentary corer. Depth distribution of ¹³⁷Cs and history of sedimentation was determined by cutting the sediment cores into slices and subsequent γ -spectrometric analysis. Dissolved and suspended loads were analyzed from surface water samples collected in the middle of a river. Dissolved fraction was analyzed by evaporating a minimum of 60 litres of water. Prior to the analysis, the particulate fraction was removed by gravitational settling over a sedimentation period of 2 months at an ambient temperature of 20°C, and filtering through a 0.45 μ m membrane filter.

At the investigation site Weinsberger Forest, a small upland catchment (9 km²), a comparable experimental design was established: monthly water samples of surface water from 5 subcatchments were separated into liquid and suspended solid phase and gamma-spectrometrically analysed. Information on spatial variability of ¹³⁷Cs soil inventory in the sub-catchments was determined by a rectangular grid sampling design (number of soil cores = 218). By a combination of soil and water data with hydrological information about water flow of the investigated small rivers draining the subcatchments, the loss of ¹³⁷Cs inventory from the catchment via surface water exports could be calculated.

Belarus: The study was carried out in the central part of Belarus, about 50 km NW from Minsk. The key sites were located in the southwest slope of the Belarussian moraine hills (watershed of Nemunas river). The following items were of prime attention: (1) development of criteria for the choice of representative elementary catchments to study radionuclide pathways to river systems; (2) radionuclide spatial and vertical distribution depending on soil and landscape types; (3) contribution of different flows to radionuclide contamination of the river system (structure of the runoff) depending on hydrochemical parameters.

Lithuania: The following items were of particular attention: (1) seasonal balance of ¹³⁷Cs in the Nemunas-Neris water system; (2) physico-chemical forms of ¹³⁷Cs in river water and sediments (river accumulation zone); (3) seasonal dynamics of ¹³⁷Cs infiltration in the sand buffers; (4) Vertical migration of ¹³⁷Cs in the profile of flooded meadow soils in the lower stream of Nemunas river and seasonal dynamics of ¹³⁷Cs in the drainage canals (the rate of soil self-decontamination).

Monthly and single-time samples of river water, sediments and soils were taken at different locations of the investigation area with special attention paid to so-called “accumulation zones“ (enriched with clay-size particles and radionuclides). The samples separated into different particle-size fractions and analyzed for ¹³⁷Cs content.

Italy: The concentrations of ¹³⁷Cs (Chernobyl origin) and of ⁹⁰Sr (from global fallout) in water of some lakes of volcanic origin in Central Italy have been measured since 1986. Data of ⁹⁰Sr concentration in rivers are available since the sixties. As the collected data cover a period of several decades they offer the opportunity of analyzing the long term migration of the above mentioned radionuclides through the respective freshwater environments.

Poland: The valleys of two rivers (Wieprz and Bug) and one artificial waterway (Wieprz-Krzna canal) were chosen and the samples of river bed sediment and soil from the river bank were collected along the rivers. In some points the soil profiles were taken to measure vertical distribution of radionuclides. Three samples were collected at each key point along the investigated rivers using a core sampler of 3.25-inch diameter and 5 cm depth (7 cores were combined to a composite sample). Sediment samples were taken using a core sampler (5 cores were treated as one sample). Gamma (HPGe detector, Silena, Italy,) and alpha spectrometries (PIPS detector, Canberra) were performed. Plutonium isotopes were separated radiochemically before alpha spectrometry measurement.

Russia: The work was carried within the exclusion zone of Chernobyl Nuclear Power Plant (ChNPP) with a range of ¹³⁷Cs deposition from 40 to 0.2 MBq/m². The following items were studied: (1) vertical and horizontal redistribution of radionuclides depending on ecosystem and landscape type; (2) radionuclide forms (in particular radionuclide-organic associations) in the soil liquor; (3) intensity of the biological cycling of radionuclides in forest ecosystems; (4) radionuclide behaviour in the infiltration soil water.

About 500 samples of soil, vegetation, and soil liquors (lysimetrical water) were taken at the key sites in 1998–1999. The samples were analyzed for gamma-emitting radionuclides and partly for ^{90}Sr . Selected soil samples were centrifuged to obtain soil liquors which then were separated into different fractions by molecular weight. The radionuclide content (^{137}Cs , ^{90}Sr , and Pu and Am isotopes) in different fractions was determined.

TABLE 2. Analytical techniques applied by different CRP partners

	Grain size analysis	gamma spect.	Radiochem. Anal.	Chemical Speciation in water	ICP-MS (cation anal.)	Carbon analysis	Alpha spectrometry
Austria	X	X					
Belarus		X					
Brazil		X	X		X	X	X
Italy		X	X				
Poland		X	X				X
Lithuania		X					
Russian Fed.	X (in soils)	X	X	X (in soil liquors)		X	X
Ukraine*		X					

* Additionally had been used: Liquid β -spectrometry for Tritium, selective β -spectrometry for ^{90}Sr in soil and water, α -scintillation techniques for ^{222}Rn and its progeny.

RESULTS AND DISCUSSION

Distribution of radionuclides among environmental components

Spatial distribution of radionuclides

Spatial distribution of radionuclides in terrestrial ecosystems is reported to depend on (1) initial distribution of the radioactive fallout during the deposition event and (2) redistribution of the radionuclides in the course of time. The initial distribution of the radioactive fallout depends on (i) distance from the accidental source; (ii) weather conditions during the initial fallout (“dry and “wet” deposition); (iii) topographical factors, and (iv) vegetation cover in the exposed territory. Further radionuclide redistribution over the contaminated territory is determined by their mobility. In terrestrial environments, the radionuclide mobility depends on type of landscape, local topography, soil and vegetation type, and a number of other factors [Alexakhin, 1977, Shcheglov, 2000].

In all cases but Poland and Italian rivers (Table 3), the investigated technogenic radionuclides are of Chernobyl origin, and the deposition over the investigated territory decreases with the distance from the ChNPP. The deposition in the investigated key sites, however, depends on the intensity of initial fallout of 1986, i.e., on the elevation above sea level, weather conditions at the moment of fallout, etc.

TABLE 3. Main characteristics of the investigation sites

Country	Geographical position of the key site(s)	Investigated radionuclides	Range of deposition	Main source of origin of the radionuclides
Austria	Northern Austria	^{137}Cs	$\sim 50 \text{ kBq/m}^2$	Chernobyl (90%)
Belarus	Belarus, 70 km to the West from Minsk town	^{137}Cs ^{90}Sr	540–560 kBq/m^2 1.2–5.0 Bq/km^2	Chernobyl
Italy	Central Italy	$^{134,137}\text{Cs}$ ^{90}Sr	7–14 kBq/m^2	Chernobyl /Global Global
Lithuania	Nemunas and Neris river basins	^{137}Cs	$\sim 100 \text{ kBq/m}^2$	Chernobyl
Poland	Southeastern Poland	^{137}Cs $^{239, 240}\text{Pu}$ ^{228}Ac , ^{228}Th , ^{212}Bi , ^{226}Ra , etc.	4.3–1.9 kBq/m^2 39–50 Bq/m^2 Variable	Global fallout Global fallout Natural
Russia	Southwestern Russia and northern Ukraine (Kiev oblast)	^{137}Cs ^{90}Sr $^{239, 240}\text{Pu}$	250–30,000 kBq/m^2 20–20,000 kBq/m^2 $\sim 50 \text{ kBq/m}^2$	Chernobyl
Ukraine	Kiev region	^{137}Cs ^{90}Sr ^3H U, Ra, and Rn isotopes	200–200 kBq/m^2 10–100 kBq/m^2	Chernobyl Natural

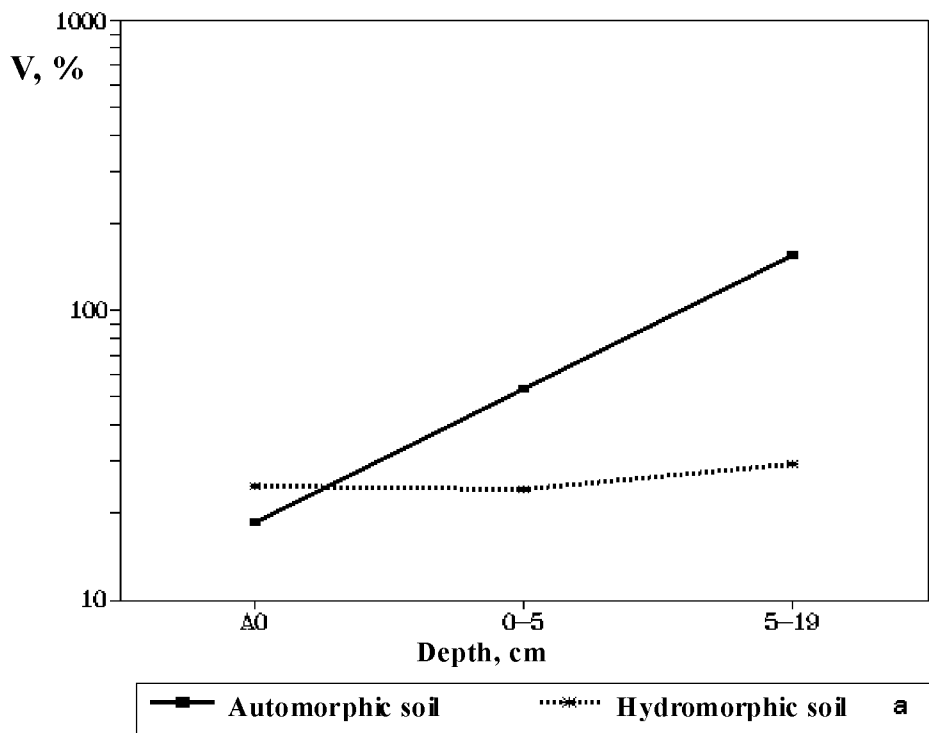

FIGURE 1. Coefficient of variation (V , %) of ^{137}Cs content in the profile of automorphic and hydromorphic soils.

Spatial heterogeneity of the radionuclide content varies down the soil profile, and automorphic and hydromorphic landscapes are different by the manifestation of the variation. In the automorphic landscapes, spatial heterogeneity increases sharply with depth, and the variation coefficient is minimal in the upper horizon (forest litter) (Fig. 2).

The intensity of vertical radionuclide migration in automorphic sandy soils is extremely variable and the downward movement of the radionuclide is not front-like. Thus, the lower boundary of profile distribution of ^{137}Cs is very irregular and radionuclide migration is attributed some local vertical micro-zones with higher conductivity. The radionuclide influx to the ground waters in these microzones is most probable [Scheglov, 2000].

In hydromorphic soil, the increase in the coefficient of variation of ^{137}Cs down the soil profile is insignificant, which is an evidence of the frontal distribution of ^{137}Cs in the soil. This is due to the high moisture [Loshchilov, et al., 1993, Filep et al., 1986], high proportion of soluble organic matter [Agapkina, 1995], and low content of clay minerals, so their cation-absorbing capacity is almost completely limited by ion-exchange mechanisms [Barber, 1988].

In the Austrian catchment Waldviertel the spatial variability of the soil inventory was assessed by rectangular grid sampling (185 sampling points). The coefficient of variation amounted to 36% for mass-related ^{137}Cs results (Bq kg^{-1} in dry soil; 0–15 cm depth), and 27% for area-related ^{137}Cs inventory (Bq m^{-2} ; app. 0–15 cm depth). The good agreement of reported coefficients of variance from the Russian and Austrian catchments are due to the similar land use dominated by seminatural forest.

Distribution of radionuclides among soil and forest living biomass

Biota (including arboreal vegetation, understorey, moos and lichen cover, fungi) is known to be a factor controlling vertical migration of radionuclides through the soils to ground water. A detailed radionuclide partitioning in moderate forest environments was presented in Russian contribution to CRP. It was found that 10–14 years after the fallout, a significant portion of cesium deposition is incorporated in the biota. The specifics of the radionuclide accumulation in various components of forest biomass depend on landscape and soil moisture regime (Tables 4 and 5).

TABLE 4. Distribution of ^{137}Cs among the components of forest ecosystems

Landscape, soil, and vegetation	^{137}Cs content, % of deposition (total inventory)					
	Arboreal vegetation	Herbaceous vegetation	Fungi (incl. mycelium)	Moss cover	Total in vegetation	Total in soil
Eluvial landscape, automorphic sandy soils / mixed forest	4.6	0.12	2.7	0.06	7.48	92.52
Accumulative landscape / hydro-morphic organic-sandy soils / alder forest	12.9	1.67	23.5	5.85	43.92	56.08
Austria, forest stand within Waldviertel catchment (Strebl et al. 1999)	3.3	0.5			3.8	96.2

TABLE 5. Distribution of ^{90}Sr in various forest ecosystem components at Russian sites

Landscape, soil, and vegetation	^{90}Sr content, % of deposition					
	<i>Arboreal vegetation</i>	<i>Herbaceous vegetation</i>	<i>Fungi (incl. mycelium)</i>	<i>Moss cover</i>	<i>Total in vegetation</i>	<i>Total in soil</i>
<i>Eluvial landscape, automorphic sandy soils / mixed forest</i>	11.9	2.4	0.2	no data	7.48	85.5
<i>Accumulative landscape/ hydro-morphic organic-sandy soils / alder forest</i>	19.9	0.6	0.1	no data	43.92	79.4

Vertical distribution of radionuclides in soils

The data presented in Fig. 3 and 4 suggest that the radionuclide distribution in the soil profile varies in both forest and meadow soils depending on the location of the sampling sites. Its mobility is particularly high in Austrian forest soils despite a relatively high proportion of clay in the the mineral soil (app. 25% in fine soil). In contrast to the other investigated forest soils the Austrian site represents a spruce forest with a thick raw humus like litter layer (average thickness of Ol+Of+Oh: 7.5 cm). In Belorussian and Russian soils, the radionuclides migrate much slower, which is likely due to the closer distance from the ChNPP (the main source of pollution for the area). Near the exploded reactor much of the radioactive contamination was deposited at the soil surface as hot particles, in which radionuclides, generated in the uranium crystalline lattice, are bond very strongly. In larger distance from Chernobyl aerosol-transported radionuclides are the main source of pollution. We suppose that the combination of high precipitation (900 mm per year), a thick forest litter layer and the deposition in absence of hot particles in the Austrian forest site lead to faster migration of radiocesium to deeper soil layers.

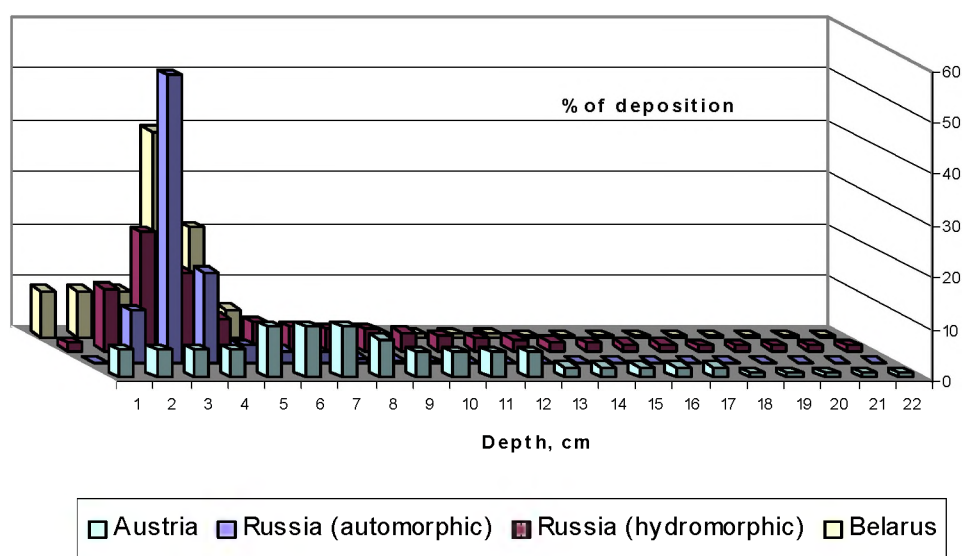

FIGURE 2. Vertical distribution of ^{137}Cs in the investigated forest soils.

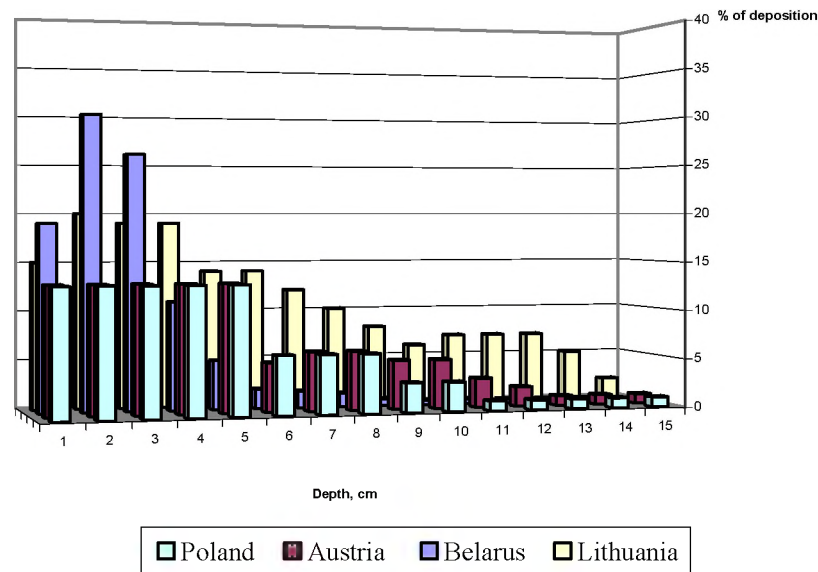

FIGURE 3. Vertical distribution of ¹³⁷Cs in the investigated meadow soils.

⁹⁰Sr in the Belorussian sandy soils is distributed much alike ¹³⁷Cs, which is likely due to the sandy texture of the investigated soils (Fig. 4). The hydrologic regime of the soils shows a very high influence on ⁹⁰Sr migration, which is likely due to much higher proportion of soluble and exchangeable ⁹⁰Sr in the soil, compared to ¹³⁷Cs [Agapkina 1995].

Numerous data on other technogenic radionuclides suggest that these are distributed in the soil profile more or less similar to ¹³⁷Cs, with the maximum in the upper soil layers, though with some specifics due to the nature of each radionuclide. On the contrary, natural radionuclides are rather uniformly distributed down the soil profile (see Poland contribution to CRP), as they were not deposited on the soil surface, but are of natural origin.

In general, the highest rates of radionuclide migration down the soil profile are characteristic for hydromorphic soils (Fig 5). Since hydromorphic soils are typically located in topographical depressions (of various scale), there is a possibility of temporal or permanent contact of a considerable portion of radionuclides with the ground water table. In this case, the rate of radionuclide transport into the “soil–groundwater” system will depend mainly on the coefficient of distribution (k_d -value). As a conclusion of the presented results especially hydromorphic soils represent an important source for the potential contamination of ground water by vertical migration of radionuclides.

Chemical forms of radionuclides in soil

The only direct data on the content of mobile radionuclides in the soil liquor are related to forest soils in the vicinity of the ChNPP (Russian contribution to CRP). Maximum concentrations in the soil liquor were observed for ⁹⁰Sr and ²⁴¹Am, whereas ¹³⁷Cs exhibits only a low solubility (Table 6). Different forms of ¹³⁷Cs mobility in various soil layers are presented in Table 7.

Additional data on forms of plutonium in the soils presented by Poland participants suggest that about 25% of plutonium is exchangeable and readily available, 7% is bound with carbonate fraction, 10% with the sesquioxide fraction, 27% with the organic fraction, and 32% is represented by unextractable residues (Komosa, 2001). A considerable share of radionuclides in the soil liquor (water-soluble fraction) is bound to soluble organic matter of various molecular weight. Its quantitative proportion depends on the nature of radionuclide [Agapkina, 1995].

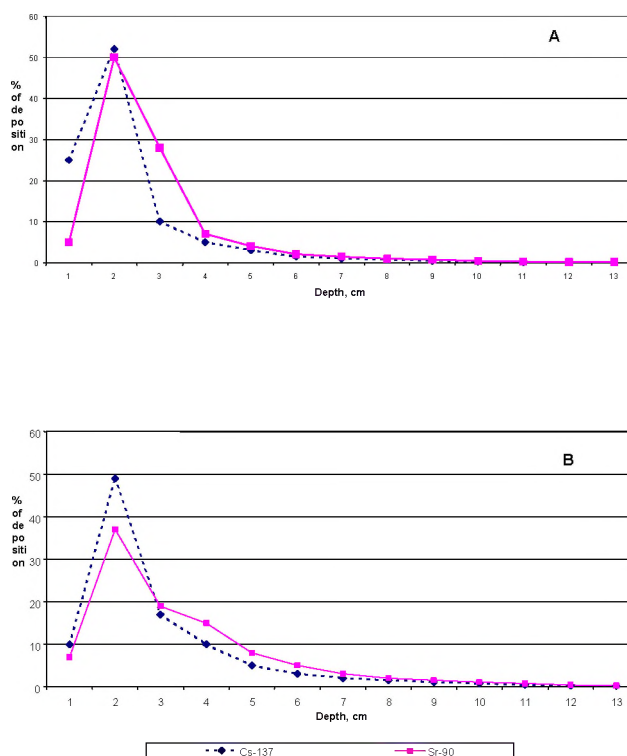

FIGURE 4. Vertical distribution of ¹³⁷Cs and ⁹⁰Sr in (A) automorphic and (B) hydromorphic soils. Key plots 1 and 2, respectively (1998).

TABLE 6. Relative content of dissolved radionuclides in the soil liquors of forest soils (% of average content in the layer 0–20 cm)

⁹⁰ Sr	¹³⁷ Cs	²³⁹⁺²⁴⁰ Pu	²³⁸ Pu	²⁴¹ Am
0.65	0.14	0.066	0.063	0.045

TABLE 7. Forms of ¹³⁷Cs in different soil layers from Russian experimental forest sites (% of average radionuclide content in the horizon)

Horizon	Water soluble	Exchangeable (Ac-NH4)	Potentially available (6N HCl)	Residues (unextractable)
Forest litter	0.05–0.02	0.1–0.5	up to 50	up to 40
Mineral soil	1–2	1–5	up to 30	up to 50

^{90}Sr is present in the soil liquors as low-molecular radionuclide-organic complex and in inorganic (ionic) form. About 30% of ^{137}Cs and almost 90% of Pu in the soil liquor are bound with organic molecules. The data confirm a significance of soluble organic matter as a factor of radionuclide mobility in soils. Soils of hydromorphic areas as a rule are rich of organic matter including soluble organic compounds, which promote radionuclide migration (Nylen & Grip, 1997).

Partitioning of radionuclides in surface and ground waters

Concentration of ^{137}Cs and ^{90}Sr was assessed in several kinds of surface waters, whereas results from groundwater analysis are available for the region of Kiev and well water of Belarus (Table 8).

Results from river water of different geographic regions cover a range between 57 mBq/l ^{137}Cs in Belarus to 0.41 Bq/l in the Austrian river Traun. Results from Lithuanian and Austrian upland river sites are intermediate. The partitioning of radiocaesium between solid phase (i.e. suspended sediment fraction) and dissolved phase is quite comparable for Belarus, Lithuania and the Austrian upland river catchment: between 62 and 83% of total ^{137}Cs activity is dissolved in water, and only a minor share is associated with the particulate fraction of water samples. For the Traun river, getting inflows from a large partly calcareous mountain landscape, the main part of ^{137}Cs is fixed to suspended particles, and only 24% of activity were found in dissolved form. This fact could be explained by differences in landuse: a higher occurrence of agriculturally used land and consequently a higher risk of soil erosion than in continuously vegetated forest or meadow landscapes can be found in the Traun river catchment area. The dissolved fraction of ^{90}Sr in water samples comprises nearly 100% in both Belorussian (river) and Italian (lake) surface water samples.

The contamination of well water from Belarus is exceptionally high (approximately 6 Bq per litre), samples of Ukrainian wells from the Kiev region contained considerably lower ^{137}Cs concentrations (three orders of magnitude: app. 6.6 mBq per litre; see Tab. 7). As only marginal amounts of suspended particles are normally present in well water, nearly the total activity of both ^{137}Cs and ^{90}Sr was found in the liquid phase in dissolved form.

Migration processes and fluxes

Radionuclide fluxes in biological cycle

Biota has high importance as a retarding factor of radionuclide migration due to uptake and storage of elements in the living biomass. In general, the components of biota may be ranked by their capacity for cesium accumulation as follows: mycobiota > mosses > tree layer > herbaceous vegetation and shrubs. The contribution of mycobiota depends on both landscape and ecosystem factors and increases in the range: pine forests > hydromorphic areas > automorphic areas. Soil mycobiota (fungi complex) is therefore one of the most significant factors of radiocaesium retention by forest litter [Shcheglov, 2000].

Throughfall (crown water) and stem flow make insignificant contribution to ^{137}Cs migration through the ecosystem as a whole (both constitute about 0.05% of total deposition per year), but may be of importance in terms of radionuclide fluxes. E.g., this value is comparable with annual rate of ^{137}Cs infiltration from the forest litter and annual root uptake to the overstorey in hydromorphic areas [Shcheglov, 2000].

TABLE 8. Radionuclide contamination (mBq/l) and partitioning between solid and dissolved phase of water samples in different types of surface and groundwater

	¹³⁷ Cs mBq/l		¹³⁷ Cs %		⁹⁰ Sr mBq/l		⁹⁰ Sr %	
	dis-solved	solid phase	dis-solved	solid phase	dis-solved	solid phase	dis-solved	solid phase
river Belarus	57	11	83.5	15.5	4565	13	99.7	0.3
well water Belarus	6200	12	99.8	0.2	2460	15	99.4	0.6
spring water Belarus	40	12	76.9	23.1	2790	45	98.4	1.6
rivers Austria WF (mean of total n=54)	6.4 ± 1.6	3.5 ± 1.4	62.5 ± 11.5	37.5	n.d.	n.d.	n.d.	n.d.
river Traun Austria (n=9)	0.41 ± 0.44	1.28 ± 1.16	24	76	n.d.	n.d.	n.d.	n.d.
lake Italy			95	5			> 99	< 1
Ukraine/Kiev spring water	286							
Ukraine/Kiev drainage adits	5.7							
Ukraine/Kiev wells K2cm	6.4				1.78			
Ukraine/Kiev wells J2bj	6.8				3.22			
mean of quarternary aquifer groundwaters (n=10)	10.13 ± 4.1				9.77 ± 11.1			
mean of eocenic aquifer groundwaters (n=10)	4.61 ± 2.05				0.604 ± 0.47			
Lithuania Nemunas river basin average of season and sampling sites, n=15	1.44 ± 1.0	0.64 ± 0.5	70.3 ± 21.2	29.7				
Lithuania Neris river basin average of seasons (n=4)	3.78 ± 3.1	0.95 ± 0.92	81.3 ± 18.3	18.7				
Brazil Lagoon water	²²⁸ Ra (mBq/l)		²²⁶ Ra (mBq/l)					
min - max dependent on distance from shore	100–1600		100–400					

These findings are only valid for the description of medium- to long term behaviour of deposited radionuclides; shortly after a deposition event the situation may be dramatically different (e.g. in the first weeks afterwards large amounts of intercepted fallout are washed off from the canopy and reach the forest floor with throughfall/stemflow water).

Vertical radionuclide fluxes through soil

Vertical intrasoil flow is the part of soil water that filters down through the soil profile and represents the most mobile component of the soil liquor. Direct information on radionuclide mobility and transport to ground water was obtained by lysimetric studies [Klyashtorin, 1994] in Russian forest environments (Table 9).

TABLE 9. ^{137}Cs transport by infiltration through forest soil (annual mean for 1998) from lysimetric studies in Russian forest environment (Klyashtorin, 1994)

Plot/Deposition (kBq/m ²)	Depth (cm)	Percolated water (l/m ² /y)	Concentration (Bq/l)	Sorption in the layer (%)*	Output Bq/m ² /y	Output (% of layer total)
Hydromorphic / 146 kBq/m ²	0–20	182.1	0.85 ±0.12	21.2	155	0.11
Automorphic / 1902 kBq/m ²	0–20	88.9	5.30 ±0.57	71.3	497	0.026
Automorphic/ 21383 kBq/m ²	0–30	124.7	5.60 ±0.77	97.1	698	0.003

* % of the concentration in the soil water from layer 0–5 cm.

Automorphic sandy soils serve as an effective filter for infiltrating ^{137}Cs : even under extreme deposition (more than 20 MBq/m²), the concentration of ^{137}Cs in the lysimetric water from the 30–cm layer does not exceed 8 Bq/l. Hydromorphic peat soils are much less effective in this respect. In general, a very small portion of total ^{137}Cs deposition is transported below the depth of 30 cm by the intrasoil flow (Table 10). The average annual flux of ^{137}Cs with intrasoil flow from the layer 0–20(30) cm varies from 0.08 to 0.11% depending on soil type. The highest flux was determined for hydromorphic soils, which can be related to the combined effect of intensive leaching in the forest litter, a low sorption capacity, and intensive annual water flux through the hydromorphic soil.

Hence, hydromorphic landscapes are likely to provide some radionuclide flux to local ground water. The potential annual influx of caesium from sandy soils to the upper water table from hydromorphic areas is less than 0.03–0.01% of the total deposition (see Tab. 9; assuming the water table is at a depth of 0.5–1 m). In this case the absolute rate of Cs migration to ground waters even from the less contaminated territories (150 kBq/m²) is about 40 Bq/m²/y.

TABLE 10. Comparison of relative radionuclide outflux with infiltration water from different soil layers (1997)

Layer (cm)	OUTFLOW FROM THE LAYER (% of total deposition)				
	¹⁴⁴ Ce	¹⁰⁶ Ru	¹³⁷ Cs	⁹⁰ Sr	²³⁸⁺²⁴⁰ Pu
Automorphic landscape, mixed forest					
0–5	0.078	0.095	0.087	0.11	0.076
0–10	0.003	0.031	0.004	0.03	0.005
0–20	0.001	0.019	0.002	0.03	0.003
0–30	no data	0.014	0.003	0.02	0.001

It must be emphasized that ^{137}Cs is reported to be the least mobile of all radionuclides but ^{144}Ce . By contrast, ^{90}Sr has about 5–10 times higher mobility, and outflux (Table 10). It may be assumed that at least 0.05% of total deposition of both ^{137}Cs and ^{90}Sr may come annually to the ground water in hydromorphic landscapes.

Lateral fluxes in terrestrial environments

Lateral migration of radionuclides in terrestrial environments is of importance in terms of (i) a potential radionuclide migration from the catchments to water bodies and (ii) possible concentration of radionuclides in the so-called critical zones (river valleys and/or plate-like local depressions) in the course of time. The latter is a potential contamination source of ground and surface waters.

Direct field studies undertaken in the frame of CRP revealed no significant changes in the deposition of ^{137}Cs and ^{90}Sr for the period 1986–1999. The difference between ^{137}Cs deposition in the soils of adjacent, geochemically joint landscapes varied within the range of statistical variability. The rate of annual inter-landscape redistribution of ^{137}Cs in Ukraine at the scale of kilometres was estimated to be about 1% [Shcheglov, 1996, 2000].

The radionuclide redistribution at the scale of meso-topography (tens of meters at the horizontal scale and meters at the vertical scale) is more pronounced. With slopes of 15° and steeper, and height differences of 2–3 m, the differences in radionuclide inventory may reach 50–100% (up to 250 % for ^{106}Ru) (Table 11).

Maximum radionuclide accumulation takes place in the marginal areas of the concave topographical elements, e.g., slope basement. Some authors believe that lower radionuclide content in the central areas of depressions is due to more intensive radionuclide loss via infiltration [Bolyukh, 1996, Shestopalov, 1996]. The intensity of radionuclide redistribution within the elementary landscapes at the scale of meso- and micro-topography is more evident and reaches 10% per year, with a corresponding enrichment of radionuclides in the adjacent depressions.

These findings, namely a radiocesium loss from hillslopes and re-deposition on the valley floor and in local depressions, agree with results from Tyler and Heal (2000), who modeled radionuclide redistribution within an upland catchment by use of a GIS based topographic / hydrological model taking into account both particulate and solute transport of ^{137}Cs .

Migration from catchment to water bodies

The radionuclide influx to the surface and ground water sources is much less intensive compared to the rate of radionuclide redistribution within terrestrial environments, since most of the radionuclides are normally retained in the accumulative areas, such as the river valleys, lake depressions, etc.

TABLE 11. Range of ^{137}Cs soil inventory in adjacent, geochemically joint meso-topographical landscape elements ("near zone", 1991, means of n=15)

Micro-topographical element	Radionuclide					Total
	^{144}Ce	^{134}Cs	^{137}Cs	^{106}Ru	^{90}Sr	
	Relative units					
Top of a sand ridge	100	100	100	100	100	100
Slope of a sand ridge	108.9	113.3	99.7	158.3	138.4	111.8
Slope basement	140.0	176.7	162.5	100	167.0	162.1
Bottom of the adjacent depression	133.3	136.7	134.8	237.5	114.3	135.1

^{137}Cs transport from a flat catchment to adjacent small rivers in Belarus is estimated as 0.034% of total deposition per 15 years, which averages to about 0.002% per year (see Belarusian contribution to CRP).

This value is higher in regions with steeper topography: the data provided by Austrian participants suggest the rate of caesium transport from the catchments to the lake is about 0.015% per year. Almost 100% of the transported caesium is bound with solid particles, which supports the assumption of surface erosion as an important factor of radiocaesium migration from catchments to surface waters.

The experimental data presented by Italian participants are related to the migration of “global” ^{90}Sr in a large basin (hilly/mountain landscapes of Central Italy). The estimated annual rate of ^{90}Sr transport from the catchment and the corresponding transport by the Tiber river and is about 0.04% per year. Since the mobility of strontium is known to exceed the mobility of Cs, this high rate is quite explainable.

Many studies have been undertaken in recent years on the quantitative assessment of radionuclide migration from catchments (Hilton et al., 1993; Santschi et al., 1990; Smith et al., 2000, Sundblad et al., 1991, Monte, 1995).

The migration of radionuclides from catchments to water bodies is due to the transport of radionuclides both in particulate and dissolved forms.

The process of the radionuclide absorption to solid particles is usually modelled according to the well known partition coefficient (k_d) approach based on the hypothesis of a reversible equilibrium between the dissolved and the adsorbed phases of radionuclide. The amount of radionuclide migrating from the drainage area to a water body can be evaluated as a function of the amount of the eroded particle and the dissolved radionuclide concentration (C_w) in runoff waters:

$$P = C_w k_d W_{sm} \Phi \quad (6)$$

where P is the radionuclide flux in particulate form (Bq s^{-1}), Φ is the water flux ($\text{m}^3 \text{s}^{-1}$) and W_{sm} the amount of eroded particles per cubic metre of water body (kg m^{-3}).

The migration of a radionuclide from a catchment may be calculated by means of the so-called Transfer Functions (TF). TF is defined as the amount of pollutant flowing per unit time from an upstream drainage basin to a water body following a single pulse deposition of a radioactive substance. Dissolved radionuclide TFs were evaluated using contamination data collected, after the Chernobyl accident, by European laboratories in some rivers in Europe (Kaniviets V.V., Voitcekhovich O.V, 1992; Mundschenk, 1992; Maringer, 1994).

The TF, which is a function of time and of water flow, may be approximated by the sum of some time-dependent exponential components (Monte, 1995)

$$\Phi_r(t) = \varepsilon D \sum_i \Phi^{\alpha_i}(t) \beta_i A_i e^{-(\lambda_r + \lambda_i)t} \quad (7)$$

$$\sum_i A_i = 1 \quad (8)$$

$\Phi(t)$ is the water flux from the catchment at time t , A_i are the relative weights of the exponential components, λ_r is the radioactive decay constant, $\lambda_i + \lambda_r$ is the effective decay constant of component i , D is the deposition onto the catchment, ε is the transfer coefficient from the catchment (i.e., the ratio of the initial radionuclide concentration in water divided by the deposition) and exponents α_i give reason for possible non-linearity of TF as a function of the water flux.

Function (7) was used to fit data of radionuclide flows in rivers. The results of the fit are reported in tables 11 and 12. The quantitative analysis of radionuclide migration fluxes is of importance for the development of radionuclide migration models.

TABLE 12. Evaluations of the parameters in the Transfer Functions of dissolved radionuclides in some European rivers

River	Radio-nuclide	ε (m^{-1}) (order of magnitude)	A_2 (dimensionless)	α_2 (dimensionless)	$\lambda_1 + \lambda_r$ (s^{-1})	$\lambda_2 + \lambda_r$ (s^{-1})	Standard deviation of $\lambda_2 + \lambda_r$	Reference
Po	^{137}Cs	$10^{-3} - 10^{-2}$			2.3×10^{-7}			Monte (1995) ^(b)
Rhine	^{137}Cs	$10^{-2} - 10^{-1}$	0.052	0.53	6.5×10^{-7}	2.7×10^{-8}	0.6×10^{-8}	Monte (1995) ^(c)
Prypiat	^{137}Cs	$10^{-2} - 10^{-1}$	0.035	1.08	5.2×10^{-7}	1.8×10^{-8}	0.7×10^{-9}	
Dniepr	^{137}Cs	$10^{-2} - 10^{-1}$	0.028	0.86	8.8×10^{-7}	1.1×10^{-8}	0.7×10^{-9}	
Teterev	^{137}Cs			0.96		8.2×10^{-9}	$2. \times 10^{-9}$	
Uzh	^{137}Cs			1.02		1.5×10^{-8}	1.8×10^{-9}	
Danube	^{137}Cs			0.74		1.8×10^{-8}	$2. \times 10^{-9}$	Monte (1997) ^(d)
Inlets of Devoke water ^(a)	^{137}Cs			1.0-1.3		1.2×10^{-8}		Hilton et al. (1993)
Inlets of lakes	$^{137}Cs^{(a)}$				$.6 \times 10^{-7}$ -	$7. \times 10^{-9}$ -		Sundblad et al. (1991)
Hillesjön and Salgsjön					1.5×10^{-7} (range)	$2. \times 10^{-8}$ (range)		
Po	^{131}I				1.1×10^{-6}			Monte (1995) ^(b)
Po	^{103}Ru				4.7×10^{-7}			
Prypiat	^{90}Sr		0.048	1.41	9.0×10^{-7}	4.9×10^{-9}	0.9×10^{-9}	Monte (1995)
Dniepr	^{90}Sr		0.166	1.4	5.2×10^{-7}	5.5×10^{-9}	0.9×10^{-9}	
Teterev	^{90}Sr			1.12		3.6×10^{-9}	2.1×10^{-9}	
Uzh	^{90}Sr			1.31		5.9×10^{-9}	1.8×10^{-9}	

(a) total ^{137}Cs (particulate+dissolved)

(b) primary data used for fitting from Queirazza & Martinotti (1987)

(c) primary data from Kaniviets, V.V. & Voitcekhovich (1992)

(d) primary data from Maringer (1994)

TABLE 13. Measured values of some parameters of the TF from catchments (particulate caesium) (from Monte, 1997)

River	α_2	95% up of α_2	95% down of α_2	$\lambda_2 + \lambda_r$ (s ⁻¹)	95% up of $\lambda_2 + \lambda_r$ (s ⁻¹)	95% down of $\lambda_2 + \lambda_r$ (s ⁻¹)
Danube	2.44	1.9	2.98	1.4 x10 ⁻⁸	2.2 x10 ⁻⁸	6.7 x10 ⁻⁹
Uzh	1.02	0.65	1.39	1.1 x10 ⁻⁸	1.8 x10 ⁻⁸	4.0 x10 ⁻⁹
Teterev	1.34	0.97	1.77	1.2 x10 ⁻⁸	1.8 x10 ⁻⁸	6.0 x10 ⁻⁹
Prypiat	1.52	1.34	1.7	1.4 x10 ⁻⁸	1.6 x10 ⁻⁸	1.3 x10 ⁻⁸
Dniepr	1.24	1.	1.37	1.2 x10 ⁻⁸	1.4 x10 ⁻⁸	1.1 x10 ⁻⁸
Desna	1.11	0.83	1.39	8.9 x10 ⁻⁹	1.3 x10 ⁻⁸	4.7 x10 ⁻⁹
Rhine	1.12	0.27	1.97	1.7 x10 ⁻⁸	2.4 x10 ⁻⁸	1.0 x10 ⁻⁸
Geometric mean	1.34			1.2 x10 ⁻⁸		

Two exponential components were detected by fitting available experimental data collected over a period of approximately 5–6 years after the Chernobyl accident. A review of values of the parameters of the TF is reported in previous papers (Monte, 1996b). The short effective decay component ($\lambda_r + \lambda_1$) ranges from 0.6×10^{-7} to $9.0 \times 10^{-7} \text{ s}^{-1}$ (dissolved ¹³⁷Cs, ⁹⁰Sr and ¹⁰³Ru), the long effective decay component ranges from 7×10^{-9} to $2.7 \times 10^{-8} \text{ s}^{-1}$ (¹³⁷Cs) and from 3.6×10^{-9} to $5.9 \times 10^{-9} \text{ s}^{-1}$ (⁹⁰Sr). The effective decay constants, despite the tremendous differences in the geological, geographical, morphological and hydrological characteristics of the examined catchments, show low variability in agreement with the conclusions of the previous discussion. The exponents α_2 for ⁹⁰Sr and for particulate ¹³⁷Cs are significantly higher than 1. Therefore, the concentrations of these radionuclides in water increase with the water flow. It is possible to conclude that, generally, high levels of water flow in the drainage basin increase the efficiency of removal of both ⁹⁰Sr and particulate ¹³⁷Cs from the basin itself. On the contrary, the exponent α_2 for dissolved ¹³⁷Cs ranges from 0.53 to 1.08 suggesting that the concentration of ¹³⁷Cs in water in such a chemical form is slightly dependent on the of water flow.

The assessment of ϵ , that is the ratio of the initial radionuclide concentration in water divided by the deposition, is more difficult. The analysis of the available data suggests that ϵ ranges from 10^{-2} to 10^{-1} m^{-1} for ¹³⁷Cs. Hilton et al., 1993 have related the initial concentration of radiocaesium to the amount of fibrous peat in the catchment.

Data of ⁹⁰Sr from eleven rivers in Italy were used to assess ϵ for this radionuclide. The average value of ϵ was estimated 0.2 m^{-1} (Monte, 1997).

Migration from water to bottom sediments

Radionuclide migration to sediment is controlled by two main processes: transport of radionuclides by sedimentation of suspended matter and direct interaction of dissolved radionuclides with bottom sediments. Generally radionuclide sedimentation, which is a predominant process controlling the removal of radionuclide from the water column, has been the object of many extensive studies in the past decades. On the contrary, the quantitative assessment of the direct interaction processes of radionuclides with bottom sediments has been the object of comparatively few studies although some researchers (Santschi et al., 1986,

Santschi et al., 1990) have enlightened the role of such a process. This kind of assessment is particularly difficult as the direct radionuclide interaction with the bottom sediment is, generally, strongly perturbed by the radionuclide sedimentation processes. The analysis of radionuclide behaviour in deep lakes with small catchments and low concentrations of suspended matter in water offered the opportunity of such an assessment. Indeed, in these lakes, the sedimentation rates are very low and do not significantly perturb the processes of direct interaction of dissolved radionuclide with bottom sediment (see Appendix: Italian contribution).

The net radionuclide sedimentation is the net transport to bottom sediment of radionuclide attached to suspended matter in water bodies as results of sedimentation and resuspension processes.

If the dissolved and the particulate radionuclide phases are in equilibrium, the radionuclide sedimentation flux ($\text{Bq m}^{-2} \text{ s}^{-1}$) is:

$$F = R_s k_d C \quad (9)$$

where R_s is the sedimentation rate ($\text{kg m}^{-2} \text{ s}^{-1}$), k_d is the partition coefficient ($\text{m}^3 \text{ kg}^{-1}$) and C is the radionuclide concentration in water (dissolved form). The sedimentation process is of importance for radionuclides like ^{137}Cs , that are characterized by high k_d values (partition coefficient).

The radionuclide sedimentation is a complex process depending on a great deal of factors. It is influenced by all the factors that affect the sedimentation rates such as the velocity and turbulence of water. Moreover, it depends on the processes of interaction of radionuclide with suspended matter that vary according to the chemical and physical characteristics of the aquatic environment and of the suspended matter. Radionuclide sedimentation shows different importance in different kinds of water bodies. For instance, sedimentation in reservoirs is dominant whereas in some points of a river erosion can be larger than sediment deposition.

In the Austrian study, lake bottom sediments were investigated with a core sampler which yielded sediment cores up to 50 cm long. Due to the long residence time of the water in the lake, the ^{137}Cs deposited in the sediments can be interpreted as essentially the total *particulate* input of ^{137}Cs into the lake; the dissolved fraction of ^{137}Cs is not covered by this method. This lake sediment investigation is considered very reliable for the assessment of the particulate transport of ^{137}Cs , since undisturbed sediment cores conserve the "erosion history" of a longer time period rather than being point samples like the water samples, which can be used to quantify the sediment-bound fraction of ^{137}Cs of lake water.

The sediment cores (example see Fig. 6) show significant ^{137}Cs maxima in a depth of 2 to 9 cm, depending of the sedimentation rate, which varies over the lake according to the path of the inflowing water. A second, but less significant maximum can be found 10–25 cm deep. Whereas the first maximum can be attributed to the Chernobyl input, the second one is due to the main ^{137}Cs influx of atmospheric nuclear bomb testing fallout around 1964. From the depth of the peak and the known time which has passed since the deposition, and neglecting the mobility of Cs in the sediment, a sedimentation velocity of 0.2–0.8 cm/a can be calculated. For the mean annual ^{137}Cs input at sampling time (1997), calculated from the the activity concentration on the upper surface of the cores, we found 197 Bq/m².a (ref. 1 May 1986). Considering the area of lake Traunsee, we get an annual input of 4.9 GBq and, relating this result to the 35 TBq ^{137}Cs inventory, an erosion rate of 140 ppm per year. Input values for this estimate are given in the following tables (see Tab. 13 – 14).

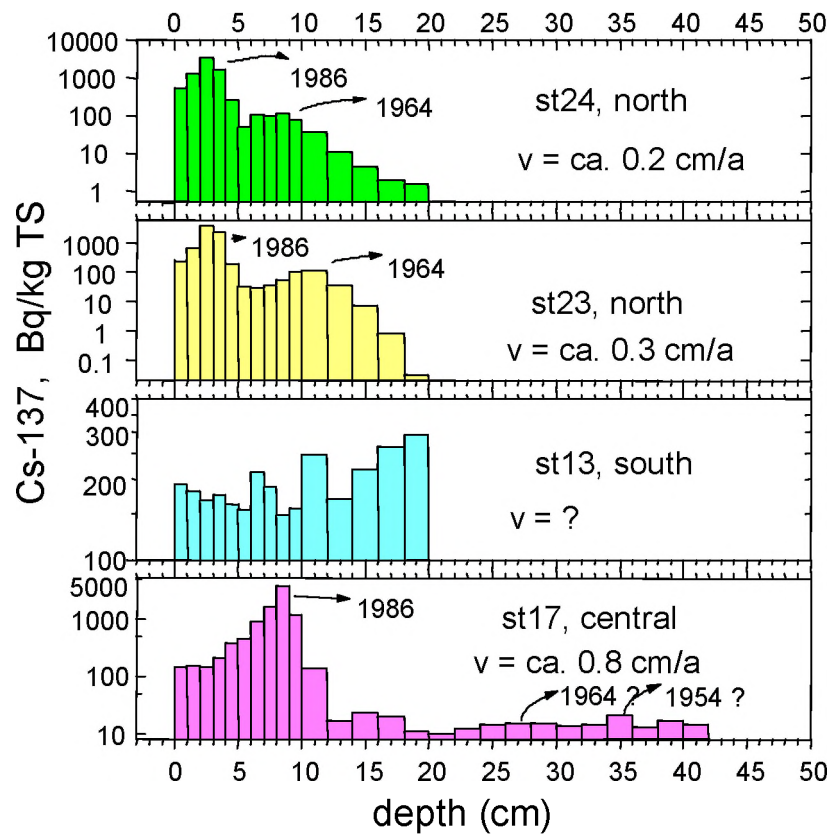

FIGURE 5. ^{137}Cs -contamination in different layers of sediment cores (1997) from Lake Traunsee, (Austria).

By fitting Gauss functions to the empirical values, the depth of ^{137}Cs maxima (x_m ; i.e. the depth, at which maximum concentration is found; σ : standard deviation) and sedimentation rates were derived from sediment core results.

TABLE 13. ^{137}Cs peak fitting results for two bottom sediment cores of Lake Traunsee (Gauss fitting results; $v_s = x_m /$ estimated peak age; x_m : half-depth; σ : standard deviation; v_s : sedimentation rate)

	^{137}Cs -Chernobyl	^{137}Cs -Bomb	^{137}Cs -Chernobyl	^{137}Cs -Bomb
	st23		st24	
x_m	2.80 cm	10.43 cm	2.58 cm	7.85 cm
σ	0.65 cm	1.71 cm	0.78 cm	2.00 cm
v_s	0.25 cm/a	0.31 cm/a	0.23 cm/a	0.23 cm/a

On basis of these results an average amount of radioactivity transfer from the catchment to lake sediments can be derived. Results are given in Tab. 14: the geometric mean of annual activity transferred to deep lake sediments is 154 Bq/m² (reference date = sampling date 1997). The following formula was used to calculate the radionuclide flux to the sediment:

$$D_1 [\text{Bq/m}^2/\text{a}] = 10 C_1 [\text{Bq/kg d.m.}] m [\text{g d.m.}] v_s [\text{cm/a}] / F [\text{cm}^2] d [\text{cm}] \quad (10)$$

C_1 = surface activity concentration, m = sample mass, F = core cross section = 58.1 cm², d = sediment layer thickness = 1 cm, v_s = sedimentation velocity; d.m.: dry matter

TABLE 14. Calculation of ¹³⁷Cs deposition rate (reference date: 1st Jan. 1997) by sedimentation in Lake Traunsee (Austria)

	C_1 (Bq/kg dry matter)	m (g dry matter)	v_s (cm/a)	D_1 (Bq/m ² /a)
st17	142.49	16.1	0.754	298
st23	~ 90	22.2	0.249	86
st24	~ 200	18.2	0.228	143
Geometric mean	137			154

From river Traun (Austria) several samples of river sediment were collected and analysed granulometrically, to find out, which grain size fraction is most important for ¹³⁷Cs transfer from catchment to river sediments (see fig. 7).

The fraction of 200–400 μm turned out to be most important, in almost all samples (12 out of 16) this fraction contained between 25 and 70% of the total activity. Coarse sediment fractions are a major mass constituent of the sediment samples, but ¹³⁷Cs concentration is comparatively low. On contrary maximum ¹³⁷Cs concentrations of each sample were measured in the clay fraction of sediments (between 200 and 8000 Bq/kg dry matter), but this fraction represents only marginal amounts (less than 1 %) of the bulk sample mass.

Thus, in spite of different approaches and conditions in the experimental sites and investigated territories, the data presented by the participants on the rates of radionuclide transport by surface waters are comparable, and the differences in the migration rates are explainable in the frame of current concept of radionuclide migration. A more detailed discussion on radionuclide transport by surface water is presented in the “Modeling” chapter.

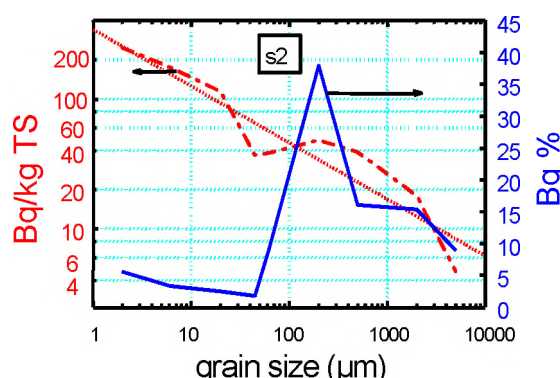

FIGURE 6. ¹³⁷Cs (concentration and total) in river sediment samples: dependence of sediment grain size distribution.

Seasonal variability of ^{137}Cs concentration in surface waters

Seasonal conditions strongly influence the behaviour of radionuclides in water bodies. A well known example is the influence of the thermal stratification of water on the distribution of radionuclides in lakes. For instance, deep lakes in the Mediterranean area show stratified structures from around the second half of spring to autumn. During the stratification period the presence of a gradient of temperature prevents the vertical diffusion of dissolved substances through the water column. Indeed, the eddy diffusion coefficient from the epilimnion (the upper layer of lake water showing a homogeneous temperature profile) to the deeper layers of water is, during the stratification period, orders of magnitude greater than during the period of water mixing. The dependence of radionuclide distribution in the water column on such a phenomenon was also observed in lakes contaminated following the Chernobyl accident (Monte et al., 1991).

Obviously the seasonal variation of water run-off fluxes is an important process that influences the radionuclide migration from catchments. Many experimental evidences have demonstrated that the concentration of ^{90}Sr , a radionuclide characterised by low k_d values, in river is related to the water fluxes. Such a phenomenon is reflected in the values of parameter α in TF. As previously noticed, these values are greater than 1 showing that the concentration of ^{90}Sr in water rises with the water flux. As the concentrations of particulate matter in rivers may depend on the seasonal behaviour of the water fluxes, the concentrations of the particulate form of radionuclides characterised by high values of k_d , such as ^{137}Cs , may vary according to seasonal conditions.

The loss of caesium from catchments via surface waters can be estimated by multiplication of annual water discharge (e.g. provided as average flow rate in l/s.km^2) and radionuclide concentration in water. In order to get information on the uncertainty of such estimates, seasonal variability of ^{137}Cs concentration in surface water samples was assessed in Austria and Lithuania.

Repeated sampling of several small rivulets in Austria revealed a considerable seasonal variability of ^{137}Cs concentration (see Fig. 8). Relative standard deviation (% of mean value; $n = 7$ to 11 sampling dates) amounted to between 18 and 131% of mean values for the investigated five waterflows and 2 ponds. The partitioning of activity between solid and liquid phase showed much less seasonal variability (between 11 and 36% of mean value).

Therefore, a high uncertainty of estimates has to be taken into account, if radiocaesium losses from small catchments via surface water are calculated on single time measurements.

Radionuclide migration to deep ground water and aquifers

Soil and vegetation covers in general serve as an effective “filter” preventing radionuclides from significant migration to deep ground water. Radionuclide migration to deep ground water and aquifers of various depth and time of formation were studied by Ukrainian participants.

After the Chernobyl accident groundwater radionuclide contamination of main aquifers at the area of Kiev Industrial and Urban Agglomeration (KIUA) was assessed. Measurable amounts of ^{137}Cs and ^{90}Sr had been determined in relatively great depth. In the first sampling campaign more than 20 wells had been identified, where water samples contained trace amounts of short living ^{134}Cs [Goudzenko, 1997].

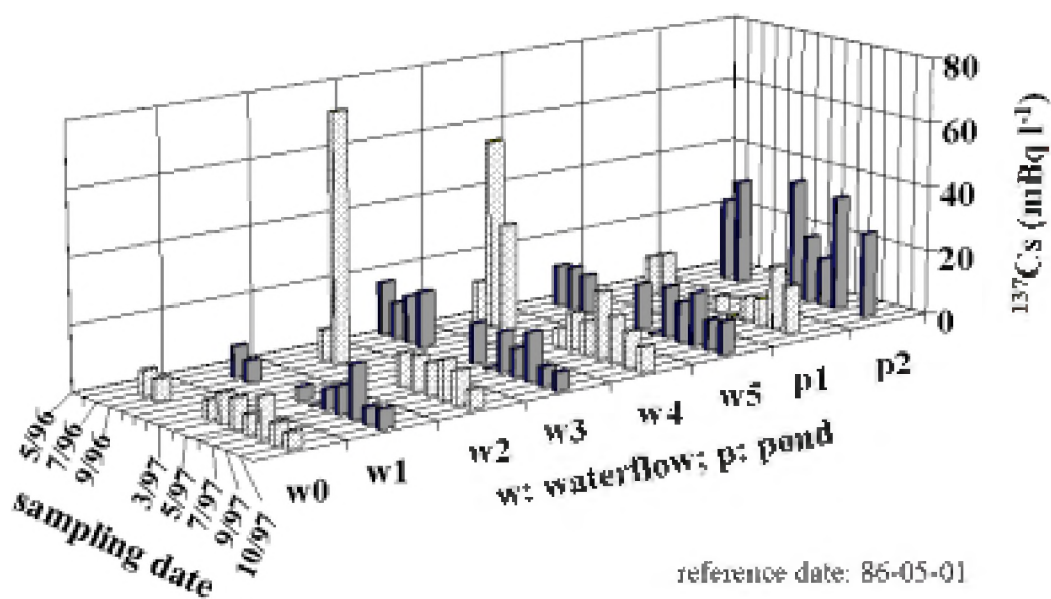

FIGURE 7. Seasonal variability of ^{137}Cs concentration in surface water samples (May 1996–October 1997) of different small waterflows from a forested catchment (Weinsberger Forest, Austria).

TABLE 15. Concentrations of artificial radionuclides in the groundwater of Kiev (KIUA, mBq/l)

Aquifer	Number of measurements	Minimal value		Maximal value		Arithmetic mean	
		^{137}Cs	^{90}Sr	^{137}Cs	^{90}Sr	^{137}Cs	^{90}Sr
P ₂ bc	35	0.80	0.70	21.90	17.43	5.26	3.32
K ₂ cm	73	0.50	0.10	17.32	7.12	4.37	2.55
J ₂ bj	68	0.70	0.40	7.10	6.60	3.96	3.46

Further observations confirmed the previous results that ^{137}Cs and ^{90}Sr was present in the wells of the municipal water supply system in the city of Kiev and her suburbs. (Table 15)

Maximal concentrations of ^{137}Cs for the upper aquifer, located in the Quaternary deposits, reach up to 50 mBq/l in 1992. The maximum for ^{90}Sr was about 20 mBq/l. For deeper aquifers such as Neogene, Palaeogene, Cretaceous and Jurassic maximal concentrations in the groundwater were smaller, approximately 20 and 10 mBq/l respectively. Concentration of ^3H in these water bearing sets reach up to several Bq/l. Such deep and quick penetration of radionuclides from the surface to the groundwater compels to search for suitable, preferential pathways and mechanisms of their movement.

Despite concentrations of fission products in the groundwater of KIUA today are well below the permissible levels, the investigation of this phenomenon seems to be very important. A lot of possible contaminants, generating in IUAs, may move through the unsaturated zone by the same mechanisms as radionuclides.

Measurable amounts of ^{137}Cs and ^{90}Sr have been determined sometimes in the soils and rocks of Kiev down to a depth of 300 m. In some cases, maximum radionuclide concentration in Kiev springs was extremely high (up to 0.69 Bq/l).

The Chernobyl origin of these nuclides, as mentioned above, was confirmed during the first stage of this investigation. Simultaneously with the monitoring of ^{137}Cs and ^{90}Sr in well-water of the municipal water supply system, a set of marl samples had been collected from newly built metro tunnels, water, sediments and sinters from drainage adits, built on the slopes of Dniepr valley and its little tributaries to protect slides. In general, no considerable percolation of any radionuclide has been found in the underground water sources supplying the town of Kiev.

TABLE 16. Concentrations of ^{90}Sr in the waters of Kiev-city (mBq/l)

Type of source	Number of measurements	Minimal value	Maximal value	Arithmetic mean
Wells K ₂ cm	28	0.40	4.70	1.78
Wells J ₂ bj	24	0.40	6.90	3.22
Springs	4	13	688	286
Drainage adits	8	0.50	8.90	5.7
Wells K ₂ cm	28	2.40	21.10	6.39
Wells J ₂ bj	24	2.20	11.80	6.82

Some other data presented by the Ukrainian participants suggests that there may be fast pathways from surface water to the groundwater aquifers (Fig. 9). Although the radionuclide concentration found in the groundwater was not above safe drinking water levels, the fast response of caesium and strontium concentration in these aquifers to the atmospheric precipitation input may need to be studied in more detail to understand the effects of well-construction on radionuclide migration.

Transport of natural radionuclides from groundwater to a coastal lagoon

In the Brazilian study the transport of radionuclides of natural radioactive series and light rare earth elements into a coastal lagoon system, located in a monazite rich region, was assessed. The water analysis showed the decrease of radium (Ra-228 from 1.6 to 0.1 Bq/L; Ra-226 from 0.4 to 0.1 Bq/L) and LREE concentrations (La from 26 to 0.14 $\mu\text{g/L}$, Ce from 54 to 0.29 $\mu\text{g/L}$, Pr from 7.18 to 0.08 $\mu\text{g/L}$, Nd from 29 to 0.15 $\mu\text{g/L}$ and Sm from 4.56 to 0.08 $\mu\text{g/L}$) in the seaward direction. On the other hand, variables as pH (from 4 to 8) and major ion concentrations (salinity from 9‰ to 42 ‰, Cl from 487 to 2300 mg/L, Na from 401 to 1500 mg/L, K from 13 to 67 mg/L, Ca from 7.5 to 112 mg/L, sulfate from 26 to 130 mg/L) showed increased concentrations in the same direction. The average concentration of dissolved organic carbon was 11 mg/L in all station waters.

By analyzing the gradient of the radium concentration the unknown source of radium could be identified: insurgent groundwater at the less brackish zone of the lagoon. The insurgent water contained ca. 3.5 Bq/l Ra-228 and 0.7 Bq/l of Ra-226, pH was about 3.7.

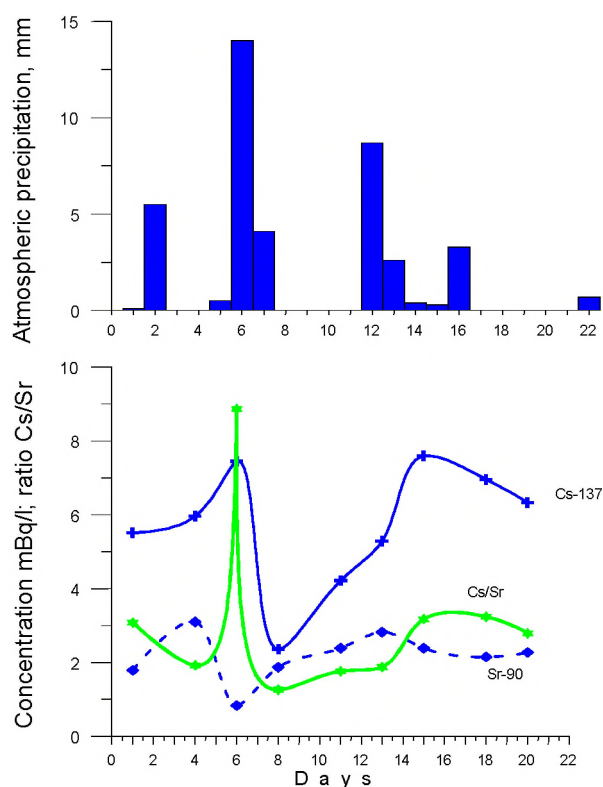

FIGURE 8. Short term monitoring of radionuclide concentrations in the water of exploitation well No. 360 (K2cm, Kiev city) versus atmospheric precipitation.

Factor extraction from principal component analysis of the variables pointed out three factors as responsible for approximately 82% of the water's data variance: the factor 1 (Ce, La, Nd, Pr and radium isotopes) explained 39%, factor 2 (Na, Cl, K, sulfate, Ca, Mg) 32% and factor 3 (Fe, Mn e U) explained 11%. Thus, the composition of the water of the lagoon can be mainly attributable to Monazite's dissolution (factor 1) and to the seawater (factor 2). The uranium concentration can be attributable to two different sources: seawater and Monazite's dissolution.

Through the Ra-228/Ra-226 concentration ratios, a period of circa 6 years was estimated for radium to go through 1900 meters, this is equivalent to an estimated effective migration velocity of 300 m/year.

CONCLUSIONS

Research conducted within the CRP confirms that mobility of radionuclides through the surface and the ground water systems is dependent on the physical and chemical properties of the contaminant, and on the rock and sediment characteristics. Radionuclides such as ⁹⁰Sr that commonly occur in the aqueous phase were found to be very mobile within the aquatic environment. Other radionuclides such as ¹³⁷Cs that strongly interact with the particulate matter suspended in water, with the bottom sediments, and with solid particles show comparatively lower levels of mobility.

The experimental evidence that was gathered also demonstrates that the horizontal migration of radionuclides through surface waters is of paramount importance. Horizontal radionuclide fluxes in surface water are generally high, and often determine the spatial extent of

contamination. In general, vertical migration of radionuclides to the underlying groundwater aquifers is comparatively lower. In fact, soils were found to be effective filters for radionuclide transport to underground water. For example, studies carried out in Belarus and Russia show that the radiocesium and radiostrontium of Chernobyl fallout are still retained by the upper layers of the soil humus horizon, fourteen years after the accident.

The vertical migration characteristics were found to depend mostly on the contaminant levels and their form (hot particles or aerosols), on the radionuclide in question, on the soil and rock characteristics, and on the hydrological properties of the aquifer. The experimental studies carried out in the framework of the CRP have also demonstrated that the highest ^{137}Cs at a depth of few decimetres do not exceed 0.005% of the total deposition. Lower infiltration rate is expected for Pu (0.001%), while ^{90}Sr may show infiltration rates one order of magnitude higher than ^{137}Cs . In hydromorphic soils with a well-developed peat layer, the annual infiltration rates of ^{137}Cs at the depth of 0.5m may reach 0.01 of the total deposition.

Vegetation cover and soil microbiota may have a strong seasonal and long term effect on radionuclide (primarily ^{137}Cs) mobility and vertical migration through the soil. Field data suggest that up to 40% of the total deposition in hydromorphic forest environments may be immobilized in the living biomass (tree vegetation, fungi, mycelium, etc). In automorphic landscapes, the corresponding value is only 13–15%.

A study of vertical migration of Chernobyl radionuclides near Kiev demonstrates a lack of significant fluxes of radionuclides to deep aquifers. However, fast migration of ^{137}Cs to pumping wells may occur preferential pathways associated with well construction and other human activities.

The above considerations are applicable to radionuclides showing relatively high soil-water partition coefficients such as Cs and Pu isotopes. Other radionuclides, characterized by very low soil-water partition coefficients, can show comparatively higher levels of vertical migration.

Naturally occurring radionuclides can also provide valuable insight into pollutant migration mechanisms in the aquatic environment. The study of the distribution of radium isotopes in the water column of a coastal lagoon in Brazil has shown that factors such as hydrological regime (salinity, pH, etc) can greatly influence the migration processes.

Few previous studies have evaluated the direct diffusion of radionuclides from water to sediment, although this process was found to be significant in lakes with negligible sedimentation rates in the present study. “Migration velocity” due to the direct diffusion of ^{137}Cs from the water to lake sediments was estimated at 2.4×10^{-8} to $1.1 \times 10^{-7} \text{ m s}^{-1}$.

The analysis of radionuclide concentrations in river waters contaminated following the Chernobyl accident and from prior nuclear weapon tests in the atmosphere has provided a unique opportunity for assessing the behaviour of radionuclide migration from catchments. The time behaviour of a contaminant flux, following a single pulse deposition of radionuclide, may be described by means of a so-called Transfer Function (TF). The assessment of the TF offers the opportunity of developing simple and reliable models for predicting the radionuclide migration from catchments. In homogeneous systems it was found that the dominant landscape type can have a considerable influence on the transfer of radionuclides from the catchment to the hydrosphere. In small, forest-dominated catchments containing

bogs, ^{137}Cs outflow via surface waters was found to be higher than for similar, agriculturally-dominated catchments. Moreover, the partitioning of ^{137}Cs between the dissolved phase and particulate (suspended) matter phase was different in various surface waters. Overall, higher fluxes of dissolved ^{137}Cs were observed in semi-natural water-flows, attributed to presence of a continuous vegetation cover preventing soil erosion during surface runoff.

New conceptual approaches for modelling the behaviour and the transport of radionuclides through freshwater systems were reviewed within the CRP. It is obvious that the migration of radionuclides from a catchment is a very complex process that depends on the hydrological and geological characteristics of the constituent parts (sub-catchments) of the drainage area. Radionuclide migration from a large catchment often tends to reflect an integrated average response based on the “ensemble” of physiographic, climatic and land use types that it comprises. “Statistical aggregation” of processes is one approach that may be further developed to model radionuclide migration in large, complex systems. A review of collective models, which are simple and require only a small number of site-specific parameters, suggests that these models may also be useful and adaptable tools for radiation protection and management of freshwater resources.

REFERENCES

- [1] ABRAHAM, J.P., F.W. WHICKER, T.G. HINTON, D.J. ROWAN (2000): Inventory and spatial pattern of ^{137}Cs in a pond: a comparison of two survey methods. *Journal of Environmental Radioactivity*, 51(2): 157–171.
- [2] AGAPKINA G.I, KRACK W., et al., Association of Chernobyl-derived (1995) $^{239+240}\text{Pu}$, Am, ^{90}Sr , and ^{137}Cs with organic matter in the soil solution. *J. Environ. Radioactivity*, vol. 29, no. 3, pp. 257–269.
- [3] ALEXAKHIN, R.M. and NARYSHKIN M.A., *Migratsiya radionuklidov v lesnykh biogeotsenozakh* (Radionuclide Migration in Forest Biogeocenoses), Moscow: Nauka, 1977.
- [4] Appelgren, A., Bergstrom, U., Brittain, J., Gallego, E., Hakanson, L., Heling, R., Monte, L. (1996). An outline of a model-based expert system to identify optimal remedial strategies for restoring contaminated aquatic ecosystems: the project MOIRA. ENEA Technical Report, RT/AMB/)&, Rome, Italy.
- [5] BARBER, S.A. Biological availability of soil nutrients in the soil, Moscow, 1988.
- [6] BIOMOVs (1990). On the validity of environmental transfer models. Proceedings of a Symposium, October 8–10, 1990. Stockholm, Sweden. Swedish Radiation Protection Institute.
- [7] BIOMOVs (1991). Scenario A5: Dynamics within lake ecosystems. Technical Report 12. Björn Sundblad (ed). National Institute of Radiation Protection, Sweden.
- [8] BIOMOVs II (1996). Model validation studies of water flow and radionuclide transport in vegetated soils using lysimeter data. BIOMOVs II Technical report No. 15, Swedish Radiation Protection Institute 17116 Stockholm, Sweden.
- [9] BOLYUKH, V.A., Vertical Distribution of ^{137}Cs in Forest Ecosystems of Kiev Poles'e, *The 5th Conference "Liquidation of the Chernobyl Accident Consequences: the Results of 10-year Work"*, Zelenyi Mys, 1996, p. 262.
- [10] BURROUGH, P.A., M. Van der Perk, B.J. Howard, B.S. Prister, U. Sansone, O.V. Voitsekohovitch (1999): Environmental mobility of radiocaesium in the Pripjat catchment, Ukraine&Belarus. *Water, Air, & Soil Pollution* 110(1–2): 35–55.
- [11] DAILY, J., W. & HARLEMAN, D. R. F. *Fluid Dynamics* (1973) .Addison-wesley Publishing Company, Inc. Reading, Massachusetts, USA. pp. 454.

- [12] FILEP D., REDLY O., VARRO, T. Transport of clays in the soils of different porosity and moisture. *Pochvovedenie (Soil Science)*, 1986. no. 10. pp. 55–62.
- [13] GOUDZENKO, V. (1997) Artificial radionuclides as a tool for groundwater contamination assessment: Experience following the Chernobyl disaster. In *Groundwater in the Urban Environment. Vol.1, Problems, Processes and Environment*, Balkema, Rotterdam, 1997 p.141–144.
- [14] HAKANSON, L. (1995). Optimal size of predictive models. *Ecological Modelling*, 78 : 195–204.
- [15] HAKANSON, L. (1999): A compilation of empirical data and variations in data concerning radiocesium in water, sediments and fish in European lakes after Chernobyl. *Journal of Environmental Radioactivity*, 44(1): 21–42.
- [16] HAKANSON, L., J.E. BRITTAIN, L. MONTE, R. HELING, U. BERGSTROM, V. SUOLANEN (1996): Modelling of Radiocesium in Lakes - the VAMP Model, *Journal of Environmental Radioactivity*, 33(3): 255–308.
- [17] HILTON, J. LIVENS, F.R., SPEZZANO, P., LEONARD, D.R.P. (1993) Retention of radioactive caesium by different soils in the catchment of a small lake? *The Science of the Total Environment* 129: 253–266; 1993.
- [18] IAEA (2000). Modelling of the transfer of radiocaesium from deposition to lake ecosystems Report of the VAMP Aquatic Working Group. IAEA-TECDOC-1143 (Edited by: K.-L. Sjoebloom).
- [19] JORGENSEN S.E. (1983). The modelling procedure. In: application of Ecological Modelling in environmental management. Part A. Jorgensen (Ed.) Elsevier Scientific Publisher Company. Amsterdam : 5–15.
- [20] JOSHI S. R., SHUKLA, B. S. (1991): The role of water / soil distribution coefficient in the watershed transport of environmental radionuclides. *Earth Planetary Sci. Lett.*, 105:314–318, 1991.
- [21] KANIVIETS, V.V. & VOITCEKHOVICH O.V. 1992- Scientific report: Radioecology of water systems in zone of consequences of Chernobyl accident. Report of Ministry of Chernobyl Affairs of Ukraine. Contract Number 1/92: pp.270. (In Russian).
- [22] Kersting, A.B., D.W. Efurud, D.L. Finnegan, D.J. Rokop, D.K. Smith, and J.L. Thompson (1999): Migration of plutonium in groundwater at the Nevada Test Site. *Nature* 397(7): 56–59.
- [23] KLYASHTORIN, A.L., TIKHOMIROV, F.A. & SHCHEGLOV A.I. Lysimetrical study of radionuclides in the forests around the Chernobyl Nuclear Power Plant. *Journal of Environmental Radioactivity*, 1994, 24, 89–90.
- [24] KIRCHNER G.(1998a): Applicability of compartmental models for simulating the transport of radionuclides in soil. *Journal of Environmental Radioactivity*, 38, 339–352.
- [25] KIRCHNER, G. (1998b): Modeling the migration of fallout radionuclides in soil using a transfer function model. *Health Physics*, 74, 78–85.
- [26] KIRCHNER, T. B. (1990) Establishing model credibility involves more than validation. In.: On the validity of environmental transfer models. Proceedings of a Symposium, October 8–10, 1990. Stockholm, Sweden. Swedish Radiation Protection Institute. 371–378.
- [27] KOMOSA, A. (2001). Study on geochemical association of plutonium in soil using sequential extraction procedure. *J. Radioanal. Nucl. Chem.* (to be published).
- [28] LOSHCHILOV, N.A., Ivanov, Yu.A., Kashparov, V.A., Levchuk, S.E., Bondar, P.F., Dyrenko, L.V. Vertical migration of different physico-chemical forms of Chernobyl-born radionuclides in the soils of Poles'e region. *Problems of Agricultural Radiology*, Kiev, 1991, pp. 36–44.
- [29] MALMGREN, L., and M. Jansson (1995): The fate of Chernobyl radiocesium in the River Oere catchment, northern Sweden. *Aquatic Sciences* 57(2): 144–160.

- [30] MARINGER F.J. Das Verhalten von Radionukliden im Wasser, Schwebstoff und Sediment der Donau. Dissertation, Technischen Universität Wien, April 1994.
- [31] MATSUNAGA, T., T. UENO, H. AMANO, Y. TKATCHENKO, A. KOVALYOV, M. WATANABE, Y. ONUMA (1999): Characteristics of Chernobyl derived radionuclides in particulate form in surface waters in the exclusion zone around the Chernobyl Nuclear Power Plant. *Journal of Contaminant Hydrology*, 35(1-3): 101-113.
- [32] MONTE, L., FRATARCANGELI, S. QUAGGIA, S. POMPEI, F. & ANDRASI, G. (1991) A predictive model for the behaviour of dissolved radioactive substances in stratified lakes. *Journal of Environmental radioactivity* 13: 279-308.
- [33] MONTE, L. (1995) Evaluation of radionuclide transfer functions from drainage basins of fresh water systems. *J. Environ. Radioact.* 26: 71-82.
- [34] MONTE L., (1996a). Collective models in environmental sciences. *The Science of the Total Environment* , 192:41-47.
- [35] MONTE, L. (1996b) Analysis of models assessing the radionuclide migration from catchments to water bodies. *Health Physics*, 70:227-237.
- [36] MONTE, L. (1997) A collective model for predicting the long term behaviour of radionuclides in rivers. *The science of the Total environment*, 201: 17-29.
- [37] MONTE, L. (1998): Predicting the migration of dissolved toxic substances from catchments by a collective model. *Ecological Modelling*, 110(3): 269-279.
- [38] MONTE, L. & HAKANSON, L. 1999. On New Approaches to structure Mathematical Models and Increase Predictive Power for the Transport and Biouptake of radionuclides in Aquatic Systems. In: *Mathematics and Computation, Reactor Physics and environmental Analysis in Nuclear Application. Proceeding of a Symposium*, September, 1999, Madrid Spain:1530-1543.
- [39] NIRP 1990. The Swedish radiation Protection Institute> Proceedings of the Symposium BIOMOVs on the Validity of Environmental Transfer Models, Stockholm, Sweden October 8-10, 1990.
- [40] NYLEN, T. H. GRIP (1997). The origin and dynamics of ¹³⁷Cs discharge from a coniferous forest catchment. *Journal of Hydrology*, 192(1/4): 338-354.
- [41] PATTEN, B., C., BOSSERMAN, R., W., FINN, J.,T. & CALE, W., G. (1976). Propagation of Cause in Ecosystems. In : *Systems Analysis and Simulation in Ecology*, B. C. Patten (Ed.) Vol. IV. Academic Press, Inc. Pp. 457-579.
- [42] QUEIRAZZA, G. & MARTINOTTI, W. Radioattività nell'acqua del PO: tratto mediano e delta (1987). *Acqua Aria* 7:819-830.
- [43] TYLER, A.N., K.V. Heal 2000. Predicting areas of ¹³⁷Cs loss and accumulation in upland catchments. *Water, Air and Soil Pollution*, 121 (1/4): 271-288
- [44] TIPPING, E. 1996. Hydrochemical modelling of the retention and transport of metallic radionuclides in the soils of an upland catchment. *Environmental Pollution*, 94(2): 105-116.
- [45] SANCHEZ-CABEZA, J.A., L. PUJOL, J. MERINO, J.M. BRUACH, J. MOLERO (2000): Artificial radionuclides in waters of the lower section of the river Ebro (Northeast Spain). *Water, Air, & Soil Pollution*, 118(3-4): 339-35.
- [46] SANTSCHI, P. H., NYFFELER, U. P., ANDERSON, F. R., SCHIFF, L. S., O'HARA P. & HESSLEIN R. H. (1986) Response of radioactive trace metals to acid-base titrations in controlled experimental ecosystems: evaluation of transport parameters for application to whole-lake radiotracer experiments. *Canad. J. Fish Aquat. Sci.* 43: 60-77.
- [47] SANTSCHI, P. H., BOLLHANDER, S., ZINGG, S., LÜCK, A. & FARRENKOTHEN, K. (1990) The self-cleaning capacity of surface waters after radioactive fallout. Evidence from European waters after Chernobyl, 1986-1988. *Environ. Sci. Technol.* 24: 519-527.

- [48] SHCHEGLOV A. I., TIKHOMIROV F., TSVETNOV, O.B. et. al, Biogeochemistry of Chernobyl-born radionuclides in Forest Ecosystems of European Part of CIS, *R.di..ts. biologiya, radioekologiya*, 1996. v. 36, issue 4, pp. 437–446.
- [49] SHCHEGLOV, A.I. *Biogeochemistry of Technogenic Radionuclides in Forest Ecosystems*, Moscow: Nauka, 2000, 262 pages (in Russian).
- [50] SHESTOPLOV V.M., BUBLYAS' V.P., GUDZENKO V.V. et. al. Study of the Fast Vertical Migration of Radionuclide in Geological Environments, *Chernobyl-94: The IV International Conference "The Results of 8-year Activities on Liquidation of the Chernobyl Accident Consequences."*, *Zelenyi Mys*, 1996, v. 1, pp. 110–119.
- [51] SLOAN, W.T. and J. EWEN (1999): Modelling long term contaminant migration in a catchment at fine spatial and temporal scales using the UP system. *Hydrological Processes*, 13(6): 823–846.
- [52] SMITH, J. T., CLARKE, R. T., SAXÉN, R. (2000). Time-dependent behaviour of radiocaesium: a new method to compare the mobility of weapons test and Chernobyl derived fallout. *Journal of Environmental Radioactivity* 49:65–83.
- [53] SUNDBLAD, B. BERGSTRÖM, U. SVERKER, E. (1991). Long term transfer of fallout nuclides from the terrestrial to the aquatic environment. In: Moberg, L. ed. *The Chernobyl fallout in Sweden. Results from a research program on environmental radiology*. Stockholm: The Swedish Radiation Protection Institute; 207–238; 1991.
- [54] TYLER, A.N., HEAL, K.V. (2000). Predicting areas of ¹³⁷Cs loss and accumulation in upland catchments. *Water, Air and Soil Pollution* 121 (1/4): 271–288.
- [55] WESLEY, J. P., 1974. *Ecophysics. The application of physics to ecology*. Charles Thomas Publisher: Springfield, Illinois, USA pp. 340.
- [56] ZHELEZNYAK, M., DEMCHENKO, R., KHURSIN, S., KUZMENKO, YU., TKALICH, P. & VITJUK, N. (1992) Mathematical modelling of radionuclide dispersion in the Prypiat-Dnieper aquatic system after the Chernobyl accident. *Sci. Total. Environ.* 112, 89–114.

¹³⁷CS INTERACTIONS BETWEEN SOIL CONTAMINATION AND HYDROSPHERE

F. STREBL, M.H. GERZABEK

Austrian Research Center Seibersdorf, Department of Environmental Research, Seibersdorf

K. KIENZL

Austrian Federal Environment Agency, Vienna

H. LETTNER, P. BOSSEW

University of Salzburg, Department of Biophysics, Salzburg

Austria

Abstract

In the contributed study the amount of ¹³⁷Cs loss via surface water and transported sediments from catchments of different landscape characteristics and size was quantified. At the first investigation site (small semi-natural catchment (9.2 km²) in the Northern Granite Highlands of Austria, vegetation cover: forests and meadows, partly bog sites; soil pH < 5, loamy sands rich in organic matter; ¹³⁷Cs inventory: 55.3 kBq/m²) the ¹³⁷Cs concentration in small surface water flows amounted to 6.4 ± 1.6 mBq/l in the dissolved phase and 3.5 ± 1.4 mBq/l (reference date: 1986-05-01) bound to suspended particles. Annual export rates in the observed subcatchments varied between 78–167 × 10⁻⁶ per year, seasonal variation of observed data was considerable. The second investigation site was situated in the lake district of the Austrian Alps, the River Traun catchment (1492 km², 50.8 kBq/m² ¹³⁷Cs soil contamination) agricultural land, meadows, calcareous landscape), it was divided into several subcatchments, where river water was sampled. Additionally, from some lakes (Traunsee, Hallstaedter See) sediment cores were taken to determine the ¹³⁷Cs depth distribution and the radionuclide amount stored within lake bottom sediments. ¹³⁷Cs concentration in surface waters of river Traun and its inflows was 0.41 ± 0.44 mBq/litre (dissolved phase) plus 1.28 ± 1.16 mBq/l in the suspended sediment. Derived export rates of 150 × 10⁻⁶ are comparable to the upland catchment, but the relation between sediment and dissolved transport was distinctly different. Results from Lake Traunsee sediment core analysis were used to calculate the sedimentation rate and the ¹³⁷Cs input to the lake respectively.

INTRODUCTION AND AIMS

In 1996, as a consequence of routine analyses of sewage sludge samples from different regions in Austria elevated ¹³⁷Cs levels were detected in several samples from Upper Austrian sewage treatment plants with mixed channel systems (i.e. collecting both waste water and precipitation surface runoff water). Therefore, a multidisciplinary working group was organized by the Austrian Environment Agency. The aim of the group is to investigate principal interactions between terrestrial and aquatic ecosystems and the transfer of radiocesium from soil to surface waters. At two ecologically different catchments (small upland and large alpine catchment) following research was carried out: quantification of ¹³⁷Cs output from a defined catchment areas via outstreaming surface waterflows; distribution of ¹³⁷Cs between the solid (fixed to transported sediment) and liquid (solved in water or bound by water soluble molecules) phase of surface waters; calculation of radionuclide fluxes out from the catchments.

Project partners

Austrian Federal Environment Agency (Sponsor; K. Kienzl)

Federal Institute for Food Control and Research Vienna and Linz (V. Karg, W. Ringer)

University of Salzburg / Dept. Biophysics (H. Lettner, P. Bossew)

Austrian Research Center Seibersdorf / Dept. Environmental Research (M.H.Gerzabek, F. Strebl)

Austrian Research and Testing Centre Arsenal/Dept. Hydrogeology (F.J. Maringer, A. Ramer)

Material and Methods

Weinsberger Wald: Weinsberger Forest is situated in the north of Austria, within the granite highland of Waldviertel. The area is covered by managed spruce forests and extensively used meadows. The soils are characterised by very acid pH-values, low base saturation and a high amount of organic carbon even in B-horizons. Mean ^{137}Cs -soil contamination: 55 kBq/m². Within an area of 9.5 km² five small waterflows and their respective catchments were identified according to the orographic situation deduced from map material. Besides soil sampling for the determination of total ^{137}Cs site inventory the 5 waterflows were sampled monthly (app. 20 liter) near the point, where they leave their catchment (W1 - W5) and additional water samples were taken at the point, where the main water flow leaves the investigation site (w0) and from two ponds within the area (WK, WM).

Water samples were divided into liquid phase and suspended mineral components by sedimentation of at least one month. The mean annual amount of water flowing out from the catchments was determined by several methods (salt tracer method and calculations based on precipitation data).

The second investigated catchment is located in Salzkammergut. Its main characteristics are mountains up to almost 3000 m, mainly limestone, several lakes imbedded in the river valleys and high rainfall. The largest and deepest lake is lake Traunsee, with an area of 24.4 km², a maximum depth of 189 m and a volume of 2.23 km³. Its main tributary is river Traun whose theoretical residence time in the lake is ca. 1 year. The catchment area until the point where the Traun leaves the lake is 1417 km². However, the drainage area effective for *particulate* erosion is smaller, since further lakes upstream lake Traunsee serve as efficient sediment traps, i.e. represent barriers against sediment transport from further upstream. Therefore, the effective catchment area of lake Traunsee for particulate transport is only 534 km².

The total ^{137}Cs inventory was assessed by interpolation (kriging) of in situ measurements and analysed soil samples. The lake bottom sediments (24 samples) were investigated with a core sampler, which yielded sediment cores up to 50 cm long. Water samples (60 l) from river Traun and its tributaries were collected in summer 1997 and processed as described above for separate analysis of water and suspended material. Sediment cores were cut into cm – slides and analysed granulometrically and for ^{137}Cs .

Results

Previous studies investigated the behaviour of radiocesium within forest soil and soil plant transfer. From the results it can be concluded that ^{137}Cs is plant available and migrates within the soil profile at least to some extent. A significant increase of radiocesium concentration occurs due to vertical migration in the mineral layers of forest profiles.

Results about the spatial variability of ^{137}Cs soil contamination for the five catchment areas is listed in Tab.1. Because of the different area sizes the radiocesium inventories differ widely between 17 and 159 GBq.

TABLE 1. ^{137}Cs contamination of Weinsberger Forest and its subcatchments (Ref. date: 86-05-01)

catchment	area size (km ²)	inventory ^{137}Cs (GBq)	average ^{137}Cs - deposition (kBq/m ²)
1	1.18	74	62.5
2	0.71	51	71.3
3	2.99	159	53.4
4	0.28	17	60.2
5	2.31	110	47.5
remnant	1.49	98	65.9
total	9.22	510	55.3

The results of water analyses revealed, that comparatively high amounts of cesium are leached into the waterflows. Average concentration amounts to 12 mBq/l.

The relation between cesium fixed to mineral sediment components and water-soluble cesium shows a high variability, values are higher than data found in the literature for danube river. More than 50% of cesium is present in the liquid phase of the water samples (see Fig.1). One reason could be the lack of fixing sediment, another reason could be the presence of water-soluble humic acids, which can bind cesium. The waters of this investigation area show a remarkable yellow colour. Within the forested catchment patches of sphagnum can be found locally and bog sites are frequent in this type of landscape.

In comparison with the seasonal variation of the fractionation of ^{137}Cs between suspended material and liquid phase of surface water, the variation between investigated waterflows was much smaller (see Fig. 1).

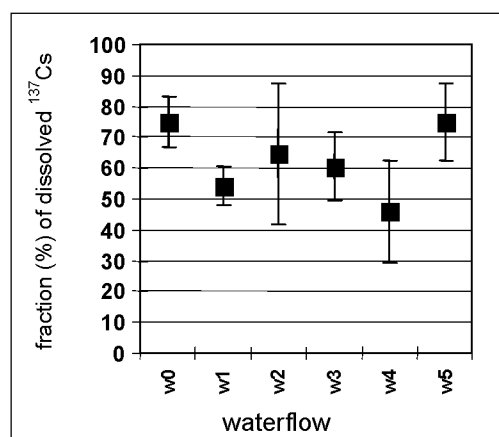

Fig. 1. Average ^{137}Cs fraction present in the liquid phase of surface waters from five small waterflows (w1-w5) and Prinzbach (w0) (arithmetic mean with standard deviation of $n = 7 - 8$).

As gross average including all sampling dates and sites 64.8 ± 5.3 % of ^{137}Cs are detected in the liquid phase of water samples. From the collected results no correlation was found between the soil contamination level and the ^{137}Cs concentration of surface waters.

Results from measurement of soil and water samples were combined to estimate the annual average loss of activity from the five catchment areas and the total investigation area (see. Tab. 2)

TABLE 2. ^{137}Cs concentration in water samples, export of activity via surface water, derived loss rates for ^{137}Cs from catchment area via surface waters (total=both liquid and solid phase; reference date: 1997-01-01)

catchment	median concentration in surface water (solid+liquid)(mBq/l)	exported activity via surface water (MBq / a)	catchment soil inventory (GBq)	^{137}Cs export rate (10^{-6} per year)
w 0	7.1	31.0	399	78
w 1	6.5	3.6	58	63
w 2	10.4	3.5	40	88
w 3	12.4	18.0	124	142
w 4	13.0	1.8	13	132
w 5	13.1	14.0	86	167

As derived from Tab. 2 the median annual loss rate of ^{137}Cs via surface waters amounts to 110×10^{-6} per year, i.e. less than 0.01% of soil inventory is lost due to surface water outflow from the catchment.

The sediment cores from Lake Traunsee show significant ^{137}Cs maxima in a depth of 2 to 9 cm, depending of the sedimentation rate, which varies over the lake according to the path of the inflowing water. A second, but less significant maximum can be found 10–25 cm deep. Whereas the first maximum can be attributed to the Chernobyl input, the second one is due to the main ^{137}Cs influx due to atmospheric nuclear bomb testing around 1964. From the depth of the peak and the known time which has passed since the deposition, and neglecting the mobility of Cs in the sediment, a sedimentation velocity of 0.2–0.8 cm/a can be calculated. For the mean annual ^{137}Cs input at sampling time (1997), calculated from the activity concentration on the upper surface of the cores, we found 197 Bq/m².a (ref. 1 May 1986). Considering the area of lake Traunsee, we get an annual input of 4.9 GBq and, relating this result to the 35 TBq inventory, an erosion rate of 140 ppm per year.

The ^{137}Cs concentrations in water of different rivers were between < 0.11 and 1.6 mBq/l, the corresponding erosion rates between < 3 ppm and 48.4 ppm per year. The following table shows some results for ^{137}Cs concentrations in river water (ref. 1 Jan 1997))

TABLE 3. Estimated total erosion rates ^{137}Cs in Traun catchment area.

catchment area until reference point	area, km ²	mean spec. drainage (Mq), l/s.km ²	mean annual drainage (MQ), 10 ⁶ m ³ /a	^{137}Cs , mBq/l river water	^{137}Cs , mBq/l river water sediment	^{137}Cs -outflow, MBq/a	mean ^{137}Cs -deposition, kBq/m ² .	^{137}Cs -inventory, TBq	erosion rate, x 10 ⁻⁶ a ⁻¹
Traun / Laakirchen			2297	1.25	< 0.19	2872	50.8	75.8	44
Traun / Roitham	1491.8	48.8	2297	1.19	0.24	2734	50.8	75.8	43
Langbathbach / Ebensee	37.8	30.3	36	0.50	2.8	18	72.0	2.7	92
Traun / Ebensee	1257.9	50.9	2020	< 0.094	2.5	< 190	50.1	63.0	130
Ischl / Bad Ischl	250.9	43.7	346	< 0.092	0.97	< 32	52.2	13.1	49
Traun / Bad Ischl	752.3	54.4	1291	0.67	2.4	865	41.6	31.3	57
Gosaubach / Hallst. See	91.7			< 0.17	0.86	-	-	-	40
Waldbach / Hallstatt	41.6	78.8	103	< 0.093	< 0.26	< 9.6	42.1	1.8	
Traun / Obertraun	334.4	59.6	629	0.1	3.2	63	41.0	13.7	188
Traun / Grundlsee	125.1	48.2	190	< 0.28	0.96	< 53	42.5	5.3	19
Augstbach / Bad Aussee	10.5	46.7	15	< 0.17	< 0.07	< 2.6	41.0	0.4	9

Conclusions

Differences in landuse and the ecological characteristics of the two investigated catchments were reflected in the annual output rate of ^{137}Cs via surface waters. In the upland catchment this output is higher, and ^{137}Cs is lost mainly in dissolved form. In the alpine Traun catchment the main ^{137}Cs fraction is transferred to the hydrosphere as a result of surface erosion, thus radiocesium is bound to the particulate fraction. Sediment cores of Lake Traunsee were used to derive the ^{137}Cs loss from the catchment to deep lake bottom sediments, taking into account the vertical pattern of ^{137}Cs content in different sediment layers, time since deposition and sedimentation rates. In both catchments the annual loss rate is less than 0.01% of the soil inventory.

FORMS AND DYNAMICS OF TECHNOGENIC RADIONUCLIDES IN THE INTRASOIL FLOW IN FOREST ECOSYSTEMS

A.I. SHCHEGLOV, A.I. KLYASHTORIN, G.I. AGAPKINA,
S.V. MAMIKHIN, O.B. TSVETNOVA

Radioecology Laboratory, Moscow State University,
Moscow, Russian Federation

Abstract

Forest biota is of the key factors affecting the migration rates of ^{90}Sr and ^{137}Cs , and their possible transfer to ground water. Annual rates of the radionuclide uptake and return to the soil have a considerable effect on the radionuclide migration from the root-abundant soil layer to the ground water. The effect of soil absorbing complex and biological cycling on their migration is not as manifested as for ^{137}Cs and ^{90}Sr , and relative influx of plutonium to the ground water is more intensive compared to other radionuclides. Annual radiocaesium influx to the ground water is estimated as 0.03–0.05% of total deposition. The deposition of radiostrontium in the 30-km exclusion zone varies from 50 to 70% of ^{137}Cs deposition. It may be assumed that at least 0.1% of total deposition of ^{137}Cs and ^{90}Sr in the hydromorphic areas comes annually to the ground water. In the automorphic areas, average annual rate of radionuclides replacement from forest litter to the mineral soil layers is about 1.9–3.7%. The corresponding figure for hydromorphic forest environments is about 7%. The radionuclide content in mineral soil horizons increases monotonously with time. Annual increment of ^{137}Cs in the 5-cm mineral soil layer is about 4% in hydromorphic area and 3% in automorphic area. The corresponding rates for the 5–10-cm layer are 1 and 0.5%, respectively. Annual involvement of ^{137}Cs and ^{90}Sr into the biological cycle is much higher than their outflux from the biogeocenosis (both vertical and lateral). The large scale lateral redistribution of the radionuclides in the system of adjacent, geochemically joint landscapes does not exceed 1% per year for ^{137}Cs , and is likely to be somewhat higher for ^{90}Sr . The intensity of radionuclide redistribution at the scale of meso- and micro-topography (meters and tens of meters) may reach 10% per year.

BACKGROUND

Pollution of fresh-water resources by radioactive fallout is usually mediated by some period of radionuclide stay in the vegetation and soil cover. Nowadays, the problem of radionuclide migration from the soils to the surface and ground waters is of critical importance for the territory of Russia, Belarus', and Ukraine strictly contaminated due to the Chernobyl accident.

More than 30% of this territory is covered by forests, and there are some reasons to suppose that forest ecosystems are among main contributors of radionuclides to the ground waters. This is due to the following factors:

- Forests occupy more than 30 % of strictly contaminated territories of Belorussia, Russia, and Ukraine.
- The deposition in the forest ecosystems is usually higher than in the adjacent meadow and agrosystems
- The most proportion of radionuclides in the forest ecosystems is accumulated in the vulnerable layer of forest litter and can be easily released in case of its degradation
- Forests occupy, as a rule, the least productive sandy and boggy territories characterised by close water table and high radionuclide mobility

- Forest territories are rarely subjected to special counter-measures in order to slow down radionuclide migration

Nevertheless, forests are the least investigated environments in terms of radioecology. Radioecology Laboratory at Moscow State University has been studying the problems of radionuclide migration in the environment (primarily in the contaminated forest and other semi-natural ecosystems) since 1953. In 1986, we started the large scale radioecological studies in the territories of Ukraine and Russia exposed to the Chernobyl-born fallout.

SCOPE OF THE STUDY

- Radionuclide redistribution and retention in the components of forest ecosystems as a factor preventing their further migration
- Basic factors controlling radionuclide migration in the soil-water system and calculation of basic biogeochemical parameters of radionuclide fluxes in forest ecosystems
- Qualitative and quantitative studies on potentially mobile and available forms of radionuclides and their long term and seasonal dynamics
- Development of conceptual and mathematical models describing biological cycle of radionuclides in forest landscapes.

MATERIALS AND METHODS

Field Activities

To estimate the content, forms, and dynamics of the radionuclides migrating down to the ground water, the samples of intrasoil (lysimetrical) water, soils, and plants were collected in the territory of the 30-km exclusion zone of Chernobyl Nuclear Power Plant (ChNPP) in the May-August of 1998. The field activities were undertaken to obtain the data on the following issues:

(a) Study of lateral distribution of the radionuclides

The parameters of horizontal redistribution of radionuclides were estimated based on the changes in their general stocks in the forest joint by common soil-geochemical flux. General idea of this approach is that comparing the changes occurred to the radionuclide deposition in the elementary landscapes for the period 1986–1998, it is possible to determine the trend and rate of the large scale radionuclide redistribution in the system of geochemically interconnected landscapes (i.e., to determine the geochemical flow of radionuclides) [].

In 1998, field sampling was carried out at the key plots #1 and #2 with total ^{137}Cs deposition in 1986 of 240 and 287 kBk/m², respectively.

The key plots are located in the upper part of the watershed slope (key plot 1) and in the isolated swamped depression in the lower part of the slope (key plot 2). Both plots were established in 1986 in the frame of the long term monitoring network developed by the Laboratory in the contaminated territories of the European part of CIS in 1986–1988 [Shcheglov, *et al*, 1996, 1999].

TABLE 1. Basic characteristics of the model ecosystems

Key plot	Position relative to ChNPP	Type of ecosystem	Type of landscape	Deposition ¹³⁷ Cs (kBq/m ²)
1	28.5 km to the South	Mixed forest,	Eluvial	242
2	26.0 km to the South	Alder forest	Transit-accumulative	287
3	6.5 km to the South-East	Pine forest	Transit	2900
4	6.0 km to the West	Mixed forest	Eluvial	44730

The of forest litter and soil samples were taken from 4 soil layers at 25 sampling points distributed randomly over each key plot. First of all the forest litter was collected using the frame of 25x25 cm in area. After that, the soil samples taken from layers 0–5, 5–10 and 10–20 cm at the same points by cylindrical core sampler with the cross-area of 54 cm². Totally 100 samples of soils and forest litter were collected.

To take into account the changes in total deposition in the joint elementary landscapes, ¹³⁷Cs accumulated in the vegetative cover has been estimated by sampling of arboreal and herbaceous vegetation at the key plots.

Sampling of the arboreal vegetation was made using the so-called "model tree" method. The representatives of dominant tree species most corresponded to average basic parameters of these species in the investigated ecosystem were sawed down and separated into the main structures (leaves or needles, branches, bark, wood, generative organs, etc.). Bark and wood samples were taken threefold: from the tree basement, middle part of the trunk, and the trunk top.

The samples of herbal layer were collected using special frame with cutting area of 50x50 cm (5–10 replication for each plot).

The biomass of all sampled components of the vegetation was determined by weighting, with further recalculation into the dry weight. Totally, 125 vegetative samples were collected.

(b) Study of vertical distribution of the radionuclide in the soil profile

Studies of the vertical distribution of radionuclides in the soil profile were carried out at four key plots with ¹³⁷Cs deposition from 240 to 45000 kBq/m². All the plots are also serve as a part of the long term radiological monitoring network [The Behavior...,1996].

The parameters of vertical redistribution of radionuclides were estimated based on the following approaches: (1) by determination of the long term changes in the radionuclide content in different soil layers, and (2) by direct measuring of the radionuclide fluxes in the vertical intrasoil flow (lysimetrical study).

In case (1), soil and forest litter samples were collected in 15-fold replication. Different layers of forest litter (l, f, and h) were collected separately. Mineral soil samples were collected using the same cylindrical core, with a section of 1 cm for the layer 0–9 cm, 2 cm for the layer 10–15 cm, and 5 cm for the layer 40–60 cm. Maximum depth of sampling depended on the deposition and expected depth of radionuclide penetration to the soil.

In case (2), the radionuclide flux was measured by lysimeters established in 1989 at 4 key plots by depths 5, 10, 20, and 30 cm, in 3–4-fold replication [Klyashtorin, et al.,]. The area of each lysimeter was of 0.12 m². The samples were collected monthly by pumping of the lysimetrical water from the collectors.

(c) Study of physico-chemical forms of radionuclides in the liquid soil component

Studies in this field included field sampling and laboratory experiments. The soil samples were taken at 3 plots (Table 1, #1, #3, and #4) by 5 layers: forest litter horizons A0l (0–1 cm), A0f (1–2 cm), and A0h (2–4 cm); transition horizon A0/A1 (4–5 cm); and humus horizon A1 (5–10 cm) using threefold replication for each layer. In some cases, the samples of deeper layers of were collected as well. The samples were placed into plastic bags, cooled to 5–7 °C, and transported to the laboratory for further treatment (see section Laboratory activities).

LABORATORY ACTIVITIES

(a) Preparation and measurements of the soil samples

All soil and vegetative samples (excluding ones intended for further treatment) were weighted, dried at 105° C, and homogenized by grinding. The volume of lysimetrical water was measured, and then the samples were concentrated by evaporation [Klyashtorin, et al., 1994]. The samples were analyzed using Gamma-spectrometer DGDG-100. ⁹⁰Sr was measured using the standard radiochemical methods. Totally 310 samples of soils and vegetation have been analyzed.

(b) Isolation of the mobile forms of radionuclides and separation them into molecular fractions

The soil solution was isolated by centrifugation of the soil samples previously added with water. Distilled water was added to each soil sample to make the soil moisture equal to 60% of its maximum water capacity. The samples were incubated for one week and than centrifuged (4h, 6000rpm). With respect of the total water content, the percentage of soil solution obtained in this way was 53–70% (depending on soil sub-horizon). The relative content of radionuclide in each individual horizon of the litter or mineral layer was expressed as the ratio of radionuclide content in the soil solution to the total content of this radionuclide in the soil sample. The relative radionuclide content in the soil liquor for the total contaminated layer (including all the contaminated sub-horizons) was calculated using the following equation:

$$RC_{\text{total}} = \text{SUM} (RC_i * n_i),$$

where RC_i is the relative content of some radionuclide in the soil solution of sub-horizon i ; n_i - is the radionuclide fraction in the sub-horizon i of its total content in the contaminated layer. The content of the ¹³⁷Cs, was measured by direct gamma spectrometry [The Behavior..., 1996]. The content of ⁹⁰Sr was measured by the radiochemical method [Shcheglov, 1999].

RESULTS AND DISCUSSION

1. Physico-chemical forms of radionuclides in the soil liquor

The information on the content and composition of radionuclides in the soil liquors is vitally important for reliable estimation, prediction, and elaboration of the preventive measures to control radionuclide vertical migration in the soil and possible penetration to the aquifers.

It was found that the relative radionuclide content in the soil liquors is quite low: from 0.04 to 2.1% of their total deposition. This parameter depends on physico-chemical nature of radionuclides, type of ecosystem, and depth. The proportion of some radionuclide in the radionuclide composition can be ranged as the following: $^{90}\text{Sr} > ^{137}\text{Cs} > ^{239+240}\text{Pu} > ^{241}\text{Am}$ (Table 2.). The content of water-soluble fractions of $^{238-240}\text{Pu}$ and ^{241}Am increase down the soil profile. For ^{90}Sr and ^{137}Cs , this value is maximal in the humus sub-horizon of the forest litter and minimal in the first mineral layer of the investigated soils.

TABLE 2. Relative content of radionuclides in the soil liquors of different horizons of forest soils (% of total deposition; key plot #4)

Horizon	^{90}Sr	^{137}Cs	$^{239+240}\text{Pu}$	^{238}Pu	^{241}Am
AOf	1.1	0.31	0.043	0.057	0.042
AOh	0.49	0.039	0.078	0.065	0.046
A0h+A1(A2)	1.7	0.075	0.22	0.14	0.44
Total contaminated soil layer	0.65	0.14	0.066	0.063	0.045

Most proportion (60–98%) of the radionuclides contained in the soil liquid component is associated with the fractions of organic matter with molecular masses (MM_w) from 350 to 1800Da. (Table 3). Different radionuclides are primarily associated with different molecular fractions. Thus, 43% of ^{90}Sr is bound with low-molecular fraction (MM_w of 350–500 Da) and 33–40% of this radionuclide is associated with inorganic fractions (< 350 Da). From 55 to 93% of ^{137}Cs are primarily associated with heavier fractions (> 1000 Da), and 72–96% of plutonium and americium isotopes are associated with the heaviest fractions of soluble organic matter (13000–15000 Da).

These data explain relative mobility of different radionuclides in the soil liquors, intrasoil flow and other liquid environment. Migration ability and biological availability of soluble metal-organic associates, (and radionuclide-organic as well) is reported to be inversely proportional to the molecular weight of the associates [Agapkina, 1994, 95].

Type of ecosystem has some effect on the soluble radionuclide associates distribution by molecular fractions. The proportion of ^{137}Cs associated with the fraction > 1000 Da was found to be higher in Pine forest (#3) compared to mixed ones.

The long term dynamics of the relative content of ^{137}Cs in the soil liquors (recalculated to the total contaminated layer) is characterized by well-manifested minimum in 1987–1991 followed by rather stable period (Table 4).

In general, the following processes determine radionuclide behaviour in the soil liquid components:

TABLE 3. Radionuclide content in different fractions of the soil liquor (%)

Molecular weight of the radionuclide-organic compounds (Da)	⁹⁰ Sr			¹³⁷ Cs				
	Mixed forest			Mixed Forest			Pine forest	
	Layer							
	A0h	A1(A2)	A0f	A0h	A0h+A1(A2)	A1(A2)	A0f	A0h
>18000	-	-	-	-	-	-	5	4
13000-15000	4	-	31	16	8	11	43	31
5400-6600	3	-	8	12	12	21	6	11
2800-3500	-	-	4	12	13	6	28	30
900-1100	10	8	46	30	25	16	11	7
350-500	43	59	3	21	23	22	4	12
Inorganic	40	33	7	9	19	24	3	5
	²³⁹⁺²⁴⁰ Pu (²³⁸ Pu)			²⁴¹ Am				
	Mixed forest			Mixed forest				
	A0f	A0h	A0h+A1(A2)	A0f	A0h	A0h+A1(A2)		
>2000	72(62)	66(58)	70(88)	68	49	34		
1300-1000	19(24)	21(26)	26(3)	9	23	17		
800	4(4)	8(9)	1(3)	13	9	8		
400	2(3)	3(2)	1(3)	4	6	13		
Inorganic	3(7)	2(5)	2(3)	6	13	28		

TABLE 4. Long term dynamics of ¹³⁷Cs relative content in the soil liquors as recalculated to the total contaminated soil layer (%)

Plot	1987	1988	1989	1990	1991	1993	1994	1998
#1	2.1±0.3	1.0±0.02	0.41±0.08	0.64±0.09	0.59±0.09	0.58±0.08	-	0.74±0.09
#3	0.30±0.06	0.62±0.09	0.15±0.04	0.41±0.08	0.27±0.06	0.35±0.07	0.32±0.06	0.38±0.07
#4	0.8±0.2	0.11±0.03	0.09±0.03	0.16±0.04	0.22±0.06	0.10±0.02	0.14±0.04	0.06±0.01

- Radionuclide leaching (release) from the fallout particles in the forest litter horizons
- Vertical migration of the radionuclides through the soil (forest litter) layers
- Absorption of the radionuclides in the humus horizons of the forest litter and soil (A0H, A0/A1, A1).

The data on ¹³⁷Cs content in the soil water in 1998 are in agreement with our previous data (1988–1994). Thus, RC value in the transit and first mineral horizon of soil (A0/A1) continue to decrease (Fig.1, Table 5).

These data confirm the processes of active absorption of ¹³⁷Cs in this part of the soil profile. The process is especially pronounced in soil at the key plot #4 characterized by high content of humus, clay minerals, and silt fraction. This plot is also characterized by gradual decrease in the relative content of radionuclides in the soil liquor as recalculated to the total soil, whereas for other plots this parameter stays practically stable.

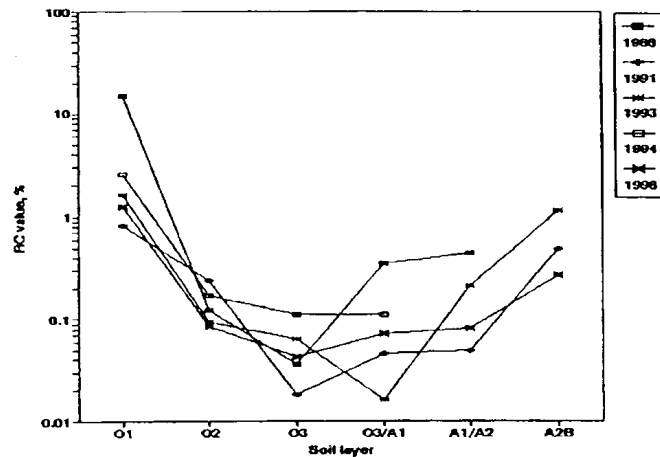

Fig.1. Relative content of ^{137}Cs in the liquors from different soil and forest litter horizons

TABLE 5. The dynamics of ^{137}Cs relative content in the liquors from different soil layers (%)

Horizon	Plot #	Depth	1987	1988	1989	1990	1991	1993	1994	1998
A0l	1	0-0.5	1.83	0.84	1.22	1.20	0.90	7.30	16.00	1.85
	3	0-1	-	14.00	0.82	0.37	0.28	4.07	0.29	4.20
	4	0-0.5	-	15.10	0.44	0.61	0.82	1.62	2.56	1.25
A0f	1	0.5-2.5	3.80	1.30	0.42	0.74	0.68	0.64	0.62	0.72
	3	1-4	0.22	0.24	0.10	0.42	0.25	0.44	0.37	1.40
	4	0.5-2.5	1.10	0.12	0.08	0.12	0.24	0.09	0.17	0.09
A0h	1	2.5-4.5	2.70	0.34	0.18	0.41	0.34	0.21	-	0.66
	3	4-6	0.70	0.13	0.07	0.08	0.12	0.13	0.18	0.11
	4	2.5-4.5	0.07	0.04	0.03	0.05	0.02	0.06	0.11	0.04
A0h/À1	1	4.5-6	-	3.30	1.70	0.23	0.20	2.42	1.29	0.22
	3	6-7	0.84	2.10	0.42	0.57	0.60	0.12	0.45	0.10
	4	4.5-5.5	0.02	0.07	0.14	0.05	0.05	0.02	0.11	0.07
À1/À2	1	6-7	-	-	-	1.45	1.20	-	-	6.70
	3	7-11	3.00	6.80	1.70	-	0.80	1.32	2.20	0.20
	4	5.5-9.5	0.14	0.44	0.29	0.25	0.05	0.21	-	0.08
À2À	1	7-13	no data							
	3	11-16	17.60	-	-	-	-	5.16	-	-
	4	9.5-14.5	1.10	-	1.70	4.40	0.48	1.13	-	0.27
À2À	1	13-20	no data							
	3	16-22	no data							
	4	14.5-19.5	0.42	-	0.64	-	-	1.50	-	-

2. Radionuclide distribution among the components of forest ecosystems

The most characteristic feature of forest ecosystems is pronounced (up to 90%) and long term (more than 10 years long) retention of the radionuclides incorporated within the living organisms (biota). Therefore, vertical migration of the radionuclides in the forest soils and intensity of their influx to the ground waters depend on the peculiarities of their accumulation in the forest biomass. To estimate the effect of this factor on the integral process of radionuclide migration, it is necessary to study the radionuclide accumulation separately in each component of forest ecosystems.

The research have been carried out using long term key plots with ^{137}Cs deposition from 0.2 to 40 MBq/m² and our data from other key plots established in the course of our earlier researches. Total arboreal phytomass was determined directly and calculated using our field data and standard mathematical dependence between different structural components of the tree species characteristic for the investigated region [Basilevich et al., 1978, Myakushko, 1978].

The inventory of the organic matter in grass vegetation and moss cover (understory) was determined with the method of cutting areas using necessary replication [Shcheglov, et al., 1996]. The underground phytomass was assumed to be of 35% of the above ground phytomass, which is a common assumption in the studies of biological production in phytocenoses [Basilevich et al., 1978]. The biomass of higher fungi in the investigated ecosystems was estimated from the data on average annual production of fungi in the forests of the moderate zone [Burova, 1991]. The biomass of the fungi mycelium was determined directly on the key plots by [Mirchik, 1988]. Radionuclide content in the components of forest ecosystems was determined using the methods described in our previous report and other original publications [Shcheglov, et al., 1996 Tsvetnova, et al., 1996].

Spatial heterogeneity of the radionuclide distribution among tree components

Radionuclide content in the tree components is characterized by high heterogeneity. Within the plots possessing with well manifested microtopography (1–5*10¹ cm) and mesotopography (0.5–2*10² cm), ^{137}Cs concentration in the same structural part (organ) of a tree may vary by more than one order of magnitude (Table 6). The corresponding variation for different organs may be as high as 3 orders of magnitude.

^{90}Sr content in the pine organs is characterized by higher heterogeneity than ^{137}Cs : its variation coefficient is 1.5–2 times higher. In general, the variation of ^{90}Sr content is almost inversely proportional to this index for ^{137}Cs . Such a high variability of both ^{137}Cs and ^{90}Sr has to be taken into account when calculating their inventory, and the capacity and intensity of the biological cycle of these radionuclides.

Arboreal vegetation in the plots with homogenous growth conditions (relatively plane micro- and mesotopography) is characterized by lower variation of the radionuclide concentration in the tree organs (even taking into account the interspecies variation) (Table 7). In fact, the variation indices in this case are close to these characteristics for the soils in the investigated territory (see below).

The latter is well manifested for ^{137}Cs and less pronounced for ^{90}Sr . This suggests that the accumulation (and retention) of radionuclides by arboreal vegetation even within the relatively small area depends most on the variation of their growth conditions (soil properties, moisture regime, and other ecological factors). The effect of these factors on the soil-plant system is most characteristic for ^{137}Cs and less pronounced for ^{90}Sr .

Spatial heterogeneity of the radionuclide distribution in the soil

Direct measurements of the radionuclide content in the soil showed that the radionuclide inventory in different soil layers depends primarily on the distance from the accidental unit and varies depending on a range of soil parameters.

Statistical indices of spatial heterogeneity of ^{137}Cs content over the key plots in the investigated territory varies from 22 to 32% (Table 8).

TABLE 6. Statistical indices for the concentration of ^{137}Cs and ^{90}Sr in the organs of *Pinus Sylvestris* in the plot with pronounced micro- and mesotopography (kBq per kg of dry matter, n = 26-42)

Organs	Statistical indices					
	M	$\pm m$	max	min	G	V, %
^{137}Cs (deposition by ^{137}Cs is of 4547 kBq/m ²)						
Wood (barked)	5.0	0.47	10.4	0.52	3.1	61.5
Bark:						
Internal (alive)	53.1	5.20	152.9	8.88	33.8	63.6
External (cork)	38.6	4.00	114.7	18.87	25.9	67.2
Branches:						
Large (d>5β¼)	10.9	1.14	35.5	2.22	7.3	66.9
Small (d<1β¼)	19.5	1.80	44.4	3.15	11.5	58.9
Old needles	17.7	1.77	48.1	2.63	11.5	64.9
Needles of current year	16.7	5.76	144.3	10.73	35.4	57.7
Cones	46.1	6.47	136.9	8.14	36.0	78.2
^{90}Sr (deposition by ^{90}Sr is of 2919 kBq/m ²)						
Wood (barked)	5.9	1.17	35.3	0.67	7.6	127.8
Bark:						
Internal (alive)	29.4	4.64	155.4	4.11	30.1	102.6
External (cork)	21.3	3.98	99.9	3.03	25.8	121.1
Branches:						
Large (d>5β¼)	12.3	2.00	51.8	1.71	12.9	107.5
Small (d<1β¼)	15.7	3.18	92.5	0.59	20.6	130.8
Old needles	15.2	3.40	88.5	1.04	22.0	145.5
Needles of current year	12.1	2.91	77.7	0.67	18.2	149.7
Cones	0.6	0.98	1.8	0.08	0.4	65.8

Key: **M** is the arithmetical mean; **$\pm m$** is the mean error; **G** - standard deviation; **max** and **min** - are maximum and minimum values, respectively; **V** - is the variation coefficient, %

The variability decreases as the distance from the CHIP increases. In the territory of the exclusion zone, the differences between the **max** and **min** indices are by an order in magnitude higher than these in the more distant territories (Russian Federation).

Type of ecosystem has a significant effect on the variation of ^{137}Cs content in the soils. Maximum and minimum variation coefficient of this indexes are characteristic for young pine forests and mixed forests, respectively. The differences in the variation coefficients are likely due to the effect of ecosystem features on the processes of initial and secondary distribution of the radioactive fallout in forests.

Spatial heterogeneity of the radionuclide content varies down the soil profile, and automorphic and hydromorphic landscapes are different by the manifestation of the variation. In the automorphic landscapes, spatial heterogeneity increases sharply with depth, and the variation coefficient is minimal in the upper horizon (forest litter) (Fig. 2, Table 9.).

TABLE 7. Statistical indices for the concentration of ^{137}Cs and ^{90}Sr in the tree organs in the plot with unpronounced micro- and mesotopography (kBq per kg of dry matter, n = 9)

Tree organs	Statistical indices					
	M	$\pm m$	max	min	G	V, %
^{137}Cs (deposition = 139 kBq/m ²)	0.029	0.003	0.043	0.017	0.008	27.6
Wood (barked)						
Bark:						
(internal + external)	0.467	0.161	1.643	0.093	0.484	103.5
Branches:						
(large + small)	0.075	0.012	0.115	0.032	0.030	39.6
Assimilative organs (leaves and needles)	0.155	0.030	0.215	0.083	0.059	37.9
^{90}Sr (deposition = 73 kBq/m ²)	0.174	0.067	0.648	0.015	0.201	115.7
Wood (barked)						
Bark:						
(internal + external)	0.703	0.149	1.567	0.135	0.446	63.5
Branches:						
(large + small)	1.086	0.563	3.827	0.108	1.378	126.8
Assimilative organs (leaves and needles)	0.932	0.660	3.217	0.083	1.320	141.6

Key: **M** is the arithmetical mean; $\pm m$ is the mean error; **G** - standard deviation; **max** and **min** - are maximum and minimum values, respectively; **V** - is the variation coefficient, %

TABLE 8. Spatial heterogeneity of ^{137}Cs deposition in the forest soils, kBq/m²

Region	Statistical indices						
	n	M	$\pm m$	max	min	G	V, %
Tula, Russia	16	337	19.6	507	226	78.4	23.3
Kaluga, Russia	24	355	80.3	492	252	22.2	22.6
Bryansk, Russia	26	1144	102	2331	570	418	28.2
Exclusion zone of ChNPP, Ukraine	289	3826	70.7	9990	414	1199	32.4

Key: **M** is the arithmetical mean; $\pm m$ is the mean error; **G** - standard deviation; **max** and **min** - are maximum and minimum values, respectively; **V** - is the variation coefficient, %

TABLE 9. Statistical indices of the ^{137}Cs content in the soils of automorphic and hydromorphic landscapes (the exclusion zone, kBq/m²)

Layer (cm)	M	$\pm m$	G	max	min	V, %
0	3826	71.7	1199	9990	407	31.0
0-5	674	30.3	514	4810	62.9	76.2
5-10	62.2	4.07	68.1	703	4.81	109.3
0-10	728	30.7	521	4909	73.3	72.0
0+(0-10)	4547	68.1	1158	10452	855	25.0

Key: **M** is the arithmetical mean; $\pm m$ is the mean error; **G** - standard deviation; **max** and **min** - are maximum and minimum values, respectively; **V** - is variation coefficient, %

The data suggest that the intensity of vertical radionuclide migration in soddy-podzolic sandy soils of automorphic landscapes is extremely variable and so the downward movement of the radionuclide is not front-like. Thus, the lower boundary of their profile distribution is very irregular and radionuclide migration is likely to run in local vertical micro-zones. The influx of radionuclides to the ground waters is the most probable in these microzones.

In the soils of hydromorphic landscapes, the variation of the statistical indices down the profile are insignificant, which is an evidence of the frontal distribution of ^{137}Cs in the soil (Fig. 1). This is due to the accelerating effect of high moisture (characteristic for these soils) on the processes of convective and diffusion transfer of the radionuclides [Loshchilov, et al., 1993, Filep et al., 1986]. These soils have also a high proportion of soluble organic matter that intensifies the migration ability of ^{137}Cs , ^{90}Sr and other radionuclides by forming mobile radionuclide-organic compounds [Agapkina, 1994]. Besides that, organic horizons of these soils are almost devoid of clay minerals, and their cation-absorbing capacity is almost completely limited by ion-exchange mechanisms [Barber, 1988].

Radionuclide redistribution among the components of forest ecosystems

General evaluation of relative redistribution of the radionuclides among the ecosystem components show that both soil-absorbing complex and soil biota are the basic factors preventing the radionuclides from fast transfer to the upper aquifers (Table 10, 11).

The contribution of biota as a factor preventing radionuclides from downward migration is not the same in different landscapes. According to our data, from 9 to 65% of ^{137}Cs and from 9 to 21% of ^{90}Sr is retained (incorporated) in the biota.

The biota plays the key role under hydromorphic conditions, while the soil absorbing complex prevails in radionuclide retention under automorphic conditions. The contribution of biota in this respect depends much on the nature of a radionuclide. Its effect is more pronounced for ^{137}Cs compared to ^{90}Sr .

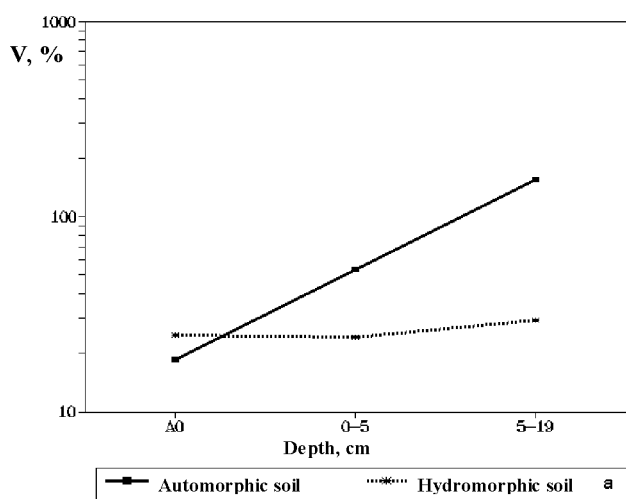

Fig. 2. Coefficient of variation (V , %) of ^{137}Cs content in the profile of automorphic and hydromorphic forest soils.

TABLE 10. Distribution of ^{137}Cs among the components of forest ecosystem (1998)

Key plot # *	Components					
	Arboreal vegetation	Herbaceous vegetation.	Moss cover	Fungi complex	Soil	TOTAL
Inventory, kBq/m²						
1	3.7	0.22	0.93	7.2	131.8	143.8
2	23.7	1.15	8.45	84.8	61.6	179.7
3	49.0	1.22	28.5	348.1	1556	1983
4	876.0	38.90	170.0	3749.4	17660	22494
Relative contribution (% of total)						
1	2.6	0.2	0.6	5.0	91.6	100
2	13.2	0.6	4.7	47.2	34.3	100
3	2.5	0.1	1.4	17.5	78.5	100
4	3.9	0.2	0.7	16.7	78.5	100

* See Table 1

TABLE 11. Distribution of ^{90}Sr among the components of forest ecosystem (1998)

Key plot # *	Components					
	Arboreal vegetation	Herbaceous vegetation.	Moss cover	Fungi complex	Soil	TOTAL
Inventory, kBq/m²						
1	10.18	2.02	-	0.14	72.85	85.19
2	15.29	0.43	-	0.06	60.9	76.68
3	180.0	8.5	-	0.10	866.9	1055.5
4	1300.6	19.5	-	0.62	13285	14605.7
Relative contribution (% of total)						
1	11.9	2.4	-	0.2	85.5	100
2	19.9	0.6	-	0.1	79.4	100
3	17.1	0.8	-	< 0.1	82.1	100
4	8.9	0.1	-	< 0.1	91.0	100

* See Chapter 1

It must be emphasized that the contribution of different components of the ecosystem biota to the retention of radionuclide and prevention of their migration to the ground waters depends on radionuclide. Fungus complex is the key ecosystem component retaining ^{137}Cs (fungi may accumulate up to 47% of its total deposition), and for ^{90}Sr , the key component is arboreal vegetation that incorporates up to 20% of the deposition.

Thus, in forest ecosystems, biological cycle is one of the key factors determining the mobility and migration ability of ^{90}Sr and ^{137}Cs , and their transfer to the upper aquifer (ground waters). Therefore, annual consumption and return of these radionuclides by individual components of biota should be studied in more detail to estimate quantitative parameters of annual radionuclide migration from the root-abundant soil layer to ground waters depending on ecosystem and landscape type.

Special problem is vertical migration of plutonium isotopes. Our preliminary studies suggest that the effect of soil absorbing complex and biological cycling on the migration of this radionuclide is not as manifested as in the case of ^{137}Cs and ^{90}Sr [Shcheglov, 1999]. Therefore, relative influx of plutonium to ground waters is expected to be more intensive compared to other radionuclides.

We believe that our future work in the frame of this Project shall be focused on the estimation of annual fluxes of ^{137}Cs and ^{90}Sr in the system “soil-plant-ground waters” and behavior of plutonium isotopes taking into account all ecosystem components and landscape conditions.

3. Vertical Distribution of ^{137}Cs in the soils

Radionuclide distribution down the soil profile determines at a large extent radiological situation in forest ecosystems, and is one of the most influential factors of their biological availability and accumulation in the plants. Vertical migration of radionuclides in forest ecosystems is very variable and depends on several transports [Il'in, 1989, Petryaev 1990, Tsvetnova,1996]. Specific structure of forest soils makes it reasonable to analyze the processes of radionuclide migration separately in the forest litter (A0) and mineral horizons.

Radionuclide content and dynamics in the forest litter

Forest litter is known to be a very important factor of spatial and temporal behavior of all chemical elements in forest ecosystems. [Alexakhin, 1997, Karpachevskii, 1981, Tikhomirov, et al., 1990]. A most informative index of the radionuclide vertical migration the distribution of the deposition among the mineral soil layers and forest litter. Maximum retention capacity of the soil litter in these forest types is determined by two factors:

1. Low transformed organic matter and low content of mineral component [Rozanov, 1983]. These features, along with the thick organic layer lead to the capillary rapture and slow down water and element exchange within the forest litter, which promotes radionuclide retention in the layer.
2. Accumulative capacity of soil biota (particularly microorganisms) is most pronounced in coniferous cenoses. Fungus mycelium is known to be a very effective accumulator of radionuclides, and mycobiota may contain 10 to 60% of total ^{137}Cs inventory in the soil [Dighton, 1988, Yoshida, 1994].
3. Well-developed moss cover over the forest litter promotes radionuclide retention in the upper organic layer (Table 12). This is due to the above mentioned capability of mosses (lichen) for effective accumulation of radionuclides.

The rates of annual radionuclide migration and transport to the mineral soil layers presented in Table 13 are calculated from the radionuclide distribution of 1995–96 (on the average, over 70% of the deposition that time was still concentrated in the forest litter).

TABLE 12. The effect of moss cover on the retention capacity of the forest litter (by Shcheglov, 1999)

Ecosystem	Thickness of the forest litter (cm), Presence of the moss cover*	Layer	^{137}Cs , % (**)
Mixed, broad-leaved/pine forest	4.5 (+)	Forest litter	50.9
		Mineral layers	49.1
Pine forest	3.5 (-)	Forest litter	35.3
		Mineral layers	64.7
Pine forest	4.4 (-)	Forest litter	35.7
		Mineral layers	64.3
Pine forest	4.3 (+)	Forest litter	59.9
		Mineral layers	40.1

* (+) moss cover in well pronounced ; (-) moss cover is absent; ** %of total inventory in the soil profile

TABLE 13. Long term dynamics of ^{137}Cs redistribution among forest litter (A0) and mineral layers (ML) of forest soils (% of total content in the entire soil profile)

Key site	Layer	Years								
		1987	1988	1989	1990	1991	1992	1994	1995	1999
1	A0	93.9	92.9	92.4	88	83	80.4	68.9	66.3	65.5
	ML	6.1	7.1	7.6	12	17	19.6	31.1	33.7	34.5
2	A0	93.4	88.2	85.6	74.6	66.4	58.3	60.1	51.3	38.4
	ML	6.6	11.8	14.4	25.4	33.6	36.7	39.9	48.7	61.2
3	A0	97.4	95.9	91.8	90.4	89.9	90.5	86	82.6	60.4
	ML	2.6	4.1	8.2	9.6	10.1	9.5	14	17.4	39.6
4	A0	94.1	91	93.3	91.6	88.2	86	82.8	81.5	71.8
	ML	5.9	9.0	6.7	8.4	11.8	14	17.2	18.5	28.2

In the automorphic areas, the average rate of total annual replacement of the radionuclides from forest litter to the mineral soil layers in Ukrainian Poles' is about 1.9–3.7%. The corresponding figure for hydromorphic forest environments is about 7% for the entire contaminated territory.

Radionuclide content and dynamics in mineral soil layers

The most recent data on vertical distribution of radiocesium in the investigated soils are presented in Fig. 3 In automorphic soils, ^{137}Cs is retained in the first 1–2 cm of the mineral profile. In deeper layers, the radionuclide content in the soil decreases drastically and reaches the background level at the depth of 30–70 cm depending on total deposition. I.e., 10 years after the deposition, maximum depth of radiocesium significant penetration to the soil in the automorphic areas varies within this range (30–70 cm).

In hydromorphic soils, the intensity of radionuclide migration is about 2–3 times higher than in the automorphic soils, and their distribution has a range of specific features. The radionuclide concentration decreases with depth much smoother, and the radionuclide accumulation under the forest litter is not as pronounced as in the automorphic soil. This is likely due to weak irreversible absorption of ^{137}Cs in the peat or peat-enriched upper horizons of hydromorphic soils. In the latter, maximum migration rate of ^{137}Cs is characteristic for the soils under alder forests.

Hydromorphic soils are often attributed to the topographical depressions with high water table (floodplains, bogs, plate-like depressions, etc.). High rates of vertical radionuclide migration in the hydromorphic areas makes the latter to be preferable objects for radioecological monitoring, where significant portion of radionuclides may enter ground water ("critical areas").

Unlike forest litters, the radionuclide content in mineral soil horizons increases monotonously with time. Annual increment of ^{137}Cs in the 5-cm mineral soil layer is about 4% in hydromorphic area and 3% in automorphic area. The corresponding rates for the 5–10-cm layer are 1 and 0.5%, respectively.

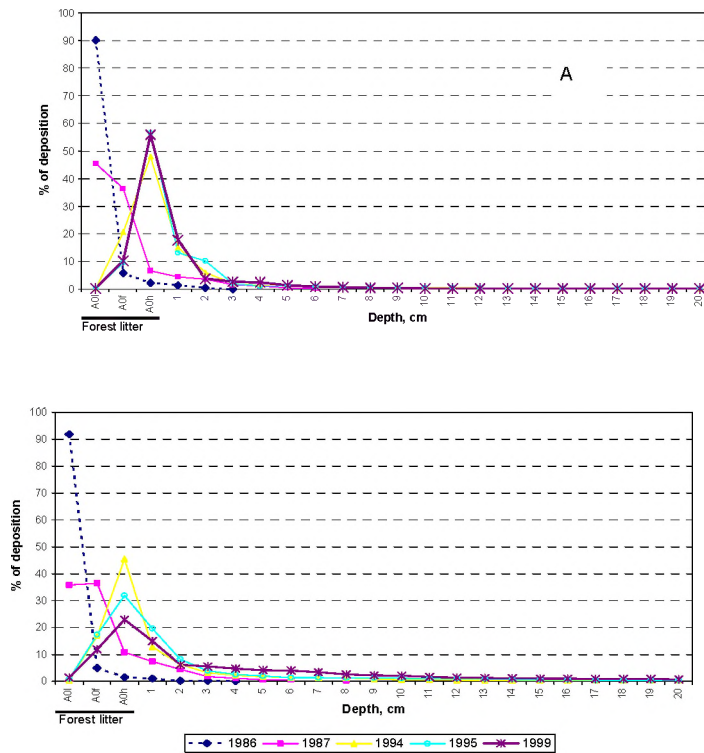

Fig 3. The dynamics of vertical migration of ^{137}Cs in (A) automorphic and (B) hydromorphic areas (key plots 1 and 2, respectively).

The rate of vertical redistribution of the radionuclides depends on a number of pedogenetic processes, and various factors and indices may set the pace depending on soil properties, weather conditions and time after the accident. Specific feature of all forest soils is the presence of forest litter horizon (A0). The latter is another one factor complicating the radionuclide behavior in these soils. In this connection, the migration models based on diffusion and convection processes and adequately describing the radionuclide behavior in forestless areas are not necessary applicable to other regions even in the case of the same soil type. To describe and predict the radionuclide migration down the soil profile in the forest environments, the forest litter and mineral soil profile shall be considered separately, since radionuclide migration and retention in these layers are controlled by different factors and processes.

Vertical distribution of ^{90}Sr in the investigated soils

The $^{137}\text{Cs}/^{90}\text{Sr}$ ratio varies over the investigated territory from 1.7–2.2 (in the exclusion zone) up to 42 in the remote zone of RF, which is due to the composition of the initial fallout [Izrael, 1987]. Vertical distribution of ^{90}Sr in the soil is generally similar to ^{137}Cs . The distribution of ^{90}Sr , however, has some specifics. Normally, higher portion of ^{90}Sr compared to ^{137}Cs is transferred from the forest litter to mineral layers. The accumulation of this radionuclide in the first mineral layer is less manifested than ^{137}Cs , and vertical distribution of ^{90}Sr down the mineral profile is smoother. These facts suggest that the distribution of ^{90}Sr is more dependable on the mass transport than ^{137}Cs , which is due to different chemical properties of these radionuclides [Molozhanova, 1989, Spiridonov, 1996]. Unlike ^{137}Cs , most

proportion of ^{90}Sr in the "solid-liquid" soil system is represented by its exchangeable, i.e., potentially mobile forms [Kruglov, 1997, Molchanova, 1991]. Therefore, ^{90}Sr migration down the soil profile with intrasoil water flow is more intensive, ^{90}Sr is distributed more uniformly, and penetrates deeper compared to ^{137}Cs .

^{90}Sr is believed to form intimate radionuclide-organic mobile compounds with fulvic acids (see chapter 2 of this report), which promote its migration ability. In addition, higher hydrolytic acidity of these soils decreases absorption of ^{90}Sr by the soil solids [Pavlotskaya, 1974]. The effect of low-molecular soluble organic products of decomposition of fresh litterfall and forest litter also affect the migration activity of radiostrontium [Tyuryukanova 1982, Chebotina, 1973].

The soil moisture regime has a considerable effect on vertical distribution of ^{90}Sr (Fig. 4). In hydromorphic soils, the portion of ^{90}Sr replaced from the forest litter to mineral layers is 1.5 times larger than in the automorphic soils.

In general, the soils in the region are extremely poor of clay minerals, which promotes relatively high mobility of ^{137}Cs . Organic horizons of the soils are capable for ^{90}Sr retention rather than ^{137}Cs [Juo, 1969, 1970]. Both the above mentioned factors promote the ^{137}Cs mobility and reduce ^{90}Sr mobility. It may be supposed, however, that as soon as a considerable portion of ^{90}Sr penetrates to deeper soil horizons, the rate of its vertical migration (up to the water table) may increase dramatically, since deeper soil layers are practically devoid of any geochemical barrier for ^{90}Sr .

Thus, both ^{90}Sr and ^{137}Cs are rather similarly distributed down the profile of the investigated forest soils on fluvioglacial sands. Their migration depends primarily on the same processes: diffusion and biogenic transport.

At the same time, migration of ^{90}Sr is more dependable on the mass transport with intrasoil water flow compared to ^{137}Cs . With other conditions being equal, higher intensity of ^{90}Sr migration is characteristic for pine forests in hydromorphic areas.

4. Radionuclide transport by infiltration (vertical intrasoil flow)

Vertical intrasoil flow is the part of soil water that filters down through the soil profile under the effect of gravitation force. Estimation of the rate and proportion of radionuclide transfer to upper aquifer is necessary to information on the intrasoil flow, since it is the most mobile component of the soil liquor.

Lysimetric studies are used to estimate vertical intrasoil flow under natural condition and get the samples of this soil component for analyses. Use of lysimeters makes it possible to obtain direct information on radionuclide mobility and their transport to upper aquifers.

Lysimetric studies were carried out at the long term monitoring plots 1-4 (see above) within the boundaries of the exclusion zone. The lysimeters (0.12 m² in area) filled with neutral drainage were established under the forest litter and into different soil layers. The water was periodically (monthly or two-monthly) pumped out from the underground collectors, concentrated, and measured for radionuclide content. The method was described in detail in our previous publications [Klyashtorin, 1994].

Concentration of ^{137}Cs in the lysimetric waters

Table 14 suggests that the radionuclide concentration in the intrasoil flow, depends on, but is not directly proportional to the deposition. The radionuclide mobility in the soils is determined by several competing processes, such as leaching from the fallout particles, absorption in the solid phase, incorporation within biota, etc. Thus, the radionuclide content in the lysimetric water depends on both physico-chemical properties of the initial fallout, and soil and other environmental parameters. Some recent studies showed that the significance of the latter factor increases with time [Shcheglov, 1996].

Numerous publications (including ours) suggest that in the forests of Russia, Ukraine, and Belarus, forest litter still serves as the main sink for Chernobyl-derived radionuclides [The Behavior..., 1996., Shcheglov, 1999]. It is the key factor affecting the formation of vertical radionuclide flow in the profile of forest soils: lysimetric waters from the forest litter are characterized by highest content of radionuclides.

In the underlying soil layers (5–10, 10–20, and 20–30 cm), ^{137}Cs is absorbed from the intrasoil flow, and only some part of the radionuclides leached down from the forest litter comes with intrasoil flow deeper than 20–30 cm. The layers 5–20(30) cm may absorb of 20 – 97% of ^{137}Cs previously contained in the waters from the layer 0–5 cm (forest litter). The maximum interception of this radionuclide takes place in the automorphic soddy-podzolic soils (plot 4), and the minimal interception occurs in the hydromorphic peat soils (plot 2).

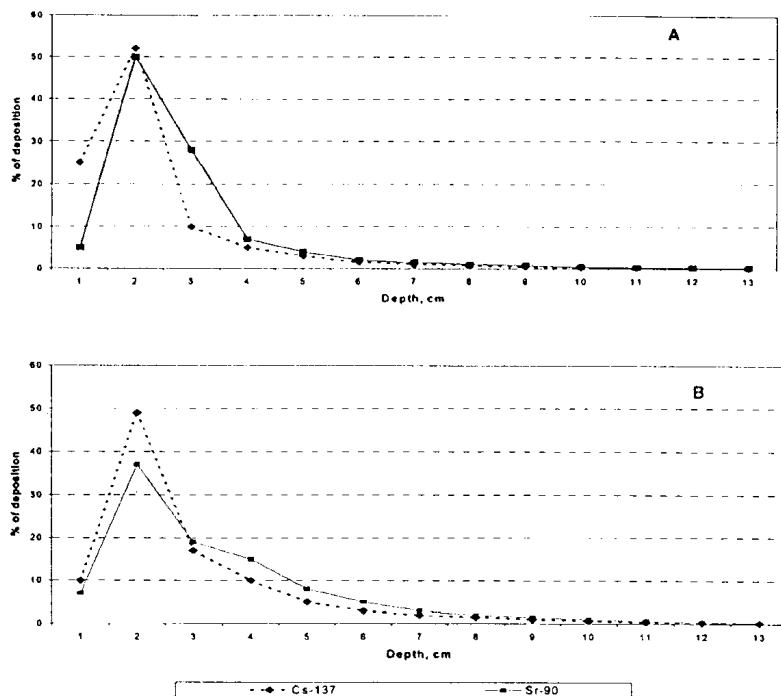

Fig. 4. Vertical distribution of ^{137}Cs and ^{90}Sr in (A) automorphic and (B) hydromorphic soil key plots 1 and 2 respectively.

This difference is apparently caused by different capacity of the soils for radionuclide sorption from the liquid phase. The radionuclide sorption from the intrasoil flow as a rule decreases with depth.

Thus, the investigated automorphic sandy soils serve as an effective filter for ^{137}Cs : even under extreme deposition (more than 20 MBq/m^2), the concentration of ^{137}Cs in the lysimetric water at the 30-cm depth does not exceed the maximum permissible level for drinking water (8 Bq/l). Hydromorphic peat soils are least effective in this respect and let a large proportion of ^{137}Cs to the deep soil layers and ground water.

TABLE 14. ^{137}Cs transport by infiltration through different soil layers (average-annual for 1998)

Plot / Deposition (kBq/m^2)	Depth	Percolated water (m^2/y)	Concentration (Bq/l)	Sorption in the layer (%) [*]	Output $\text{Bq/m}^2 \cdot \text{y}^{-1}$	Output (% of total in the layer)
1 / 139 kBq/m^2	0–5	197.3	0.40 ± 0.08	--	78.0	0.11
	0–10	144.5	0.33 ± 0.07	17.5	47.5	0.045
	0–20	131.2	no data	no data	no data	no data
2 / 146 kBq/m^2	0–5	188.8	1.08 ± 0.18	--	185	0.38
	0–10	183.3	0.98 ± 0.49	9.2	155	0.14
	0–20	144.1	0.85 ± 0.12	21.2	155	0.11
3/ 1902 kBq/m^2	0–5	192.3	18.5 ± 2.98	--	3557	0.37
	0–10	108.5	17.8 ± 2.82	3.7	1931	0.11
	0–20	88.9	5.30 ± 0.57	71.3	497	0.026
4/ 21383 kBq/m^2	0–5	232.4	187 ± 26.2	--	43458	0.18
	0–10	144.6	95.3 ± 12.8	49.1	13780	0.06
	0–20	139.3	12.3 ± 1.85	93.4	1713	0.008
	0–30	124.7	5.60 ± 0.77	97.1	698	0.003

* % of the concentration in the waters from layer 0–5 cm.

Annual flux and dynamics of ^{137}Cs in the lysimetric waters

In general, a very small proportion of ^{137}Cs is transported down the soil profile by the intrasoil flow as compared to the total deposition (Table 15). Average annual flux of this radionuclide with intrasoil flow from the layer 0–5 cm varies within the limits 0.11–0.37% of its total inventory in this layer. The corresponding outflux from the layer 0–20(30) cm varies from 0.08 to 0.11% depending on soil type. The highest flux is characteristic for the hydromorphic soil (plot 2), which is due to the combined effect of intensive leaching in the forest litter, low sorption capacity, and intensive annual water flux through the hydromorphic soil.

Long term dynamics of ^{137}Cs concentration in the lysimetric water does not exhibit any pronounced trend (Table 16). Some increase in cesium concentration from layer 0–20 cm is characteristic for podzolic sandy soil (plot 3) and hydromorphic peat soil (plot 2). In the first case, the increase may be due to faster redistribution of the radionuclides down the soil profile [Shcheglov, 1996], their low absorption in podzolic horizon/, and periodical flashing regime in the underlying illuvial (B) horizon.

TABLE 15. Long term dynamics of ^{137}Cs in the lysimetrical waters (Bq/l).

Plot	Depth (cm)	Year				
		1989	1990	1991	1993	1998
1	0–5	1.03	0.84	0.50	0.58	0.40
	0–20	0.42	0.40	0.23	0.35	0.28
2	0–5	0.27	0.84	1.16	0.85	1.08
	0–20	0.31	0.45	1.05	0.81	0.98
3	0–5	16.3	8.25	11.40	29.5	18.5
	0–20	1.63	1.37	2.98	2.55	5.3
4	0–5	132	285	116	244	187
	0–20	9.67	4.85	5.05	2.26	5.3

In hydromorphic peat soils, the observed high concentration of ^{137}Cs in the water from layer 0–20 cm is likely to be due to enrichment of this territory (accumulative landscape) with the radionuclide coming from neighboring territory on the background of its low sorption in the organic (peat) layer [15].

Preliminary estimation of ^{137}Cs influx to upper aquifers

The above discussed suggest that hydromorphic landscapes are characterized by the most significant potential influx of the radionuclides into the local aquifers. Assuming that (1) radionuclide concentration in the intrasoil flow decreases by 10% per each 10 cm of the profile of a hydromorphic soil and (2) water table is at the depth of 1–2 m, the annual influx of caesium to this aquifer may be about 0.03–0.05% of total deposition. Absolute rate of ^{137}Cs migration to the ground waters in this case is up to $75 \text{ MBq/km}^2 \cdot \text{y}^{-1}$ even for the least contaminated territories (plot 2, 0.15 MBq/km^2). This conclusion is confirmed by the results of model calculation as well.

It must be emphasized that ^{137}Cs is reported to be the least mobile of all radionuclides but ^{144}Ce . By contrast, ^{90}Sr in the most mobile radionuclide in intrasoil flow. (Table 16). The deposition of this radionuclide in the investigated region varies from 50 to 70% of ^{137}Cs deposition, while the migration ability of ^{90}Sr in the water is believed to be about 7–10 times higher than ^{137}Cs [Klyashtorin, 1994]. With this all, it may be assumed that at least 0.1% of total deposition of both ^{137}Cs and ^{90}Sr comes annually to the ground water in hydromorphic landscapes, which for the plot 2 may sum up to 250 MBq/km^2 . This preliminary estimation will be clarified in the course of our future studies.

5. Radionuclide Redistribution in the System of Geochemically Joint Landscapes

According to current biogeochemical concepts, the landscape-geochemical features of any territory have a significant effect on the processes of primary and secondary distribution of chemical elements in the territory [Perel'man, 1975].

TABLE 16. Comparative outflow of radionuclides with infiltration water from different soil layers (1997)

Layer (cm)	OUTFLOW (% from the layer, % of total deposition)				
	¹⁴⁴ Ce	¹⁰⁶ Ru	¹³⁷ Cs	⁹⁰ Sr	²³⁸⁺²⁴⁰ Pu
Automorphic landscape, pine forest (key site 3)					
0–5	0.15	0.52	0.073	0.92	0.073
0–10	0.06	0.67	0.015	0.57	0.091
0–20	0.01	0.14	0.005	0.17	0.068
Automorphic landscape, mixed forest (key site 4)					
0–5	0.078	0.095	0.087	0.11	0.076
0–10	0.003	0.031	0.004	0.03	0.005
0–20	0.001	0.019	0.002	0.03	0.003
0–30	no data	0.014	0.003	0.02	0.001

Eluvial (normally automorphic) landscapes tend to lose elements and nutrient, and accumulative (normally hydromorphic) landscapes tend to accumulate them. At the same time, the rate of the large scale element distribution at the landscape scale is very low. It was shown that 10 years after the atmospheric tests, the deposition of "weapon" ⁹⁰Sr in the automorphic forest landscapes decreased by a factor of two and increased by the same factor in the hydromorphic areas [Tyuryukanova, 1973].

High deposition in the exclusion zone make the problem of large scale redistribution of radionuclides of high practical significance especially in terms of their possible concentration in the accumulative landscapes. Some authors suggest that such vertical and lateral migration is, though weakly manifested, is already observable [Shestopalov, 1986]. Our direct field studies, however, revealed no significant changes in the deposition of ¹³⁷Cs and ⁹⁰Sr for 10 years since 1986 (Table 17).

TABLE 17. Long term dynamics of ¹³⁷Cs и ⁹⁰Sr deposition in the soils of geochemically joint landscapes (30-km exclusion zone, kBq/m²)

Radio-nuclide	Year										
	1986	1987	1988	1989	1990	1991	1992	1993	1994	1995	1999
Eluvial landscape (Key site D-1)											
¹³⁷ Cs	242.3	209.4	192	180.9	172.4	165.8	160.1	156.1	152.4	148.7	140.3
⁹⁰ Sr	nd	154.3	nd	66.6	40.7	nd	31.3	nd	nd	nd	nd
Accumulative landscape (Key site D-3)											
¹³⁷ Cs	237.2	209.4	194.6	185	177.6	172.1	167.2	163.2	159.8	156.9	160.4
⁹⁰ Sr	nd	168.4	nd	84	51.8	nd	53.8	57.8	nd	nd	nd

By 1996, the difference (σ) between ^{137}Cs deposition in the soils of adjacent, geochemically joint landscapes varied within the range of statistical variability.

^{90}Sr redistribution in the system of geochemically joint landscapes is more pronounced than ^{137}Cs , though less manifested compared to “weapon” strontium and also close to the statistical error [Tyuryukanova, 1982]. The correctness of the opinion in favor of more intensive redistribution of ^{90}Sr is confirmed by the data on its migration to the river network in the exclusion zone. The annual rate estimates to 0.65% for ^{90}Sr and 0.1–0.2% for ^{137}Cs [Shcheglov, 1996^b].

More correct information on geochemical redistribution of ^{137}Cs at the landscape scale can be obtained taking into account its inventory in the vegetation as well as soil deposition. In this case, the differences between decay-corrected deposition in the adjacent, geochemically joint eluvial and accumulative landscapes estimate to 40 kBq/m² or 20% per 10 years. Assuming the same initial deposition in the investigated eluvial and accumulative areas and taking into account statistical error, the estimated rate of the annual inter-landscape redistribution of ^{137}Cs is about 1% (conservative estimation).

The future differences between the eluvial and accumulative landscapes by ^{90}Sr deposition may be estimated on the basis of present differences in the content of stable strontium in the landscapes. The inventory of stable strontium in the accumulative landscapes is higher compared to adjacent eluvial landscapes by a factor of 2–3. The final differences in ^{90}Sr content will unlikely exceed this value, since accumulative landscapes slowly lose elements to the river network [Shcheglov, 1999].

The rate of radionuclide redistribution within the elementary landscapes at the scale of micro-topography (meters at the horizontal scale and centimeters at the vertical scale). The radionuclide content in the dish-like depressions, local hollows, etc., are by 5–30% higher than in the convex elements of local topography as soon as 5 years after the accident (Table 18). The difference is most manifested for ^{106}Ru and ^{137}Cs , which are known to be the most mobile of all gamma-emitting radionuclides. The share of ^{106}Ru in the radionuclide composition in the depressions increased by a factor of 1.5 compared to the adjacent plane areas.

The radionuclide redistribution within the landscape is even more manifested at the scale of meso-topography (tens of meters at the horizontal scale and meters at the vertical scale). With the slopes of 15° and steeper, and height difference of 2–3 m, the σ values may reach 50–100% (up to % for ^{106}Ru) (Table 19). Maximum radionuclide accumulation takes place in the marginal areas of the concave topographical elements, e.g., slope basement.

In general, the most manifested geochemical barriers of various scales are attributed to the marginal areas of the accumulative zones. This phenomenon is in agreement with the data on the large scale distribution of stable elements and nutrient in different landscapes [Borisenko, 1989, Perel'man, 1975]. Some authors believe, however, that lower radionuclide content in the central areas of the depressions is due to more intensive loss for infiltration [Bolyukh, 1996, Shestopalov, 1996]. In our opinion this may be true for the case of dish-like depressions of tens to hundreds square meters in area rather than large scale accumulative landscapes. Thus, the present differences in the radionuclide content at the scale of micro- and meso-topography are determined by the migration processes rather than spatial heterogeneity of the initial fallout.

TABLE 18. Deposition and radionuclide composition of the adjacent, geochemically joint micro-topographical forms (30-km exclusion zone, 1991, means of n=15) [Shcheglov, 1999,]

Micro-topographical forms	Radionuclides				Total
	¹⁴⁴ Ce	¹³⁴ Cs	¹³⁷ Cs	¹⁰⁶ Ru	
	Deposition kBq/m ²				
Micro-convexity	17.02	15.54	157.99	12.95	203.5
Micro-depression	17.76	19.98	191.66	19.24	248.64
	Relative units				
Micro-convexity	100	100	100	100	100
Micro-depression	104.2	122.2	117.6	132.7	118.3
	Radionuclide composition, %				
Micro-convexity	8.4	7.7	77.6	6.3	100
Micro-depression	7.2	8	77	7.8	100

TABLE 19. Deposition and radionuclide composition of the adjacent, geochemically joint meso-topographical forms ("near zone", 1991, means of n=15)

Micro-topographical forms	Radionuclides					Total
	¹⁴⁴ Ce	¹³⁴ Cs	¹³⁷ Cs	¹⁰⁶ Ru	⁹⁰ Sr	
	Deposition kBq/m ²					
The top of a sand ridge	0.45	0.3	3.33	0.24	1.12	5.44
The slope of a sand ridge	0.49	0.34	3.32	0.38	1.55	6.08
The slope basement	0.63	0.53	5.41	0.38	1.87	8.82
Bottom of the adjacent hollow	0.6	0.41	4.49	0.57	1.28	7.35
	Relative units					
The top of a sand ridge	100	100	100	100	100	100
Slope of a sand ridge	108.9	113.3	99.7	158.3	138.4	111.8
The slope basement	140	176.7	162.5	100	167	162.1
Bottom of the adjacent hollow	133.3	136.7	134.8	237.5	114.3	135.1
	Radionuclide composition, %					
The top of a sand ridge	8.3	5.5	61.2	4.4	20.6	100
Slope of a sand ridge	8.1	5.6	54.6	6.2	25.5	100
The slope basement	7.1	6	61.3	4.4	21.2	100
Bottom of the adjacent hollow	8.2	5.6	61.1	7.7	17.4	100

Moreover, many authors suppose that the dish-like depressions were initially less contaminated than the adjacent convex topographical elements. The initial difference has been smoothed in the course of time and radionuclide inventory in the depressions increased drastically 3-4 years after the fallout. The initial increase within the depressions was followed by somewhat decrease in deposition in the very central area of each depression [Anokhin, 1989].

Redistribution of Chernobyl-derived ^{90}Sr in the meso-topography is low-manifested compared to “weapon” ^{90}Sr [Tyuryukanova, 1976]. This may be explained by (i) specifics of Chernobyl fallout (see above) and (ii) coarse texture of the soils in the exclusion zone, which provide more opportunities for ^{137}Cs and ^{106}Ru migration. The central areas of local dish-like depressions in sandy soils are likely to serve as conduction zones for ^{90}Sr rather than geochemical barriers [Shestopalov, 1996].

Thus, the large scale redistribution of radionuclides in the system of geochemically joint landscapes is least manifested for ^{137}Cs (currently $< 1\%$ per year). This process is better manifested for ^{90}Sr , although its intensity still does not exceed the rate of physical decay. The intensity of radionuclide redistribution within the elementary landscapes at the scale of meso- and micro-topography is more evident and reaches 10% per year.

6. Conceptual model and parameters of biogeochemical migration of ^{137}Cs in forest landscapes

The model consists of two main compartments **soil** and **biota**, which are subdivided into more specific sub-compartments (Fig. 5).

The contribution of the unit to total contamination of a biogeocenosis changes in the course of time. It will be remembered that about 90% of total deposition was initially retained in the overstorey (arboreal vegetation), and (at least formally) belonged to the **biota** compartment in the first months after the accident. Currently of 6.5 to 43.9% of total deposition in forest ecosystems is accumulated in the biota depending on ecosystem and landscape conditions. Taking into account that presently these values are related to the radionuclides involved to the biological cycle, the role of biota in radionuclide retention at least the same high as it was in 1986.

At the same time, ^{137}Cs is redistributed among the biota components: the contribution of the overstorey decreases, in spite of its considerable phytomass, while the contribution of understorey (especially moss cover) and soil mycobiota increases. Moss cover may accumulate of 0.08 to 5.85% of total deposition.

It is comparable with (in pure pine cenoses) or even exceeds (in bog forest) the contribution of the overstorey. The corresponding variation range suggested by other authors is even wider: from 1 to 12% of total deposition [Kulikov, 199, Pushkarev, 1996]. The highest contribution to the radionuclide inventory in the **biota** compartment (2.7 – 23.5%) is made by mycobiota. Upper limit of this range seems to be unbelievably high and deserves to be discussed in more detail. In spite of soil fungi are known to be effective concentrators of radionuclides, their contribution to the radionuclide pattern in the contaminated forests was neglected because of presumed low biomass of fungi (based apparently on the estimations of the above ground biomass) [Zhdanova, 1995].

The suggested values are based on estimation of total fungi biomass (including underground mycelium) and experimental data on ^{137}Cs accumulation in mycelium (10 – 63% of deposition) [Guillitte, 1994, Olsen, 1990]. Herbs and shrubs make the lowest contribution of all biota components to ^{137}Cs accumulation (maximum 1.7%).

Thus, the biota components may be ranked by their capacity for cesium accumulation as follows: mycobiota $>$ mosses $>$ overstorey $>$ herbaceous vegetation and shrubs.

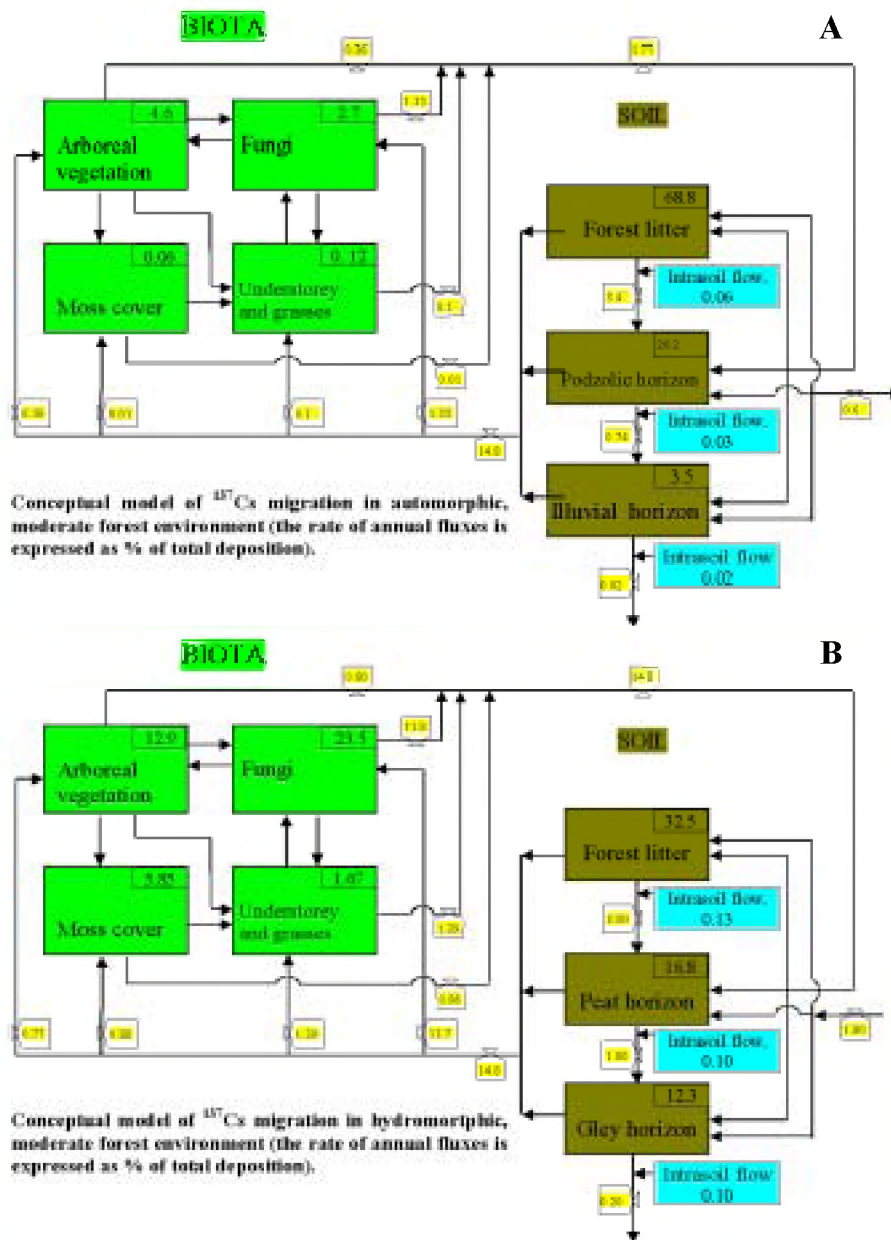

Conceptual model of ^{137}Cs migration in automorphic, moderate forest environment (the rate of annual fluxes is expressed as % of total deposition).

Conceptual model of ^{137}Cs migration in hydromorphic, moderate forest environment (the rate of annual fluxes is expressed as % of total deposition).

Fig. 5. Conceptual models of ^{137}Cs migration in forest environments in autormorphic (A) and hydromorphic (B) areas (30-km exclusion zone, 1998).

The contribution of mycobiota depends on both landscape and ecosystem factors and increase in the range: pine forests > hydromorphic areas > automorphic areas. Mycobiota is therefore the most probable factor of radiocesium retention by forest litter.

Throughfall and stem flow make insignificant contribution to ^{137}Cs pattern in the ecosystem as a whole (both constitute about 0.05% of total deposition per year), but may be of importance in terms of radionuclide fluxes. E.g., the above value is comparable with annual rate of ^{137}Cs infiltration from the forest litter and (in the “remote zone”) annual root uptake to the overstorey.

In the **soil** compartment, the main flux of ^{137}Cs (1.6–3.4% per year) occurs from forest litter to the topmost mineral layer. Down the soil profile, the radionuclide flux becomes as small as $n \cdot 0.1 - n \cdot 0.01\%$ of total deposition, i.e., almost all radionuclides which left the forest litter are accumulated in the upper few centimeters of mineral soil. No more than hundredth of a percent of the total deposition leave annually the soil layer of 0.5 m in thickness. The only exclusion is hydromorphic soils of accumulative landscapes where the infiltration flow is most manifested and almost stable down the soil profile. These soils exhibit maximum relative loss of radiocesium from the profile, and in these environments the radionuclide influx to the ground water is most probable. It means that the role of the so-called “fast component” in ^{137}Cs vertical migration is much more manifested in the peat soils compared to soddy-podzolic soils [Spiridonov & Fesenko, 1996]. Comparison of actual radionuclide distribution down the soil profile with the infiltration rate suggests that the contribution of the infiltration to the radionuclide distribution in the soil is insignificant for upper 20–30 cm of the soil and of high importance for deeper layers.

In general, the rate of the radionuclide involvement to the biological cycle is comparable with their annual loss beyond the conventional soil boundaries. It means that the biological cycle is a powerful factor preventing radionuclide from migration to ground water. In accumulative landscapes, the contribution of biota to ^{137}Cs accumulation and migration through the ecosystem components (particularly its root uptake) increases almost tenfold. This is due to low capacity of organic, peat-bog soils for cesium irreversible absorption, high TF, and long term influx of ^{137}Cs from neighboring areas with lateral intrasoil flow and surface transport. Total annual increment of ^{137}Cs in the accumulative landscapes due to its large scale lateral migration normally does not exceed 1% per year.

7. Mathematical model

Our mathematical models have initially been developed to describe and forecast ^{137}Cs migration in the soil-plant system in the territories contaminated due to the Chernobyl accident [Mamikhin, 1995; Mamikhin, Kliashtorin, 1999]. The models were improved to describe radionuclide migration to deeper soil layers (up to 100 cm) and upper aquifers (soil water).

Model Description

The presented models are case-specific and describe migration of ^{137}Cs after a single fallout event of a highly dispersed ($< 10 \mu\text{m}$) particles, e.g., “Chernobyl” type of fallout). The models describe two-contrast ecosystem, both typical for East and North-East Eaurasian moderate forest environments: (1) Mixed oak-pine-birch forest on automorphic soddy-podzolic soil in eluvial landscape and (2) Alder forest on hydromorphic peat-gley podzolic soil. The models are of “point” type and do not consider spatial distribution or lateral migration of the radionuclides. Nevertheless they may be used as GIS elementary units to estimate transport of ^{137}Cs to ground water and surface water sources, i.e. may be applied for description spatial processes as well. General structure of the models is presented in Fig. 6.

Fig. 7 and 8 present a topological structure of the model sub-models describing the dynamics of ^{137}Cs content in various ecosystem components (both soil and phytocenosis). The compartments correspond to the radionuclide content in each component and the arrows identify main fluxes. The radioactive decay functions are not depicted in Fig. 7, but it presents in the model. The driving variable is the radionuclide flux from the atmosphere (fallout).

“Vegetation” sub-model

We have tried various approaches to model ^{137}Cs dynamics in the vegetation and found the most effective algorithm:

- (1) The radionuclide content in arboreal vegetation is sub-divided into two parts: (i) external (exposed to fallout) and (II) internal (covered) tree organs and components. The radionuclide dynamics in these parts is expedient to describe separately. Radionuclide content in the external organs depends on (i) their contamination by initial fallout and (ii) subsequent natural decontamination process. In contrast, internal organs are contaminated due to the root uptake or radionuclide redistribution within the plant. The "internal" contamination is determined by radionuclide uptake by the root systems only.
- (2) ^{137}Cs behaviour in the ecosystem obeys the same regularities as its stable carrier, potassium.
- (3) The radionuclide dynamics is considered to be agreed with the phytomass dynamics.

The “vegetation” sub-model includes the following state variables:

X_i - Inventory of organic matter in the vegetation (g/m², dry weight); K_i - Inventory of potassium in the vegetation (g/m², dry weight); ^{137}Cs content in the vegetation components (Bq/kg, dry weight): Z_i - internal, Y_i - external; E_i - total (average); Scd - ^{137}Cs inventory in the soil (Bq/m²); Cd - ^{137}Cs total deposition (Bq/m², soil + vegetation).

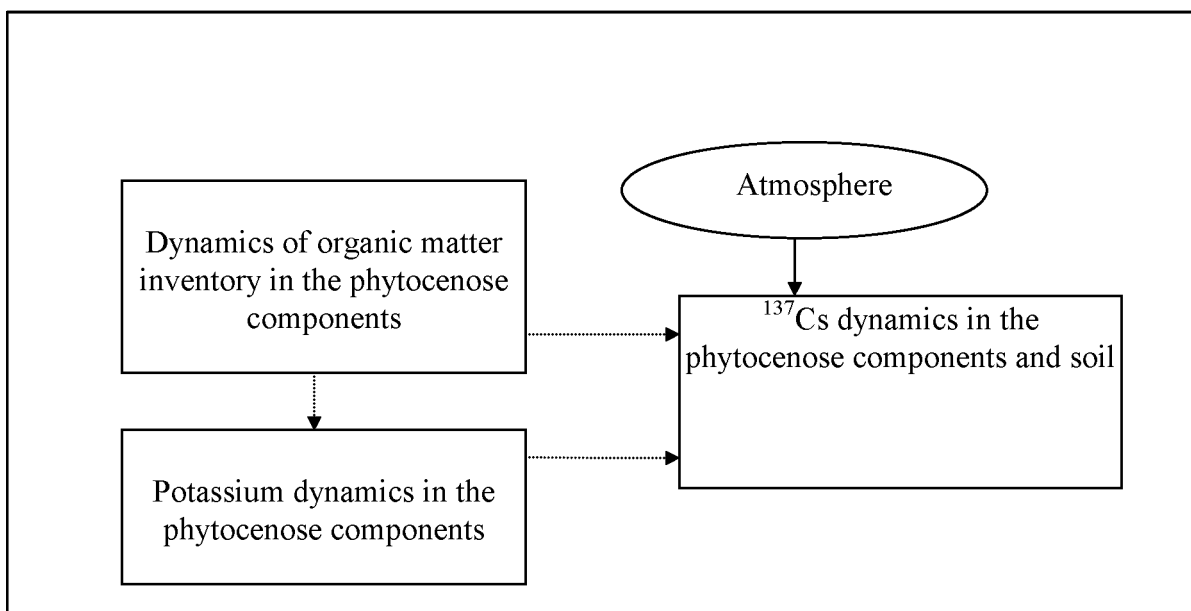

Fig. 6. General structure of the models.

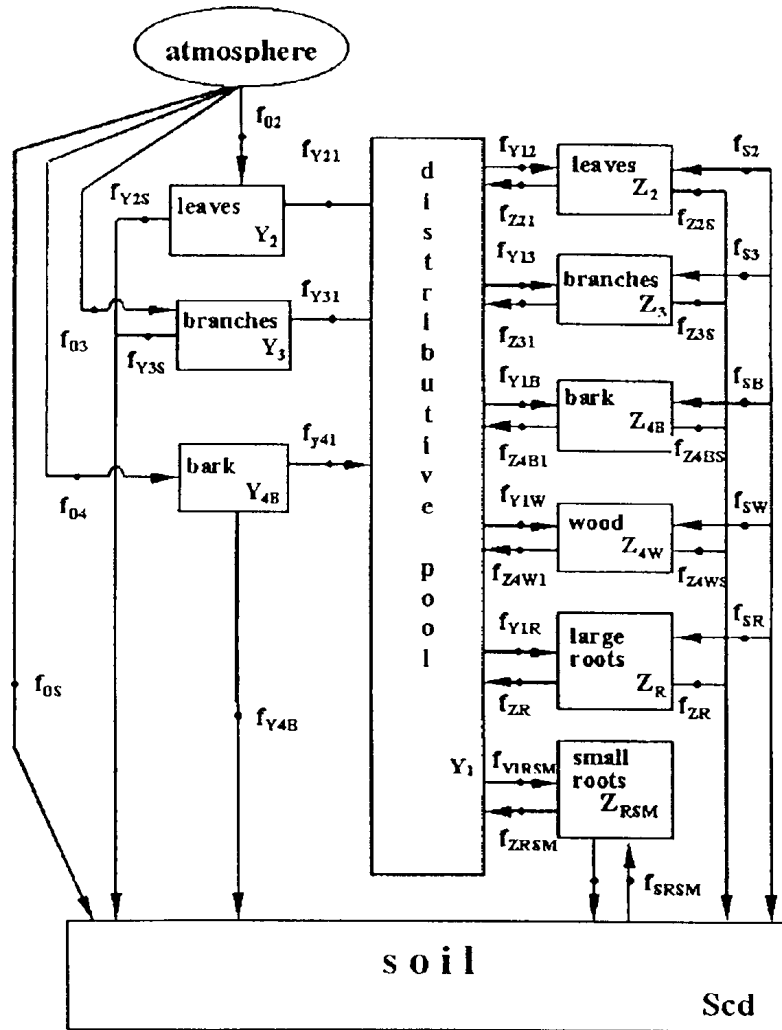

Fig. 7. Flow diagram of the "Vegetation" sub-model

Index i indicates the following organs and components: 1 - Distribution pool; 2- leaves (needles); 3 - branches; 4w - stem wood; 4b - stem bark; r - large roots; rsm - small roots.

Behaviour of ^{137}Cs is described by a system of differential equations as follows:

$$dY_1/dt = f_{Y21} + f_{Y31} + f_{Y41} + f_{Z21} + f_{Z31} + f_{Z4B1} + f_{Z4W1} + f_{ZR} + f_{ZRSM} - f_{Y12} - f_{Y13} - f_{Y1B} - f_{Y1W} - f_{Y1R} - f_{Y1RSM};$$

$$dY_2/dt = f_{02} - f_{Y21} - f_{Y2S} - f_{Y2D};$$

$$dY_3/dt = f_{03} - f_{Y31} - f_{Y3S} - f_{Y3D};$$

$$dY_4/dt = f_{04} - f_{Y4B1} - f_{Y4BS} - f_{Y4D};$$

$$dZ_2/dt = f_{Y12} + f_{S2} - f_{Z21} - f_{Z2S} - f_{Z2D};$$

$$dZ_3/dt = f_{Y13} + f_{S3} - f_{Z31} - f_{Z3S} - f_{Z3D};$$

$$dZ_{4B}/dt = f_{Y1B} + f_{SB} - f_{Z4B1} - f_{Z4BS} - f_{Z4BD};$$

$$dZ_{4W}/dt = f_{Y1W} + f_{SW} - f_{Z4W1} - f_{Z4WS} - f_{Z4WD};$$

$$dZ_R/dt = f_{Y1R} + f_{SR} - f_{ZR} - f_{ZRS} - f_{ZRD};$$

$$dZ_{RSM}/dt = f_{Y1RSM} + f_{SRSM} - f_{ZRS} - f_{ZRSMS} - f_{ZRSMD};$$

$$dScd/dt = f_{0S} + f_{Y2S} + f_{Y3S} + f_{Y4S} + f_{Z2S} + f_{Z3S} + f_{Z4BS} + f_{Z4WS} + f_{ZRS} + f_{ZRSMS} - f_{S2} - f_{S3} - f_{S4} - f_{SB} - f_{SW} - f_{SR} - f_{SRSM}.$$

Transfer functions.

External contamination:

- ^{137}Cs content by the above ground phytomass - $f_0 i$;
- Outflux from the vegetation due to litterfall - f_{Yi} ;
- Contribution of each component to the distribution pool - f_{Yi} ;
- Radioactive decay - f_{Yid} .
- Internal contamination:
 - Distribution of ^{137}Cs from each component to the distribution pool - f_{Zil}
 - Distribution of ^{137}Cs from the distribution pool to each component - f_{YIZi}
 - Distribution of ^{137}Cs from the soil to each component - f_{Si}
 - Return of the "incorporated" ^{137}Cs from the tree plants to the soil with litterfall - f_{iS}

"Soil" sub-model

The sub-model includes the following state variables:

P - ^{137}Cs content in the external components of vegetation.

S_{ao} - Total ^{137}Cs content in the forest litter (AoL + AoF + AoH);

$X(i)$ - Mobile component of ^{137}Cs in the mineral soil layers,

$Y(i)$ - Immobile component of ^{137}Cs , where $i = 1, \dots, n$ - is the number of soil layer (cm).

State variable R is the conventional distribution pool describing ^{137}Cs redistribution in the soil due to the root systems and fungi hypha. The sum of input fluxes to the pool is assumed to be equal to the sum of the output fluxes.

The "immobile" form of ^{137}Cs consists of the radionuclides irreversibly absorbed in the soil, incorporated to the fine clay particles, bound with insoluble organic compounds, exchangeable ^{137}Cs , and the radionuclides incorporated in the roots. All other forms are assumed to be "mobile".

The dynamics of the "soil" sub-model is expressed as follows:

$$dP/dt = f_{ap} + f_{sp} - f_{ps} - dp;$$

$$dS_{ao}/dt = f_{as} + f_{ps} - f(1) - ds;$$

$$dX(i)/dt = f(i) - f(i+1) - d1(i) - xy(i) + g(i) + rx(i) - xr(i);$$

$$dY(i)/dt = xy(i) - d2(i) - g(i) + df(i) - df(i+1);$$

$$dR/dt = xr(i) - rx(i) - dr;$$

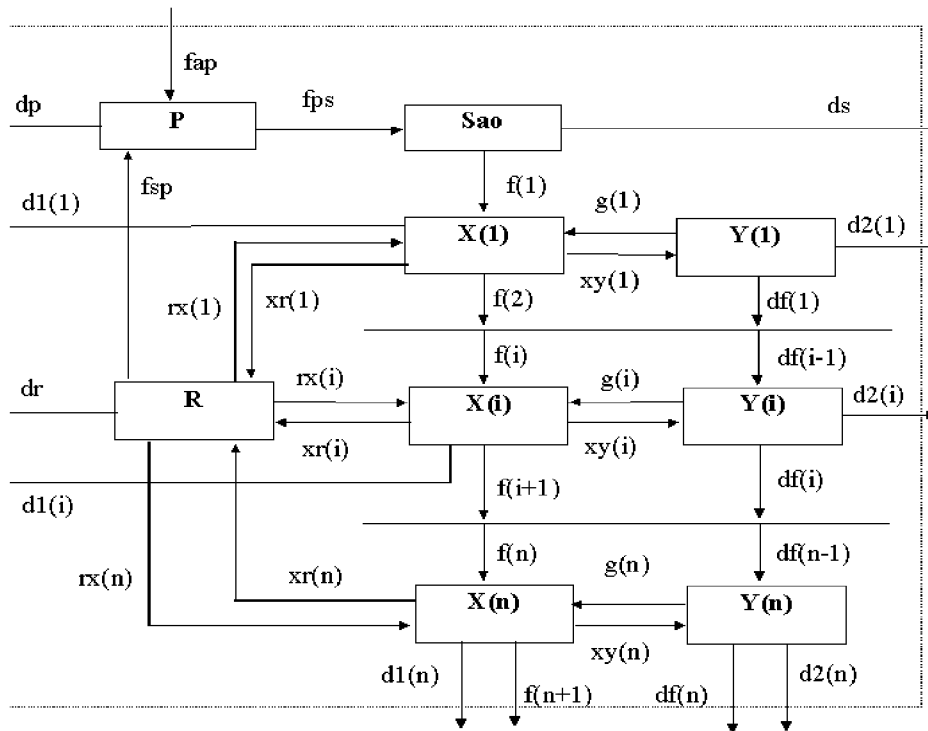

Fig. 8. Flow diagram of the "Soil" sub-model.

Transfer functions:

- ^{137}Cs coming to the above ground phytomass from the atmosphere - fap
- ^{137}Cs coming to the above ground phytomass from the soil - fsp
- ^{137}Cs coming to the forest litter as initial fallout and litterfall - fps
- Total release of ^{137}Cs from the forest litter to mineral layers - $f(1)$
- Downward transport of ^{137}Cs in the mineral soil layers due to infiltration of mobile forms and lessivage (migration of the radionuclides incorporated in the fine particles) - $f(i)$
- Downward transport of ^{137}Cs in the mineral layers due to diffusion - $df(i)$
- Immobilisation of mobile ^{137}Cs in each i soil layer due to reversible and irreversible absorption by soil organic and mineral components - $xy(i)$
- Mobilization of the immobile forms of ^{137}Cs due to desorption, ion exchange, and decomposition of organic matter and soil minerals, etc. - $g(i)$
- Radionuclide uptake by the plant roots and fungi hypha - $xr(i)$;
- Release of ^{137}Cs from alive and dead roots and mycelium - $rx(i)$
- Radioactive decay rate - di

Model advantages and shortcomings

Fieldwork in the contaminated areas is dangerous, expensive, and requires trained personnel. Obtaining quality data depends on spatial variability of the deposition and soil properties, and a range of other factors.

The main advantage of the presented model is that it may be applied as a useful tool to study radionuclide distribution among the ecosystem components and down the soil profile. Using the models makes it possible to forecast vertical radionuclide in the soil proceeding from very limited initial data: (1) deposition, and (2) type of landscape. The radionuclide profile in the soil may be expressed as absolute (kBq/m²) and relative (% of deposition) figures. Being very simple by structure, the suggested models are helpful to estimate the probability and relative extent of the contaminant coming to the ground water.

At the same time, the models have a range of shortcomings. (i). Radionuclide migration to the soil water was verified to the depth of 30 cm only, which reduce the reliability of the calculated values, especially in hydromorphic soils with a complex seasonal dynamics of the water table. (ii). The models do not take into account seasonal rainfall variation and soil moisture dynamics, which may be very influential on the “fast” radiocesium component in the soil. (iii). The root distribution in the soils is not taken into account. (iv). The “soil” and “vegetation” sub-models are poorly integrated, which results in regressive dynamics of ¹³⁷Cs content in the vegetation. These and some other features of the models limit their applicability and predictive significance by the environments similar to Ukrainian Poles'e.

Specific features of the latter (poor, sandy soils and high rainfall) enable us to omit the mechanical transport of soil and radionuclides by earthworm. In other soil types this factor may serve as a key process determining the radionuclide distribution down the soil profile [Shcheglov, 1999].

Simulation and forecasting of long term migration of ¹³⁷Cs in forest ecosystems

Taking into account the above mentioned limitations, we have calculated vertical distribution of the Chernobyl-derived radionuclides in the soil profile and migration to the ground water for the future 100 years (Fig.9). The calculations show that ¹³⁷Cs is replaced gradually from the contaminated overstorey to the soil. In the eluvial, automorphic landscape, it is expressed as almost monotonous exponential decrease of the radionuclide content in the “vegetation” sub-model. In the accumulative, hydromorphic landscape, the maximum of ¹³⁷Cs content in the vegetation fall on 7 years after the fallout. In the ensued years, the radionuclide content in the vegetation on hydromorphic soils also decreases, though slower than on the automorphic soils.

The calculations suggest that forest soils serve as an effective barrier for the radioactive fallout. According to the model calculations, less than 0.0001% of ¹³⁷Cs leave annually from the 100-cm soil layer and potentially able to enter the aquifers. On the other hand, the model calculations are likely to be true for upper 30–40-cm layers, but cannot explain the presence of significant amount of radionuclides in the soil layers deeper 50–70 cm. Detectable amount of Chernobyl-derived cesium in the deep aquifers reported by other participants (e.g., Gudzenko) suggest on possible other mechanisms determining radionuclide migration in the water phase. This is partly confirmed by our lysimetrical data. It may be due to the limitations of the model (see above) and fast local migration in the “conduction” zone of local depressions [Shectopalov,].

Suggested improvements to the model

Additional laboratory studies are necessary to conduct to clarify the model parameters and individual contribution of infiltration and diffusion to ¹³⁷Cs migration depending on soil

moisture regime. The model structure also needs improvement. Current progress in computing makes it possible to describe the models in much more detail taking into account seasonal dynamics of biological processes, weather conditions, and root distribution in the soil. It is also necessary to integrate the “vegetation” and “soil” sub-models for adequate modelling of cesium availability for plants.

To refine the prognosis, it would be expedient to develop the similar model for the intermediate (semihydromorphic) soils. At the second stage, the model will be adapted for larger fallout particles ($> 10 \mu\text{m}$).

Further optimisation of the model depends on the development of a sub-model simulating the dynamics of the organic matter and potassium in the ecosystem components and further quantitative studies on the model parameters in various soil types.

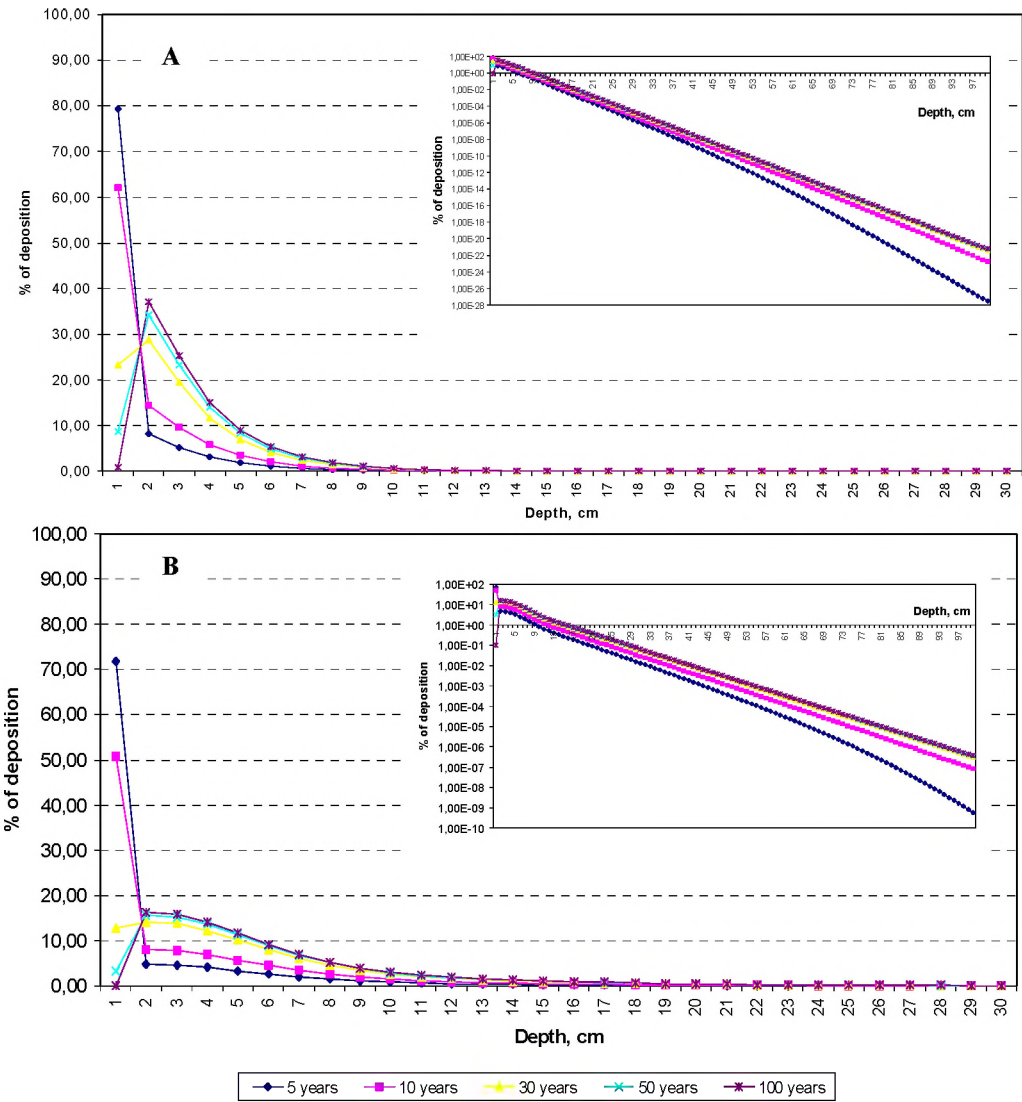

Fig. 9. Simulated vertical distribution of ^{137}Cs in the soil profile for various time periods after a single fallout event to the depth of 30 cm (normal scale) and 100 cm (logarithmic scale).

CONCLUSIONS

(1) Average content of the Chernobyl-derived radionuclides in the soil liquors is low (0.01–2%). Maximum sorption of plutonium and americium takes place in the sub-horizons of forest litter A0f and A0h. Sorption of ^{90}Sr and ^{137}Cs is maximal in the A0h and A0/A1 horizons.

Most proportion of the radionuclides (60 to 98%) in the liquid soil phase is associated with soluble organic matter of high (^{90}Sr) and medium (^{137}Cs , $^{239-240}\text{Pu}$, and ^{241}Am) molecular weight. These radionuclide-organic compounds are known to be very mobile and available for plants. The migration ability of the radionuclides is inversely proportional to the molecular masses of the radionuclide-organic associates, and decreases in the range ^{90}Sr , ^{137}Cs , $^{239-240}\text{Pu}$ (^{241}Am).

(2) Forest biota is one of the key factors affecting the migration rates of ^{90}Sr and ^{137}Cs , and their possible transfer to ground water. Annual rates of the radionuclide uptake and return to the soil have a considerable effect on the radionuclide migration from the root-abundant soil layer to the ground water. The latter depends on the ecosystem and landscape features. A specific problem is migration and accumulation of plutonium isotopes. The effect of soil absorbing complex and biological cycling on their migration is not as manifested as for ^{137}Cs and ^{90}Sr , and relative influx of plutonium to the ground water is expected to be more intensive compared to other radionuclides.

(3) The most significant potential influx of the radionuclides into the local aquifers takes place in hydromorphic area. A probable annual influx of radiocaesium to the ground water is estimated as 0.03–0.05% of total deposition. The deposition of radiostrontium in the 30-km exclusion zone varies from 50 to 70% of ^{137}Cs deposition, while the migration ability of ^{90}Sr in the water is believed to be about 7–10 times higher than ^{137}Cs . It may be assumed that at least 0.1% of total deposition of ^{137}Cs and ^{90}Sr in the hydromorphic areas comes annually to the ground water.

(4) In the automorphic areas, the average rate of total annual replacement of the radionuclides from forest litter to the mineral soil layers in Ukrainian Poles'e is about 1.9–3.7%. The corresponding figure for hydromorphic forest environments is about 7% for the entire contaminated territory. Unlike forest litters, the radionuclide content in mineral soil horizons increases monotonously with time. Annual increment of ^{137}Cs in the 5-cm mineral soil layer is about 4% in hydromorphic area and 3% in automorphic area. The corresponding rates for the 5–10-cm layer are 1 and 0.5%, respectively. Both ^{90}Sr and ^{137}Cs are rather similarly distributed down the profile of the investigated forest soils on fluvioglacial sands. With other conditions being equal, higher intensity of ^{90}Sr migration is characteristic for pine forests in hydromorphic areas.

(5) Current annual involvement of ^{137}Cs and ^{90}Sr into the biological cycle is much higher than their outflux from the biogeocenosis (both vertical and lateral). The rate of involvement is much higher in accumulative landscapes compared to eluvial landscapes. The large scale lateral redistribution of the radionuclides in the system of adjacent, geochemically joint landscapes does not exceed 1% per year for ^{137}Cs , and is likely to be somewhat higher for ^{90}Sr . This process is better manifested for ^{90}Sr , although its intensity still does not exceed the rate of physical decay. The intensity of radionuclide redistribution at the scale of meso- and micro-topography (meters and tens of meters) may reach 10% per year.

PUBLICATIONS

The data and materials obtained for the last 3 years in the frame of this CRP were presented at several national meetings and included into the monograph: Shcheglov A.I., et al., "Biogeochemical Migration of Technogenic Radionuclides in Boreal Forest Ecosystems" Moscow: NAUKA, (is expected to be issued in April 2001). A copy of the book will be sent to IAEA immediately after its publication.

REFERENCES

- [1] AGAPKINA G.I, KRACK W., et al., Association of Chernobyl-derived (1995) $^{239+240}\text{Pu}$, ^{90}Sr , and ^{137}Cs with organic matter in the soil solution. *J. Environ. Radioactivity*, vol. 29, no. 3, pp. 257–269.
- [2] AGAPKINA G.I., TIKHOMIROV, F.A., AND SHCHEGLOV A.I. Dynamics and chemical forms of radionuclide compounds in the liquid phase of a forest soil at the Chernobyl accident zone. *Ekologiya*, 1994, no. 1, pp. 21–28.
- [3] AGAPKINA, G.I., TIKHOMIROV, F.A., SHCHEGLOV, A.I. Dynamics and organic forms of radionuclides in the liquid phase of gray forest soils in the exclusion zone of ChNPP. *Ekologiya (Ecology)* 1994. no. 1, pp. 21–28.
- [4] ALEXAKHIN, R.M. AND NARYSHKIN M.A., *Migratsiya radionuklidov v lesnykh biogeotsenozakh* (Radionuclide Migration in Forest Biogeocenoses), Moscow: Nauka, 1977.
- [5] ANOKHIN, A.B., LOMAKINA, N.V., Landscape and Geochemical Studies of the Technogenic Radionuclide Migration, *The All-Union Conference "Principles and Methods of Landscape-Geochemical Studies of Radionuclide Migration"* (Suzdal', November, 1989), Moscow, 1989, p.18.
- [6] BARBER, S.A. Biological availability of soil nutrients in the soil, Moscow, 1988.
- [7] BASILEVICH, N.I., TITLYANOVA, A.A., SMIRNOV, V.V., RODIN, L.E., NECHAEVA, T.N., LEVIN, F.I. *Methods for studies of biological cycles in different natural zones*, Moscow: Mysl, 1978.
- [8] BOLYUKH, V.A., Vertical Distribution of ^{137}Cs in Forest Ecosystems of Kiev Poles'e, *The 5th Conference "Liquidation of the Chernobyl Accident Consequences: the Results of 10-year Work"*, Zelenyi Mys, 1996, p. 262.
- [9] BORISENKO, E.N., SAMSONOV, A.E., Specifics of the Radionuclide Migration in the Prisma-river Floodplain (Smolensk NPP Region), *The All-Union Conference "Principles and Methods of Landscape-Geochemical Studies of Radionuclide Migration"* (Suzdal', November, 1989) Moscow, 1989, p. 22.
- [10] BUROVA, L.G. *Amazing World of Fungi*, Moscow, 1991.
- [11] CHEBOTINA M. YA. AND KULIKOV N.V., The Effect of Water-soluble Products of of Herbaceous Plants Decomposition on Radioisotope Absorption in Soils, *Ekologiya*, 1973, no. 1, pp. 102–103.
- [12] DIGHTON J. AND HERRILL A.D., Radiocaesium accumulation in the mycorrhizal fungi *Lactarius rufus* and *Inocybe logicystis* in upland Britain following the Chernobyl accident, *Trans. Brit. Mycol. Soc.* 1988, v. 91, no. 2. pp. 335–337
- [13] *Experimental studies of the landscapes of Prip'yat' National Reserve*, Minsk, 1986,
- [14] FILEP D., REDLY O., VARRO, T. Transport of clays in the soils of different porosity and moisture. *Pochvovedenie (Soil Science)*, 1986. no. 10. pp. 55–62.

- [15] Final Report for 1992–1995 activities of the EC coordinated ECP-5 International Project, Int. Atomic Energy Agency - *Doc. of Int. Union of Radioecologists*. 1995
- [16] GUILLITTE O., MELIN J., WALLBERG L. Biological pathways of radionuclides originating from the Chernobyl fallout in a boreal forest ecosystem, *Sci. Total Environ*, 1994, v. 157, pp. 207–215.
- [17] IL'IN V.P., Some Regularities of ^{137}Cs Geochemical Migration in various Landscapes of Ukrainian Poles'e, The All-Union Conference "Principles and Methods of Landscape-Geochemical Studies of Radionuclide Migration" (Suzdal', November, 1989), Moscow, 1989, p. 33.
- [18] IZRAEL, YU.A., PETROV, V.A., AVDONIN, S.I. et al., Radioactive Contamination of Natural Environments in the Accidentla Zne of the Chernobyl NPP, *Meteorologiya i Hidrologiya*, 1987, no. 2, pp. 5–18.
- [19] JUO A.S.R, BARBER S.A. Reaction of Sr with humic acid, *Soil Sci*, 1969, v. 108, pp 89–94.
- [20] JUO A.S.R., BARBER S. A. The retention of Strontium by soils as influenced by pH, organic matter and saturation cations, *Ibid.* 1970. v. 109, no. 3, pp. 143–147.
- [21] KARPACHEVSKII, L.O. *Les in Lesnye Pochvy* (Forest and Forest Soils), Moscow: Lesnaya Promyshlennost', 1981.
- [22] KLYASHTORIN A.L., TIKHOMIROV F.A. & SHCHEGLOV A.I. 1994. Lysimetrical study of radionuclides in the forests around the Chernobyl Nuclear Power Plant. *Journal of Environmental Radioactivity*, 24, 89–90
- [23] KLYASHTORIN, A.L., TIKHOMIROV, F.A. & SHCHEGLOV A.I. Lysimetrical study of radionuclides in the forests around the Chernobyl Nuclear Power Plant. *Journal of Environmental Radioactivity*, 1994, 24, 89–90
- [24] KRUGLOV, S.V., Physicochemical Aspects of Contamination of Agricultural Lands due to Radiation Accident and radionuclide Migration in the "Soil–Plant" System, *Doctoral dissertation*, Obninsk, 1997.
- [25] KULIKOV N.V., MOLCHANOVA, I.V., AND KARAVAEVA, E.N., *Radioekologiya pochevenno-rastitel'nogo pokrova* (Radioecology of Soil-Plant Cover), Sverdlovsk: Ural Branch of USSR Academy of Sciences, 1990
- [26] LOSHCHILOV, N.A., IVANOV, YU.A., KASHPAROV, V.A., LEVCHUK, S.E., BONDAR, P.F., DYRENKO, L.V. Vertical migration of different physico-chemical forms of Chernobyl-born radionuclides in the soils of Poles'e region. *Problems of Agricultural Radiology*, Kiev, 1991, pp. 36–44.
- [27] MAMIKHIN S.V. Mathematical model of Cs-137 vertical migration in a forest soil. *J. Environ. Radioactivity*, 1995, Vol.28, No.2, pp. 161–170.
- [28] MAMIKHIN S.V., KLYASHTORIN A.L. Mathematical model of ^{137}Cs dynamics in the deciduous forest. *J. Environ. Radioactivity*, 1999, Vol. 47, No.1, pp. 101–114
- [29] MAMIKHIN, S.V. & KLYASHTORIN, A.L. Mathematical model of ^{137}Cs dynamics in deciduous forest. *J. Environmental Radioactivity*, 1999, in press.
- [30] MIRCHIK, T.G. *Soil mycology*, Moscow, MSU, 1988.
- [31] MOLCHANOVA, I.V., MIKHAILOVSAKAYA, L.N., AND KARAVAEVA, E.N., Radionuclide Mobility in the Soil and Vegetative Cover of the Accidental Zone of ChNPP, *Ekologiyua*, 1991, no. 3, pp. 89–91.
- [32] MOLOZHANOVA, E.G., DRICH S.K., AND BURAVLEV, E.P., Radionuclide Distribution in Some Landscape of the 30-km exclusion zone, *The All-Union Conference "Principles and Methods of Landscape-Geochemical Studies of Radionuclide Migration"* (Suzdal', November, 1989), Moscow, 1989, p. 39.
- [33] MYAKUSHKO, V.K. *Pine forests of the plain territory of USSR*, Kiev, 1978.

- [34] OLSEN R.A., JONER E., AND BAKKEN L.R. Soil fungi and fate of radiocaesium in the soil ecosystem, *Transfer of radionuclides in natural and semi-natural environments*, L.; N. Y., 1990, pp. 657–663.
- [35] PAVLOTSKAYA, F.I., *Migratsiya radioaktivnykh produktov global'nykh vypadenii v pochvakh* (Migration of the Radioactive Components of Global Fallout in Soils), Moscow: Atomizdat, 1974
- [36] PEREL'MAN, A.I., *Geokhimiya Landshafta* (Landscape Geochemistry), Moscow: Vysshaya shkola, 1975.
- [37] PETRYAEV, SOKOLIK, G.A., IVANOVA, T.G., *et al.*, Chief Regularities of the Migration of Chernobyl-derived Radionuclides in the Landscapes of Southern Belarus', *The Fourth Conference "Geochemical Pathways of Technogenic Radionuclides in the Environment"*, Gomel, 1990, p. 28
- [38] PUSHKAREV, A.V., BOLUKH, V.A., AND PRIMAICHENKO, V.M., ¹³⁷Cs Distribution in the "Soil–Moss" Sytem in the Territory of Kiev Poles'e, Chernobyl-94: *The V International Conference "The Results of 8-year Activities on Liquidation of the Chernobyl Accident Consequences."*, Zelenyi Mys, 1996, V. 1, pp. 518–522.
- [39] ROZANOV, B.G., *Morphologiya pochv* (Soil Morphology), Moscow: Moscow State University, 1983.
- [40] SHCHEGLOV A.I, TIKHOMIROV F.A., TSVETNOVA O.B., KLYASHTORIN A.L. & MAMIKHIN S.V.^a (1996) Biogeochemistry of Chernobyl-Born Radionuclides in the Forest Ecosystems of European Part of Former Soviet Union. *Radiobiologia i radioekologiya* (Journal of Radiation Biology & Radioecology), 36-4: 469–477.
- [41] SHCHEGLOV A.I., TIKHOMIROV F.A., TSVETNOVA O.B. *et.al*^b, Biogeochemistry of Chernobyl-born radionuclides in Forest Ecosystems of European Part of CIS, *Radiats. biologiya, radioekologiya*, 1996. v. 36, issue 4, pp. 437–446.
- [42] SHCHEGLOV, A.I. *Biogeochemistry of Technogenic Radionuclides in Forest Ecosystems*, Moscow: Nauka, 1999, 262 pages (in Russian).
- [43] SHCHEGLOV, A.I., TIKHOMIROV, F.A., TSVETNOVA O.B., *et al.* Biogeochemistry of Chernobyl-derived radionuclides in the forest ecosystems of the European part of CIS. *Radiatsionnaya Biologiya i Radioekologiya (Radiation biology and Radioecology)*, 1996. Vol. 36, no.4. p.469
- [44] SHESTOPALOV V.M., BUBLYAS' V.P., GUDZENKO V.V. *et. al.* Study of the Fast Vertical Migration of Radionuclide in Geological Environments, *Chernobyl-94: The IV International Conference "The Results of 8-year Activities on Liquidation of the Chernobyl Accident Consequences."*, Zelenyi Mys, 1996, v. 1, pp. 110–119.
- [45] SPIRIDONOV, S.I. AND FESENKO, S.V. Mathematical Modeling of ¹³⁷Cs Fate in Soils, *The II Radioecological Symposium, Obninsk*, 1996. pp. 140–142.
- [46] SPIRIDONOV, S.I. AND FESENKO, S.V. Mathematical Modeling of ¹³⁷Cs Fate in Soils, *The II Radioecological Symposium, Obninsk*, 1996. pp. 140–142.
- [47] The Behavior of radionuclides in natural and semi-natural environments. Final report for the period of 1991–1995, *International Union of Radioecologists (EUR-IUR) 16531 EN*, Brussels, 1996, 148 pages.
- [48] TIKHOMIROV F.A., SHCHEGLOV A.I., TSVETNOVA O.B., AND KLYASHTORIN A.L. Geochemical Migration of Radionuclides in Forest Ecosystems Contaminated due to the Chernobyl Accident, *Pochvovedenie*, 1990. no. 10. pp. 41–50.
- [49] TSVETNOVA, O.B., SHCHEGLOV, A.I. Accumulation of ¹³⁷Cs by higher fungi and their role in biogeochemical migration of the radionuclide in forest ecosystems. *Vestnik MGU (MSU Herald)*, no. 17, *Soil Science*, 1996, no. 4b pp. 59–69.
- [50] SVETNOVA, O.B., SHCHEGLOV, A.I., KLYASHTORIN, A.L. Transport of plutonium isotopes with intrasoil infiltration flow in forest landscapes of Ukrainian

- Poles'e. *Proceedings of the 1st All-Russian conference "Lysimetrical Studies of Soils"*. Moscow, MSU, 1998. pp. 250–253.
- [51] TSVETNOVA O.B., AND SHCHEGLOV A.I. Accumulation of ^{137}Cs by Higher Fungi and their Role in the Biogeochemical Migration of the Radionuclide in Forest Biogeocenoses, *Vestn. MGU, Ser. 17. Pochvovedenie*, 1996, no 4. pp. 59–69.
- [52] TYURYUKANOVA E.B. Soil-Geochemical Aspects of Biosphere Contamination by Radionuclides (by the Example of Sr-90), *Doctoral Thesis*, Moscow, 1982.
- [53] TYURYUKANOVA E.B., BELYAEVA L.I., LEVKINA N.I., AND EMEL'YANOV V.V. *Landshaftno-geokhimicheskie aspekty povedeniya Sr-90 v lesnykh i poimennykh biogeotsenozakh poles'ya* (Landscape-Geochemical Aspects of Sr-90 Fate in the Floodplain Biogeocenoses of Poles'e), Moscow: USSR State Committee for Use of Nuclear Energy, 1973
- [54] TYURYUKANOVA E.B., *Ekologiya strontsiya-90 v pochvakh* (Soil Ecology of Strontium-90) Moscow: Atomizdat, 1976.
- [55] YOSHIDA S. AND MURAMATSU Y., Accumulation of radiocaesium in basidiomycetes collected from Japanese forests, *Sci. Total Environ*, 1994. v. 157. pp. 197–205 .
- [56] ZHDANOVA, N.N., ZAKHARCHENKO, V.A., VASILEVSKAYA, A.I., *et. al.*, The contribution of Fungi Biomass to the Radionuclide Transformation in Forest Litter, Published Report of Ukrainian Institute of Microbiology and Virusology, Ukrainian Academy of Medical Sciences, Kiev, 1995.

THE PECULIARITIES OF RADIOCESIUM MIGRATION IN THE NEMUNAS-NERIS WATER SYSTEM (LITHUANIA)

V. LUJANAS, N. TARASYUK, N. SPIRKAUSKAITE
Institute of Physics, Vilnius, Lithuania

Abstract

Data of investigations carried out in Lithuania have shown that after the Chernobyl NPP accident the Nemunas and Neris rivers became a transfer artery for radionuclides from polluted regions of Byelorussia on their way to the Baltic Sea. Thus, the objectives of the Project were: to study peculiarities of the ^{137}Cs migration and seasonal variations of its transfer by the Nemunas and Neris rivers, to evaluate the annual riverine input of this nuclide to Lithuania from Byelorussia in 1997–2000 as well as regularities of the ^{137}Cs penetration into the Kaunas and Klaipėda freshwater reservoirs and into the groundwater wells in the Nemunas river delta. Data on the ^{137}Cs annual flux balance in the Nemunas and Neris river water in 1998–2000 have shown that the main trend is the decrease in the ^{137}Cs annual inflow from Byelorussia with time (1996 - 3.3 Ci/year, 1998 - 1.2 Ci/year, 1999 - 1.3 Ci/year, 2000 - 0.6 Ci/year). The ^{137}Cs accumulation barrier zone of the Kaunas man-made basin from 1999 became an important source of ^{137}Cs in the river water. Investigations show that the period of the study (1998–2000) was transitional when processes of the ^{137}Cs accumulation in the Nemunas – Neris water system dominating after the Chernobyl NPP accident changed into ^{137}Cs self-cleaning ones. Formation of ^{137}Cs concentration as well as physico-chemical forms of this nuclide in the water column above the river accumulation zone is strongly affected by processes of the ^{137}Cs exchange at the bottom water-sediment interface. Seasonal data on ^{137}Cs concentrations in freshwater supplies and the well showed the ^{137}Cs penetration into the drinking water to be significant during cold season. This effect might be related to the decay of the biologically active layer of the sand buffer. Investigations of ^{137}Cs vertical profiles in flooded meadow soils as well as ^{137}Cs concentrations in water of field canals in the Nemunas river delta showed that self-cleaning of this region soils from ^{137}Cs was due to the outflow of this nuclide associated with the organic acid dissolved in the field canal water.

INTRODUCTION AND PROJECT OBJECTIVES

Radionuclides get into rivers during the accidents at Nuclear Power Plants or due to the runoff from the contaminated zones of drainage basins can be transferred with the river water over long distances from the sources of radioactive contamination through the borders of many countries. Thus data of investigations carried out in Lithuania in 1996 have shown that after the Chernobyl NPP accident the Nemunas-Neris water system became a transfer artery for radionuclides from Byelorussia on their way to the Baltic Sea. The so-called “hot” spots formed after the accident in the drainage basin of the upper reaches water system in Byelorussia were polluted with ^{137}Cs up to $5.6 \cdot 10^{11} \text{ Bq} \cdot \text{km}^{-2}$.

Radionuclide transport by rivers is accompanied by radioactive contamination of their accumulation zones, and in time bottom sediments of rivers turn into the repository of radionuclides. Measurements showed that accumulation zones disposed along the riverbed in most cases were not stable and were periodically devastating during large changes in the hydrological regime (floods and ice floatings) causing a short term significant increase in the radionuclide concentration in the river water (Tarasiuk N. et. al., 1993). Raised in this way radionuclides associated with the suspended matter can be deposited along the river flow in the next accumulation zone located below. Besides, these newly deposited sediments become totally mixed up and vertically uniform completely destroying the earlier existed time sequence of depositions.

Many years after the accident when the radionuclide run off from the contaminated catchment decreases due to the radionuclide vertical migration in catchment soils, bottom sediments of the river can become a source of the long term radioactive contamination of the river water. Information on this possibility can be obtained studying the physico-chemical forms of the suspended matter and sediments (Martinez-Aguirre A. and Garcia-Leon M., 1994; Aarkrog A. et. al., 1997; Kuznetsov J.V. et. al., 2000). This information is especially important to river stationary accumulation zones, which act as a trap for radionuclides associated with the suspended particles. One of such stationary zones was formed in the Nemunas river above the Kaunas HEPS dam in the Kaunas man-made basin. The fate of radionuclides stored in the sediments of this huge accumulation zone is a real problem for the Nemunas river.

The prognosis of the levels of secondary radioactive contamination of riverine systems due to the radionuclides stored in the bottom sediments is a goal of some modeling studies (Aarkrog A. et. al., 2000; Nosov A.B. and Martynova A.M., 1997).

Processes of the radioactive contamination of the flooded river valley and run off the long lived radionuclides from the catchment due to water erosion were studied in model experiments (Nosov A.B., 1997; Karavaeva E.N. et al., 1997). In some works, an attempt was made using the data on the long term radioactive monitoring to restore the whole time course of radioactive situations along the river below the source of the long term radionuclide release (Vorobiova M. and Degteva M.O., 1999; Vorobiova M. et al., 1999). Investigations of the radioecological situation in riverine systems and reactor cooling ponds are also continued (Mererzko A.I. et. al., 1998; Voitsekhovitch O. et. al., 1996). The goal of the study was to separate radionuclide components from global fallout, the Chernobyl NPP accident and South-Ukrainian NPP operational releases in the total radioactive pollution of the South Bug river basin (Mererzko A.I. et. al., 1998) and to present a modern concept on the current water protection and remediation activities for the areas contaminated after the 1986 Chernobyl accident (Voitsekhovitch O. et. al., 1996). The latter problems are important not only to the Chernobyl 30-km exclusion zone, and the post-accidental water protection experience can be treated as unique lessons on water protection for neighbouring countries before possible NPP accidents. Besides, it is a good hint for Lithuania as well as for the other neighbouring countries to assess a possible risk of radionuclide penetration into freshwater supplies in a present radioecological situation. In Lithuania, this problem is very urgent in rural regions, especially in the periodically flooded Nemunas river delta where up to now native inhabitants use wells. Moreover, in Kaunas and Klaipėda cities old systems of surface water filtration through sand buffers are partially used for fresh water supplies.

The present state of radioecological studies shows a lack of seasonal and annual data on radionuclide migration fluxes. Winter season data are especially important when bottom sediments and the underground water become the main source of radionuclides in the river water. In Lithuania, a particular attention must be paid to seasonal processes of the radionuclide exchange through the sediment-bottom water interface in a huge stationary accumulation zone above the Kaunas HEPS dam, which can define present seasonal features of the radiological situation in the lower reaches of the Nemunas river.

Thus, the objectives of the Project were to study peculiarities of the ^{137}Cs migration and seasonal variations of its transfer by the Nemunas and Neris rivers, to evaluate the annual riverine input of this nuclide to Lithuania from Byelorussia in 1997 – 2000 as well as regularities of the ^{137}Cs penetration into the Kaunas and Klaipėda freshwater reservoirs and into the groundwater wells in the Nemunas river delta.

Investigations were focused on seasonal variations of ^{137}Cs concentrations in the river water (total, associated with the suspended matter and in dissolved form), suspended matter concentrations, its ^{137}Cs activity and the distribution coefficient K_d of the suspended particles, vertical profiles of the ^{137}Cs specific activity and mass density in bottom sediments, determination of the character of the ^{137}Cs transfer along the Nemunas-Neris riverine system, determination of the physico-chemical forms of ^{137}Cs in the Nemunas river water and in sediments, vertical distribution of radiocesium in bottom sediments and flooded meadow soils in the Nemunas river delta.

ACTIVITIES DURING THE REPORTING PERIOD

For the reporting period (1997/12/15 – 2001/03/31), winter, spring, summer, autumn seasonal samplings were carried out. Radiocesium concentrations have been determined in the river water (total, associated with the suspended matter and in water-soluble forms), sediments, the groundwater well and freshwater reservoirs using the naturally filtered river water and soil. Sampling sites are shown in Fig. 1.



△- river water, ■- sediments, θ - soils, × - freshwater of reservoirs, ▲ - groundwater of wells, ○ - physical and chemical forms of ^{137}Cs in water and sediments.

Fig. 1. Scheme of sampling sites location.

A.) SAMPLING

Water samples in the Nemunas river were taken in Druskininkai (at the border with Byelorussia), in Darsūniškis (at the beginning of the Kaunas HEPS man-made basin), in Barevičiai (from the Kaunas HEPS man-made basin), in Kaunas (from the Kaunas HEPS basin near the dam) and in Rusnė (at about 8 km before the mouth of the Nemunas river where it inflows to the Curonian Lagoon); in the Neris river – in Buivydžiai (at the border with Byelorussia) and in Kaunas (1km above the confluence with the Nemunas river). The volume of water samples for the study of seasonal variations of radiocesium concentrations was equal to 100 L.

To study seasonal variations of radiocesium physico-chemical forms in the Nemunas river water, additional water samples (~150L) were taken in Druskininkai and in Darsūniškis during investigations in 1998; in Darsūniškis (at the beginning of the Kaunas man-made basin) and in Kaunas (from the same basin near the dam) during investigations in 1999; in Barevičiai (from the Kaunas HEPS man-made basin) during investigations in 2000.

Water samples from freshwater reservoirs were taken in Kaunas (freshwater reservoir below the Kaunas HEPS dam) and in Klaipėda (freshwater reservoir under the Vilhelm canal). The volume of these water samples was equal to 150 L.

Water samples from the groundwater well (~100L) were taken in the village Šyša (locality of Rusnė) located in the lower Nemunas river valley periodically affected by its floods.

Alongside with the water samples, sediment cores were taken in Darsūniškis, in Barevičiai and in the Vilhelm canal using a special lake sampler (surface area – 225 cm²). During warm seasons they were taken from the boat, and in winter for this purpose holes were drilled in the ice cover. Sediment cores were sliced into layers of ~ 2.0÷2.5 cm thickness and dried at room temperature.

Seasonal variations in the ¹³⁷Cs exchangeable part of its physico-chemical forms were studied in the two upper layers of the bottom sediments.

Using consecutively a special thin metal square form (height – 30 cm, open area –144 cm²), samples of flooded meadow soil were taken at up to the 90–120 cm depth in the Nemunas river delta (locality of Rusnė). These samples were sliced into layers (of 1–2 cm thickness), and radionuclide concentrations were analyzed.

PROCEDURES AND METHODS

For separate evaluation of ¹³⁷Cs concentrations in water soluble and suspended matter forms, water samples were filtered through the “Filtrak” filters (Whatman 391, particle cut off size ~ 0.45 μm). For the evaluation of the ¹³⁷Cs concentration in dissolved form, the water filtrate was treated radiochemically, using the ferrocyanide precipitation method. (Borisenko G.S. et al., 1986).

To separate the soluble anionic, cationic and neutral radionuclide species, water samples were filtered through 0.2 μm membrane filters and consecutively passed through the columns filled with strong anion (AB-17) and cation (Ky-2-8) exchangers.

Investigation of exchangeable forms of ¹³⁷Cs in bottom sediments was based on the Tessier A. et al., 1979, sequential extraction method, taking into consideration specifications of other

authors (Evans D.W. et al., 1983; Hilton J. et al., 1992). Filtering it through 0.2 µm membrane filters separated by pore water. Then sediments were consecutively extracted with 1M MgCl₂ (fraction F₂) and 1M NH₄Cl (fraction F₃).

A γ-spectrometer with the Ge(Li) semiconductor detector was used for the ¹³⁷Cs nuclide analysis of sediments and soil. The SILENA as well as ORTEC γ-spectrometric systems with the HPGe detectors were used for radionuclide analysis of water samples (specimens of standard geometry with the deposits after the radiochemical treatment of the water filtrate and filters with the suspended matter) and for the determination of ¹³⁷Cs physico-chemical forms in sediments and water (detection limit (d.l.) – 0.7 Bq·kg⁻¹, 0.1 Bq·m⁻³, respectively).

The γ-spectrometer calibration was carried out using radioactive mixture of different density (¹⁵²Eu+¹³⁷Cs) prepared by the Russian Scientific Research Institute of Physico-Technical and Radiometric Measurements (Moscow, Russia). Measurement errors of radionuclide concentrations for the γ-spectrometer with the Ge(Li) detector were calculated manually, and for the SILENA and ORTEC γ-spectrometric systems they were evaluated by the SILENA software program GAMMAPLUS and GAMMA VISION program. Errors were usually less 30 % at the 95 % confidence level (1.96 σ).

RESULTS AND DISCUSSION

I. Peculiarities of ¹³⁷Cs migration in the Nemunas – Neris water system.

Climatic conditions in Lithuania during last three years (1998–2000) were rather different, which influenced the annual debit courses of the Nemunas – Neris water system (Fig. 2–4). Thus, warm 1997/1998 winter with three floody periods was followed by rather cold and not very floody spring. Several floody periods were also fixed during summer and autumn, Fig. 2. Data of the measurements show (Table 1) that ¹³⁷Cs concentrations in the Lithuanian river water in 1998 did not peak in spring (with the exception of the Rusnė) and reached maximum values in summer mainly due to the growth of the soluble fraction of the ¹³⁷Cs concentration in water (Druskininkai, Buivydžiai, Kauno HEPS sampling sites). Fractions of ¹³⁷Cs concentrations associated with the suspended matter are also maximum in Druskininkai and Buivydžiai (at the border with Byelorussia) in summer. They are related to the maximum concentrations of the suspended matter in the river water. Low values of the partition coefficients, K_d, of the suspended particles (16.7–23.1 m³/kg) indicate their mineral origin. The Darsūniškis sampling site, located at the beginning of the Kaunas man-made basin, is the only place where K_d coefficients were measured rather high during warm period (71.4–132 m³/kg). Apparently, these values are related to the phytoplankton bloom.

The balance of the ¹³⁷Cs transfer by the Nemunas - Neris water system in 1998 was evaluated using real data of the water debit course measured at (Buivydžiai, Druskininkai) or near (Rusnė-Smalininkai) the sampling site and separately for ¹³⁷Cs fluxes in soluble and suspended matter forms, Table 4. These data show that the accumulation regime of the ¹³⁷Cs transfer in the suspended matter form dominated during all seasons in 1998. It is evident that rainy weather promoted elevated run off of ¹³⁷Cs associated with the suspended matter from the contaminated drainage basin in the upper reaches of the Nemunas – Neris water system in Byelorussia. The ¹³⁷Cs flux in the suspended matter form in Rusnė was due to coarse particles of local origin with the small partition coefficients (Table 1). Processes of ¹³⁷Cs accumulation in the soluble form, as may be seen from Table 4, were dominating in summer only. In winter, spring and autumn, a slight self-cleaning of the riverine system took place. In general, in the

total ^{137}Cs balance in the Nemunas – Neris water system processes of distinct ^{137}Cs accumulation dominated only in summer, and a very slight accumulation was in spring. In winter, the total ^{137}Cs flux was almost compensated and a slight self-cleaning effect was noticed in autumn.

In general, processes of the ^{137}Cs transfer in the Nemunas – Neris water system in 1998 may be treated as transitional when the ^{137}Cs outflow flux due to the contaminated bottom sediments of the riverine system becomes balanced by the ^{137}Cs inflow through the border with Byelorus. Climatic conditions in Lithuania in 1999 were different from those in 1998. They influenced the annual debit courses of the Nemunas and Neris rivers (Figs. 2, 3). Rivers in winter had an ice cover, a distinct floody period was observed in spring while summer was dry with its minimum debits. Winter of 1998/99 was not cold and two small floody periods were fixed. Rather dry autumn of 1999 was followed by a short floody period started at the beginning of winter (Fig. 3).

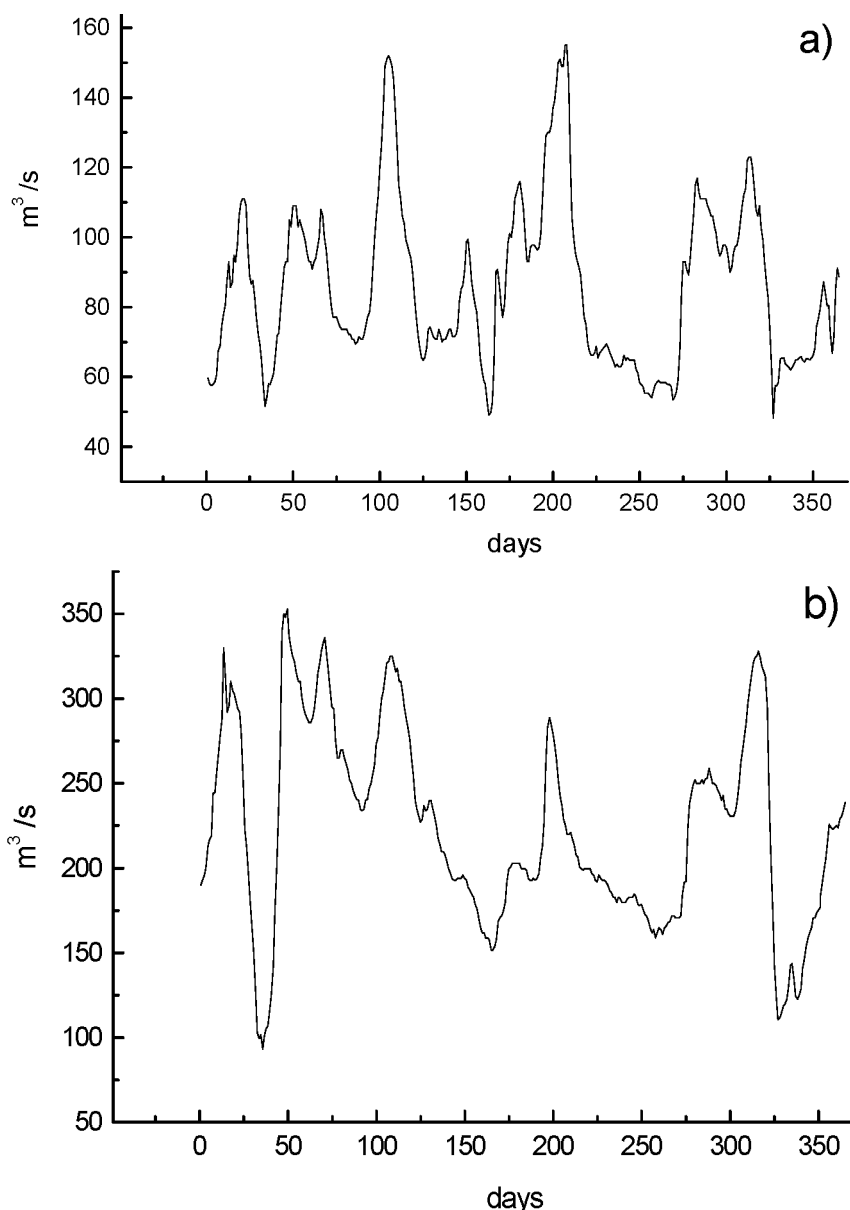

Fig. 2. Debit course of the Neris river (Buivydžiai sampling site) (a); of the Nemunas river (Druskininkai sampling site) (b), 1998.

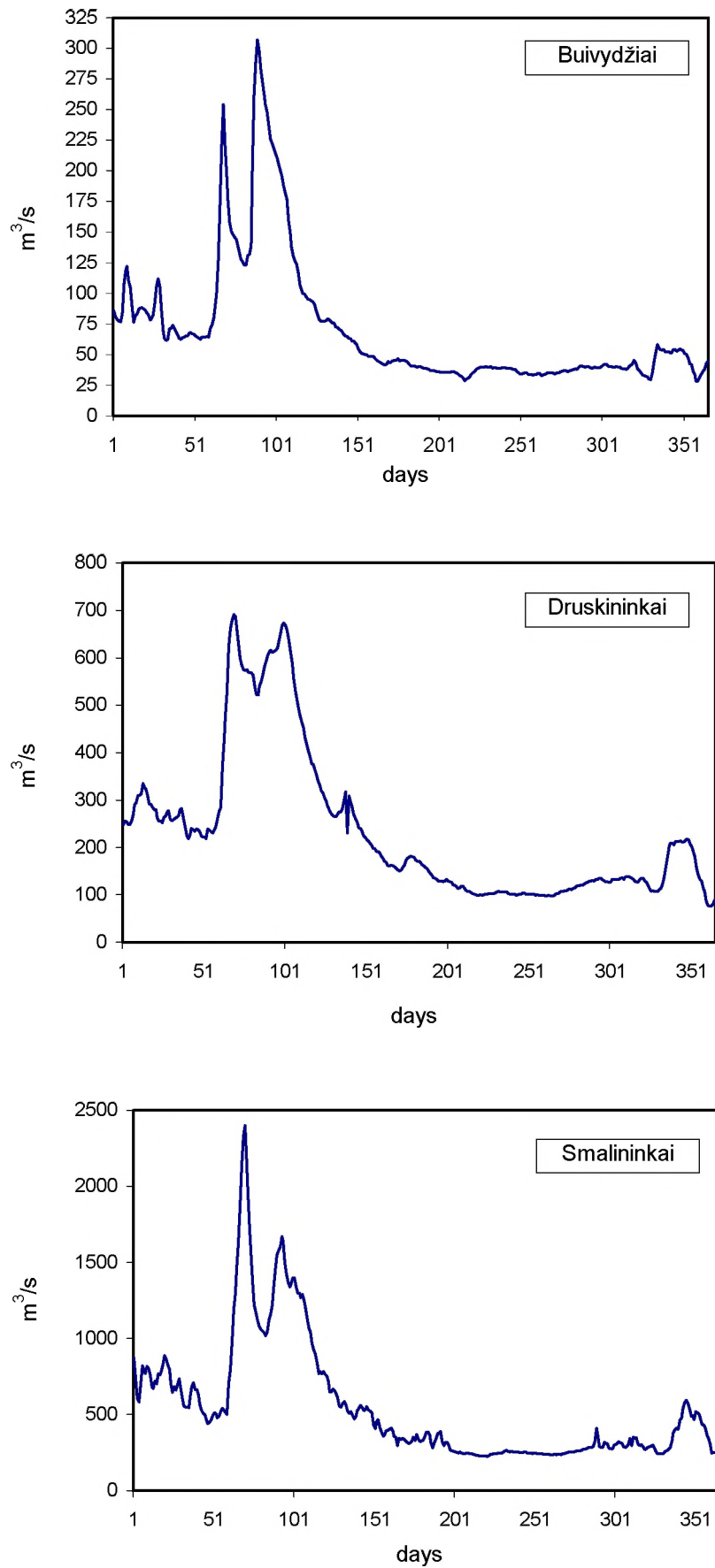

Fig. 3. Debit course of the Nemunas – Neris water system in sampling sites, 1999.

Data of the measurements of ^{137}Cs concentrations in the river water in 1999 show (Table 2) that the main trend in their course from 1996 is the decrease in the annual mean of these concentrations.

In 1999 as well as in 1998, concentration fractions of soluble in water ^{137}Cs were measured higher than associated with the suspended matter ones (Table 2). Besides, an abnormal rise in ^{137}Cs specific activities of the suspended particles, as well as in their partition coefficients was measured in the Nemunas river in winter and spring. Water sampling in the Nemunas river in winter was carried out during small flood impulse in its debit, which could cause resuspension of the bottom sediment detrits with rather high K_d coefficients. Another possibility for high ^{137}Cs partition coefficients may be an early phytoplankton bloom.

In fact, a distinct difference in the ratio of the suspended matter concentrations was measured at the beginning of the Kaunas man-made basin (Darsūniškis) and the Kaunas HEPS dam in 1999. In spite of the data in 1998 when these concentrations near the Kaunas HEPS dam were remarkably lower than the Darsūniškis ones, in 1999 they were higher near the Kaunas HEPS dam. This was due to the phytoplankton bloom during summer and autumn. It is quite possible that the early growth of phytoplankton in winter and spring is also responsible for rather large specific activities and partition coefficients of the suspended particles in winter and spring water samples. In winter, it is possible even under the transparent ice cover.

These effects show that under conditions of the decreased ^{137}Cs inflow through the Byelorussia-Lithuania border with the Nemunas river water, the ^{137}Cs accumulation barrier zone of the Kaunas man-made basin becomes an important source of ^{137}Cs in the river water affecting the concentration not only of ^{137}Cs soluble in the water but also its part associated with the suspended matter.

Seasonal peculiarities of the ^{137}Cs transfer through the Lithuanian territory by the Nemunas – Neris water system in 1999 were studied using the real debit courses at Druskininkai, Buivydžiai and Rusnė (Smalininkai) sampling sites. For all seasons, ^{137}Cs balances were evaluated separately for soluble in water and associated with the suspended matter radionuclide activity concentrations, Table 5. These data show that in 1999 processes of the Nemunas – Neris water system self-cleaning were dominating in the ^{137}Cs balance in soluble in water all over the year. Spring flood as well as winter conditions especially promoted these processes in the bottom sediments. The ^{137}Cs flux in soluble form through the border with Byelorussia was minimum in autumn and amounted to 9 times less than the spring one.

Data on the ^{137}Cs balance associated with the suspended matter form show a permanent accumulation of this ^{137}Cs component in 1999. As a result, data on the total ^{137}Cs flux seasonal balance in 1999 show a distinct domination of self-cleaning processes in winter and spring. A slight accumulation effect took place in summer and autumn.

Water debit annual courses measured at Buivydžiai, Druskininkai and Rusnė (Smalininkai) sampling sites in 2000 are depicted in Fig. 4. As it may be seen there were two flood periods in January and February followed by the long term spring flood. Rains started in the middle of July and caused several peaks of summer floods. The flood period having started in the late autumn continued to December.

Data of the measurements of ^{137}Cs activity concentrations (total in soluble and suspended matter forms), concentrations of the suspended particles, their ^{137}Cs specific activities and partition coefficients K_d in water samples taken seasonally in the Nemunas – Neris water system in 2000 are presented in Table 3. The Barevičiai sampling site located below the

Darsūniškis at the distance of about 15 km was chosen to study ^{137}Cs migration processes inside the accumulation zone formed in the Kaunas man-made basin.

Comparison of 2000 data with the 1999 ones shows (Tables 2 and 3) that total and associated with the suspended matter ^{137}Cs activity concentrations in river water at the border with Byelorussia (Druskininkai, Buivydžiai) in 2000 were, in general, slightly less than the 1999 ones. Besides, conditions for the ^{137}Cs accumulation in phytoplankton in the Kaunas man-made basin (Darsūniškis, Kaunas HEPS sites) in 2000 were worse than those in 1999. Thus, partition coefficients K_d of the suspended particles during warm seasons in 2000, in general, were there less than those in 1999 although it was noticed that high phytoplankton concentrations in the water may be related to rather small partition coefficients of the suspended matter. Thus, (Table 3) obvious phytoplankton samples taken during phytoplankton blooms in autumn 2000 (Druskininkai, Darsūniškis, Barevičiai) were distinguished for rather low K_d (15, 11, 34 – respectively). On the contrary, small phytoplankton concentrations (Kaunas HEPS sample in summer 2000 and Buivydžiai sample in autumn 1999) may be responsible for comparatively large ^{137}Cs activity concentrations associated with the suspended matter (phytoplankton). Apparently, ^{137}Cs accumulation abilities of phytoplankton depend on its age and speciations.

Data on the ^{137}Cs seasonal balance in the Nemunas – Neris water system in 2000 in soluble and suspended matter forms are presented in Table 6. Comparing with the 1999 ones (Table 5), these data are distinguished for the significantly decreased ^{137}Cs inflow through the border with Byelorussia in winter and spring. Another striking feature is that this flux is almost constant during winter, spring and summer seasons. It does not depend on the inflowing debit. Thus, the only limitation for this ^{137}Cs flux may be processes of the ^{137}Cs diffusion through the sediment bottom water interface. Data on the ^{137}Cs seasonal balance in soluble form show that processes of the Nemunas – Neris water system self-cleaning from radionuclides continued in 2000. In autumn, the ^{137}Cs flux in soluble form once more decreased and became balanced (Table 6). Data on the ^{137}Cs seasonal balance in the suspended matter form in 2000, Table 6, show that during warm seasons (spring, summer, autumn) processes of the ^{137}Cs accumulation were dominating in the Nemunas – Neris water system. Due to these effects, in general, processes of the ^{137}Cs transfer in the Nemunas – Neris water system in 2000 were distinguished for slight accumulation of this radionuclide in spring and autumn and an evident self-cleaning domination in winter and summer.

For the evaluation of trends in the ^{137}Cs migration regime in the Nemunas – Neris water system for 1996–2000 data on the balance of four seasons sums of ^{137}Cs inflowing and outflowing fluxes can be used as a first approximation. It is a rather rough comparison but at present seasonal measurement data give us only this possibility. For the first time this balance method was used for 1996 ^{137}Cs migration data. A difference in the sums of four season ^{137}Cs inflowing and outflowing fluxes (15520 and 10400 $\text{Bq}\cdot\text{s}^{-1}$, respectively) showed that in general a regime of the ^{137}Cs accumulation in the Nemunas – Neris water system dominated in 1996 and almost 33 % of the ^{137}Cs inflow was accumulated by the bottom sediments. A similar assessment carried out in 1998 showed that sums of ^{137}Cs inflowing and outflowing fluxes decreased up to 5730 and 4940 $\text{Bq}\cdot\text{s}^{-1}$, respectively, and only 14 % of the ^{137}Cs inflow was accumulated. Although the sum of ^{137}Cs inflowing fluxes in 1999 slightly increased as compared with the 1998 one (6060 $\text{Bq}\cdot\text{s}^{-1}$), processes of self-cleaning from ^{137}Cs became dominating and the ^{137}Cs outflowing flux sum was 41 % larger than the inflowing one (8560 $\text{Bq}\cdot\text{s}^{-1}$). The same ^{137}Cs migration regime was established in 2000, although the ^{137}Cs flux sum balance components decreased significantly (2600 – 3620 $\text{Bq}\cdot\text{s}^{-1}$, respectively).

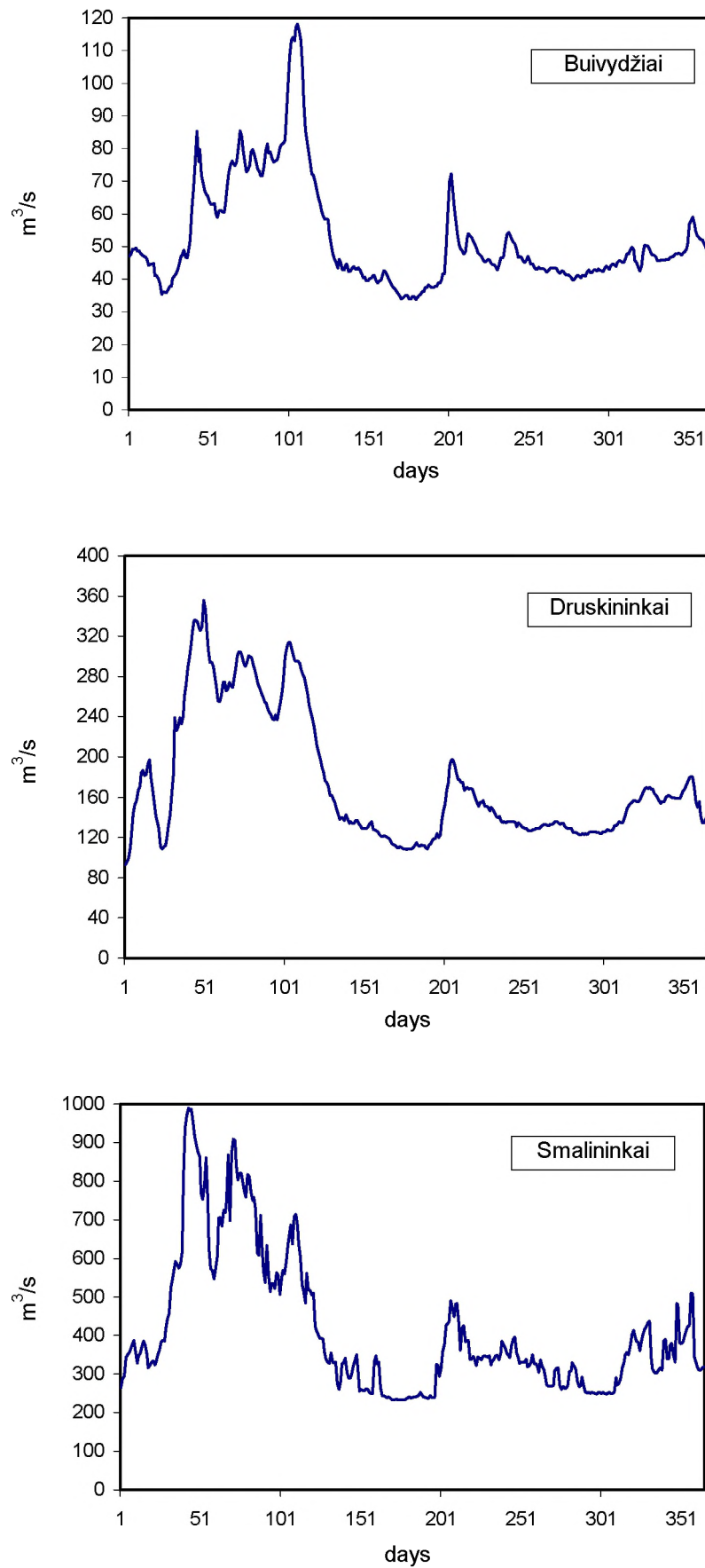

Fig. 4. Debit course of the Nemunas – Neris water system in sampling sites, 2000.

TABLE 1. Data on ^{137}Cs content (Σ - total, φ - soluble form, Ψ - suspended matter), suspended matter concentration (M_{sm}) and their ^{137}Cs specific activity (A), partition coefficient (K_d) in winter –I, spring - II, summer - III, - autumn – IV in Lithuanian rivers in 1998.

Sampling site	Σ, Bqm^{-3}				φ, Bqm^{-3}				ΨBqm^{-3}				$M_{\text{sm}}, \text{gm}^{-3}$				$A_{\text{sm}}, \text{Bqkg}^{-1}$				$K_d, \text{m}^3\text{kg}^{-1}$			
	I	II	III	IV	I	II	III	IV	I	II	III	IV	I	II	III	IV	I	II	III	IV	I	II	III	IV
Nemunas river basin																								
Druskininkai	2.9	4.5	5.6	3.6	2.3	3.2	3.8	2.1	0.6	1.3	1.8	1.5	14.7	22.3	28.3	16.7	40.8	58.3	63.6	89.8	17.7	18.2	16.7	42.8
Darsūniškis	1.7	2.0	2.3	1.3	1.2	1.1	0.6	0.7	0.5	0.9	1.7	0.6	20.5	21.4	21.4	12.0	24.4	42.1	79.4	50.0	20.3	38.3	132	71.4
Kaunas HEPS	1.7	1.8	2.9	1.0	1.7	1.7	2.3	0.7	0	0.1	0.6	0.3	3.1	7.0	11.6	8.0	0	14.3	51.7	37.5	0	8.7	22.5	53.6
Rusnė	0.8	3.3	2.1	2.4	0.8	2.8	1.6	1.7	0	0.5	0.5	0.7	21.3	28.6	35.0	20.1	0	17.6	14.3	34.8	0	6.3	8.9	20.5
Neris river basin																								
Buivydžiai	5.4	3.9	12.1	2.3	4.5	3.1	7.8	1.3	0.9	0.8	4.3	1.0	18.8	13.2	23.9	9.8	47.9	60.6	180	102	10.6	19.5	23.1	78.5
Kaunas	1.1	1.4	1.4	1.1																				

TABLE 2. Data on ^{137}Cs content (Σ - total, ϕ - soluble form, Ψ - suspended matter), suspended matter concentration (M_{sm}) and their ^{137}Cs specific activity (A), partition coefficient (K_d) in winter –I, spring - II, summer - III, - autumn – IV in Lithuanian rivers in 1999.

Sampling site	Σ, Bqm^{-3}				ϕ, Bqm^{-3}				ΨBqm^{-3}				M_{sm}, gm^{-3}				A_{sm}, Bqkg^{-1}				$K_d, \text{m}^3\text{kg}^{-1}$			
	I	II	III	IV	I	II	III	IV	I	II	III	IV	I	II	III	IV	I	II	III	IV	I	II	III	IV
Nemunas river basin																								
Druskininkai	3.7	3.2	4.5	2.9	2.6	1.6	2.9	1.4	1.1	1.6	1.7	1.2	8.2	22.3	60.0	21.8	134	71.7	28.3	55.0	52	45	9.8	39
Darsūniškis	1.4	1.3	1.6	1.2	1.1	0.7	0.9	1.1	0.3	0.6	0.7	0.1	3.6	9.7	10.3	4.5	83	62	68.0	22.2	75	88	76	22
Kaunas HEPS	0.5	0.9	1.4	0.8	0.1	0.6	0.8	0.5	0.4	0.3	0.6	0.3	6.4	11.3	16.3	5.5	63	27	37	54.5	630	45	46	110
Rusnė	2.1	4.7	1.9	1.5	1.9	4.0	1.7	1.2	0.2	0.7	0.2	0.3	8.9	18.1	20.5	12.9	22.5	38.7	9.8	23	12	9.7	5.7	19
Neris river basin																								
Buivydziai	9.2	5.2	3.1	1.9	8.3	3.0	2.4	1.4	0.9	2.2	0.7	0.5	17.6	49.3	21.3	6.0	51	45	33	83	6.2	15	14	59
Kaunas	0.8	1.6	1.1	1.2																				

TABLE 3. Data on ^{137}Cs content (Σ - total; ϕ - soluble form: cationic, anionic, neutral; Ψ - suspended matter), suspended matter concentration (M_{sm}) and their ^{137}Cs specific activity (A), partition coefficient (K_d) in winter –I, spring - II, summer - III, - autumn – IV in Lithuanian rivers in 2000.

Sampling site	Σ, Bqm^{-3}				ϕ, Bqm^{-3}				ΨBqm^{-3}				$M_{\text{sm}}, \text{gm}^{-3}$				$A_{\text{sm}}, \text{Bqkg}^{-1}$				$K_d, \text{m}^3\text{kg}^{-1}$			
	I	II	III	IV	I	II	III	IV	I	II	III	IV	I	II	III	IV	I	II	III	IV	I	II	III	IV
Nemunas river basin																								
Druskininkai	2.3	3.2	4.7	1.7	2.0	2.0	3.1	1.3	0.3	1.2	1.6	0.4	9.9	16.5	33.6	21.2	33	72	58	20	17	36	19	15
Darsūniškis	1.4	1.3	4.4	1.8	0.8	1.1	4.2	1.4	0.6	0.2	0.2	0.4	8.8	9.8	5.6	24.1	70	24	38	16	88	22	9	11
Barevičiai	1.8	1.2	1.4	1.1	1.0	0.8	1.2	0.7	0.8	0.4	0.2	0.4	11.1	12.9	6.3	17.0	72	31	32	24	72	39	27	34
Cationic					0.4	0.4	1.0	0.7																
Anionic					0.3	0.2	d. l.	d. l.																
Neutral					0.3	0.2	0.2	d. l.																
Kaunas HEPS	0.8	1.6	3.6	1.5	0.8	1.5	3.0	1.4	d. l.	d. l.	0.6	0.2	2.5	3.3	3.5	4.6	-	-	170	43	-	-	57	31
Rusnė	1.9	1.4	3.2	0.8	1.4	1.1	2.9	0.8	0.5	0.3	0.3	d. l.	11.0	10.0	35.0	5.9	45	30	8.6	-	32	27	3.0	-
Neris river basin																								
Buivydziai	2.1	1.7	1.6	1.6	1.3	0.8	1.1	1.3	0.8	0.9	0.5	0.3	10.3	12.1	27.0	6.7	80	75	20	45	62	94	18	36
Kaunas	1.3	0.7	0.9	0.7																				

d. l. – detection limit

TABLE 4. Data on ^{137}Cs balance in the Nemunas – Neris water system in 1998.

Seasons	^{137}Cs flux, $\text{Bq}\cdot\text{s}^{-1}$			
	Soluble form		Suspended matter form	
	Inflow	Outflow	Inflow	Outflow
Winter	620	740	140	d. l.
Spring	1470	1630	530	290
Summer	1250	790	630	250
Autumn	630	880	460	360

TABLE 5. Data on ^{137}Cs balance in the Nemunas – Neris water system in 1999.

Seasons	^{137}Cs flux, $\text{Bq}\cdot\text{s}^{-1}$			
	Soluble form		Suspended matter form	
	Inflow	Outflow	Inflow	Outflow
Winter	1180	2470	310	260
Spring	1910	4240	1670	740
Summer	390	430	190	50
Autumn	210	300	190	70

TABLE 6. Data on ^{137}Cs balance in the Nemunas – Neris water system in 2000.

Seasons	^{137}Cs flux, $\text{Bq}\cdot\text{s}^{-1}$			
	Soluble form		Suspended matter form	
	Inflow	Outflow	Inflow	Outflow
Winter	520	1100	110	390
Spring	560	620	370	170
Summer	510	1020	260	110
Autumn	210	200	62	d. l.

TABLE 7. Seasonal data of ^{137}Cs physico-chemical forms in the Nemunas river water in Druskininkai and Darsūniškis, 1998 (Susp.m. – suspended mater form, -An – anionic, +Cat – cationic, Non-ionic forms, Σ - total concentration).

Sampling site	Fraction	Season							
		Winter		Spring		Summer		Autumn	
		Bq/m ³	%	Bq/m ³	%	Bq/m ³	%	Bq/m ³	%
Druskininkai	Susp.m.	0.6	21	1.3	29	1.8	32	1.5	42
	-An	0.6	21	1.3	29	1.3	23	0.5	14
	+Cat	0.8	27	0.8	18	1.7	31	0.9	25
	Non-ionic	0.9	31	1.1	24	0.8	14	0.7	19
	Σ	2.9		4.5		5.6		3.6	
Darsūniškis	Susp.m.	0.5	29	0.9	45	1.7	73	0.6	46
	-An	0.5	29	0.7	35	0.2	9	0.5	38
	+Cat	0.3	18	0.2	10	0.2	9	0.1	8
	Non-ionic	0.4	24	0.2	10	0.2	9	0.1	8
	Σ	1.7		2.0		2.3		1.3	

TABLE 8. Seasonal data of ^{137}Cs physico-chemical forms in the Nemunas river water in Kaunas HEPS and Darsūniškis, 1999. (Susp.m. – suspended mater form, -An – anionic, +Cat – cationic, Non-ionic forms, Σ - total concentration).

Sampling site	Fraction	Season							
		Winter		Spring		Summer		Autumn	
		Bq/m ³	%	Bq/m ³	%	Bq/m ³	%	Bq/m ³	%
Kaunas HEPS	Susp.m.	0.4	80	0.3	33	0.6	43	0.3	38
	-An	d.l.		0.2	22	0.1	7	0.1	12
	+Cat	0.1	20	0.4	45	0.7	50	0.4	50
	Non-ionic	d.l.		d.l.		d.l.		d.l.	
	Σ	0.5		0.9		1.4		0.8	
Darsūniškis	Susp.m.	0.3	22	0.6	46	0.7	44	0.1	8
	-An	d.l.		0.3	23	0.2	12	0.1	8
	+Cat	0.2	14	0.4	31	0.6	38	0.6	50
	Non-ionic	0.9	64	d.l.		0.1	6	0.4	34
	Σ	1.4		1.3		1.6		1.2	

TABLE 9. Seasonal data of ^{137}Cs physico-chemical forms in the Nemunas river water in Barevičiai, 2000. (Susp.m. – suspended mater form, -An – anionic, +Cat – cationic, Non-ionic forms, Σ - total concentration).

Sampling site	Fraction	Season							
		Winter		Spring		Summer		Autumn	
		Bq/m ³	%	Bq/m ³	%	Bq/m ³	%	Bq/m ³	%
Barevičiai	Susp.m.	0.8	44	0.4	33	0.2	14	0.4	36
	-An	0.3	17	0.2	17	d.l.		d.l.	
	+Cat	0.4	22	0.4	33	1.0	72	0.7	34
	Non-ionic	0.3	17	0.2	17	0.2	14	d.l.	
	Σ	1.8		1.2		1.4		1.1	

TABLE 10. Seasonal shares (%) of ^{137}Cs exchangeable forms in the bottom sediments in Darsūniškis.

Fractions	Seasons							
	winter		spring		summer		autumn	
	1998	1999	1998	1999	1998	1999	1998	1999
I layer								
F ₂ (MgCl ₂)	1.5	1.1	4.0	1.2	0.4	0.5	d.l.	d.l.
F ₃ (NH ₄ Cl)	9.2	7.9	7.8	4.7	6.0	4.2	5.6	7.8
Residue	89.3	91.0	88.2	94.1	93.6	95.3	94.4	92.2
II layer								
F ₂ (MgCl ₂)		1.4		1.8		1.8		0.8
F ₃ (NH ₄ Cl)		4.3		5.3		2.4		3.8
Residue		94.3		92.9		95.8		95.4

TABLE 11. Seasonal shares (%) of ^{137}Cs exchangeable forms in the surface layer of the bottom sediments in 2000.

Fractions	Seasons							
	winter		spring		summer		autumn	
	Darsūniškis	Barevičiai	Darsūniškis	Barevičiai	Darsūniškis	Barevičiai	Darsūniškis	Barevičiai
F ₂ (MgCl ₂)	1.0	-	0.5	1.5	d.l.	d.l.	d.l.	d.l.
F ₃ (NH ₄ Cl)	6.1	-	3.2	4.0	4.0	4.2	6.2	5.5
Residue	92.9	-	96.3	94.5	96.0	95.8	93.8	94.5

TABLE 12. Seasonal data of the ^{137}Cs total concentrations in drinking water, soluble ^{137}Cs concentrations in the surface waters (the Nemunas river –Rusnė, Kaunas man-made basin, Vilhelm canal) and ^{137}Cs penetration coefficient.

Sampling site	Seasons			
	winter	spring	summer	autumn
	^{137}Cs , Bq/m ³			
Kaunas city freshwater supply	3.2	0.35	0.3	0.4
Kaunas HEPS	1.7	1.7	2.3	0.7
Penetration coefficient	1.90	0.21	0.13	0.57
Klaipėda city freshwater supply	4.7	0.7	0.5	1.6
Vilhelm canal	3.0	2.6	2.1	4.5
Penetration coefficient	1.57	0.27	0.24	0.36
Private well	10.9	1.4	1.3	0.8
Rusnė	0.8	2.8	1.6	1.7
Penetration coefficient	13.6	0.5	0.8	0.5

II. DETERMINATION OF THE PHYSICO-CHEMICAL FORMS OF ^{137}CS IN THE NEMUNAS RIVER WATER

The seasonal course of ^{137}Cs physico-chemical forms in 1998 was studied in the Nemunas river water samples from Druskininkai and Darsūniškis, Table 7. Due to low ^{137}Cs concentrations in the river water in Darsūniškis, this study consumed a lot of γ -spectrometric time. Nevertheless, low accuracy of the data (~50 %) allows us to discuss only the trends in their changes.

In Druskininkai, ^{137}Cs cationic form is maximum in summer and is related to the forced run off of this nuclide from the drainage basin. In winter, it is fed by river sediments and is almost a half of the summer one. Data show that in spring and autumn bottom sediments were apparently the main source of this fraction in the river water.

Non-ionic fraction of the ^{137}Cs concentration was almost constant during the year and thus may also be related to river sediments.

The ^{137}Cs concentration anionic fraction has the same maximum value in spring and summer and is almost half maintained by flux from sediments. It is known that this fraction is related to the organic substances negatively charged. During floody seasons a lot of them in the form of organic acids is run off to the river from the drainage basin.

Apparently, there are two main causes of low ^{137}Cs concentrations in the Nemunas river water in Darsūniškis. The first one is the dilution of the river water from Byelorussia contaminated with ^{137}Cs by cleaner local waters. The second cause is related to the peculiarities of the Darsūniškis sampling site. Darsūniškis is located at the beginning of the huge accumulation zone – the Kaunas man-made basin, where the ^{137}Cs exchange between water column and bottom sediments takes place. The hydrodynamic regime of the river in Darsūniškis looks like that of the lake – low water flow (~0.2 m/s) and large depth (9 m at the fareway).

Table 13. Data on the vertical profiles of ^{137}Cs activity concentrations in sediment cores.

Seasons															
Winter				Spring				Summer				Autumn			
Layer, No	ρ , g·L ⁻¹	A, Bq·kg ⁻¹ ^{137}Cs	A, Bq·kg ⁻¹ ^{40}K	Layer, No	ρ , g·L ⁻¹	A, Bq·kg ⁻¹ ^{137}Cs	A, Bq·kg ⁻¹ ^{40}K	Layer, No	ρ , g·L ⁻¹	A, Bq·kg ⁻¹ ^{137}Cs	A, Bq·kg ⁻¹ ^{40}K	Layer, No	ρ , g·L ⁻¹	A, Bq·kg ⁻¹ ^{137}Cs	A, Bq·kg ⁻¹ ^{40}K
1998 - Daršūniškis															
A 1	261	60	420	A 1	251	48	360	A 1	258	56	380	A 1	237	55	370
2	270	55	380	2	252	59	410	2	259	58	350	2	286	56	380
3	328	58	430	3	264	61	430	3	261	55	370	3	285	53	340
4	436	50	420	4	311	62	400	4	307	56	380	4	330	55	400
B 1	257	57	350	5	353	59	440	5	317	54	400	5	369	52	400
2	278	58	380	6	412	59	440	6	366	56	402	6	388	57	430
3	331	55	410	7	452	56	440	7	369	52	420	7	472	54	430
4	401	60	450									B 1	227	51	490
												2	256	45	400
												3	300	54	331
												4	321	55	370
												5	362	54	420
												6	400	56	460
1998 - Vilhelm canal															
A 1	145	85	750	A 1	159	120	550	A 1	137	110	520	A 1	147	97	540
2	152	110	540	2	160	110	550	2	154	110	580	2	148	110	590
3	150	130	680	3	161	120	590	3	161	100	530	3	153	110	600
4	160	120	630	4	168	130	590	4	171	110	550	4	152	100	590
5	166	120	660	5	199	130	670	5	183	130	610	5	172	110	670
6	193	160	610	6	195	150	530	6	191	160	540	6	197	130	690
				7	216	150	620	7	193	140	480	7	198	140	590
				B 1	139	110	540					8	202	140	640
				2	149	120	550								
				3	147	110	590								
				4	173	120	640								
				5	181	130	630								
				6	197	140	650								
				7	237	140	630								

continued

1999 – Darsūniškis															
A 1	267	53	390	A 1	282	50	490	A 1	250	48	400	A 1	175	52	330
2	266	50	360	2	297	48	420	2	301	50	400	2	223	52	350
3	268	55	340	3	309	54	380	3	307	51	400	3	294	51	400
4	333	50	360	4	297	52	410	4	330	50	370	4	314	48	480
5	355	55	440	5	308	50	360	5	340	51	370	5	343	48	470
6	433	51	420	6	342	50	410	6	356	53	410	6	614	49	280
				7	382	53	430								
2000 – Darsūniškis															
A 1	224	50	390	A 1	241	56	380	A 1	260	51	380	A 3	346	40	390
2	241	51	390	2	258	50	410	2	267	51	390	4	509	40	430
3	287	53	410	3	263	57	430	3	271	49	390				
4	328	47	380	4	323	43	400	4	305	49	420				
5	383	51	380	5	364	58	380	5	366	45	390				
6	446	51	430	6	453	45	480	6	383	47	370				
								7	435	49	420				
2000 - Barevičiai															
				A 1	213	52	360	A 1	163	51	390	A 1	268	57	390
				2	218	54	380	2	173	53	350	2	266	56	410
				3	247	48	390	3	221	55	360	3	287	59	410
				4	254	56	420	4	245	56	360	4	302	55	410
				5	275	52	490	5	271	55	370	5	335	58	390
				6	281	54	360	6	310	57	390	6	344	58	380
								7	353	55	390				

TABLE 14. ^{137}Cs and ^{40}K vertical profiles in soil core in summer, 1998.

depth, cm	0-2	2-4	4-6	6-8	8-10	10-12	12-14	14-16	16-18	18-20
^{137}Cs , Bq/kg	33	27	26	34	30	26	20	21	24	38
Bq/m ²	360	310	300	450	370	310	170	220	280	380
^{40}K , Bq/kg	330	320	300	320	280	270	290	270	250	240
depth, cm	20-22	22-24	24-26	26-28	28-30	30-32	32-34	34-36	37-38	39-40
^{137}Cs , Bq/kg	36	23	15	16	13	12	12	2	1	3.7
Bq/m ²	320	180	110	190	100	80	70	10	4.24	17.5
^{40}K , Bq/kg	160	120	110	110	100	120	120		52	60
depth, cm	40-42	42-44	44-46	46-48	48-50	50-52	52-54	54-56	56-58	58-60
^{137}Cs , Bq/kg	0.7									3.8
Bq/m ²	2.84									23.6
^{40}K , Bq/kg	8	22	16	22			65		18	22
depth, cm	60-62	62-64	64-66	66-68	68-70	70-72	72-74	74-76	76-78	78-80
^{137}Cs , Bq/kg	2.6									
Bq/m ²	8.0									
^{40}K , Bq/kg	7		17							21
depth, cm	80-82	82-84	84-86	86-88	88-90	90-92	92-94	94-96	96-98	98-100
^{137}Cs , Bq/kg										
Bq/m ²										
^{40}K , Bq/kg										
depth, cm	100-102	102-104	104-106	106-108	108-110	110-112	112-114	114-116	116-118	118-120
^{137}Cs , Bq/kg									~0.6	
Bq/m ²									~1.6	
^{40}K , Bq/kg										

The ^{137}Cs concentration associated with the suspended matter is maximum during the phytoplankton bloom, Table 7. Due to the active consumption of the ^{137}Cs soluble forms by phytoplankton, their concentrations are minimum during summer and autumn.

Data of Table 8 show that climatic conditions in 1999 promoted an early phytoplankton growth in the Kaunas HEPS man-made basin. ^{137}Cs activity concentrations associated with the suspended particles were significant in Darsūniškis and near the Kaunas HEPS dam sampling sites even in winter and reached their maximum values in summer (0.7 Bq·m⁻³ in Darsūniškis and 0.6 Bq·m⁻³ near the Kaunas HEPS dam). Cationic fraction of ^{137}Cs activity concentrations in the soluble in water form in these sampling sites grew from winter to summer and autumn. This growth was probably related to the increase in the ^{137}Cs cation supply from the bottom sediments. Anionic fractions of ^{137}Cs activity concentrations in the

soluble in water form all the time were very low and reached their maximum values in spring. Neutral fractions of the soluble in water form of ^{137}Cs activity concentrations near the Kaunas HEPS dam were always below d.l., but in Darsūniškis in winter rather large values ($0.9 \text{ Bq}\cdot\text{m}^{-3}$) of this fraction were measured. Maybe, it is related to the decay of phytoplankton particles during the filtration of the winter water sample. In this case, this fraction should belong to the ^{137}Cs activity concentration associated with the suspended substances.

Data from Table 3 show that the Barevičiai sampling site is rather specific. It is located in the vicinity of the Kruonis accumulation HEPS and local peculiarities of the surface water circulation could affect measurement data (discrepancies in ^{137}Cs activity concentrations in summer and autumn water samples in Darsūniškis and Barevičiai, Table 3).

From this point of view the use of Barevičiai water samples for analysis of ^{137}Cs physico-chemical forms was not justified, although this information became accessible later. Nevertheless, the seasonal course of the cationic form of ^{137}Cs activity concentrations in the Barevičiai water samples in 2000 looks like that in Darsūniškis in 1999, Tables 8 and 9. Anionic and neutral forms are significant in winter and spring and are always less than cationic ones. We suggest that the influence of the upper basin of the Kruonis accumulation HEPS to Barevičiai water is restricted by the surface layer and at the bottom ^{137}Cs activity concentrations typical of Darsūniškis dominate.

III. DETERMINATION OF THE PHYSICO-CHEMICAL FORMS OF ^{137}CS IN THE NEMUNAS RIVER BOTTOM SEDIMENTS.

Data on seasonal variations of ^{137}Cs exchangeable forms in the surface layers of the bottom sediments in Darsūniškis in 1998–1999 and in Darsūniškis and Barevičiai in 2000 are presented in Tables 10 and 11, respectively. These data allow us to understand how tightly processes of the ^{137}Cs transfer in the Nemunas – Neris water system are bound with peculiarities of this radionuclide migration in bottom sediments. As it may be seen from Tables 10 and 11, in contrast to fraction F_3 (extracted with NH_4Cl), the seasonal course of ^{137}Cs exchangeable form F_2 is evident. In the first layer of the bottom sediments in Darsūniškis in 1998, it was maximum in spring (Table 10) and decreased during warm seasons up to the value of the detection limit in autumn. This effect was caused by a decrease in the ^{137}Cs concentration in the river water in soluble form due to the radionuclide accumulation in phytoplankton. Thus, phytoplankton bloom in the river water inside the accumulation zone caused a decrease of ^{137}Cs exchangeable form F_2 in the surface layer of the sediments

The 1999 seasonal course of ^{137}Cs exchangeable forms was studied in the two upper sediment layers (each of about 2 cm thickness) in Darsūniškis. These data are shown in Table 10. In spring, 1999, the peak of ^{137}Cs exchangeable form was not so evident, but the character of its decrease in summer and autumn was almost the same. Seasonal fractions of ^{137}Cs form F_2 in the second layer of the sediments in Darsūniškis in 1999 (Table 10) were always larger than those in the surface, providing this ^{137}Cs exchangeable form gradient.

Measurements of the seasonal variations of ^{137}Cs exchangeable forms in the first layer of sediments in Darsūniškis (at the beginning of the accumulation zone) and Barevičiai (inside the accumulation zone) in 2000 were carried out to reveal the difference in their seasonal courses. Although in winter sediment cores in Barevičiai were not accessible, spring data show ^{137}Cs form F_2 in the Barevičiai surface sediment layer to be larger than that in Darsūniškis. But in summer and autumn, ^{137}Cs exchangeable form F_2 in the surface layer of

Darsūniškis as well as of Barevičiai sediments was completely exhausted. In this case we may suggest that processes of form F_2 elimination in Barevičiai surface sediments were as those in Darsūniškis with some delay. Besides, maximum values of ^{137}Cs form F_2 in 2000 were shifted from spring up to winter and were less than those in 1999 and 1998. Thus, these data prove that during every winter concentration of ^{137}Cs exchangeable form F_2 in the surface layer of the sediments is restored but at a smaller level than earlier. The study of the seasonal variations of F_2 form gradients in the sediment surface layer could help in modeling of the accumulation zone function as a radionuclide source for the riverine system.

IV. RADIOCESIUM IN WATER FROM FRESHWATER RESERVOIRS AND THE GROUNDWATER WELL.

Penetration of radiocesium to the drinking water was studied in Kaunas city, Klaipėda city freshwater supplies and in the lower flooded valley of the Nemunas river, when the samples of water were taken from the private well. In Klaipėda city, one of the water supplies is based on the filtering of the water from the Vilhelm canal through the sand buffer. This water supply is located in the southern part of the Klaipėda city. Water samples (150L) were taken from one of the eight control pumping stations deployed along the bank of the Vilhelm canal. In Kaunas city, part of its water supplies is based on the filtering of the water from the Kaunas man-made basin through the sand buffer of the dam. This water supply is located on the Nemunas riverbank at the distance of about 1.5 km below the Kaunas HEPS dam. The private well used for water sampling is located near Rusnė on the opposite Nemunas riverbank at about 200 m below the bridge through the Nemunas river on the road Rusnė-Šilutė.

Seasonal data of the ^{137}Cs total concentrations in drinking water of the freshwater supplies and the private well as well as soluble ^{137}Cs concentrations in the Vilhelm canal and the Nemunas river (Rusnė and Kaunas man-made basin) and ^{137}Cs penetration coefficients are shown in Table 12. The main feature of the ^{137}Cs penetration into the drinking water is that this effect is maximum in cold seasons and may considerably exceed a unity. As a matter of fact the so-called “slow” filtration of the surface waters through the sand buffer is related to the existence of a thin biologically active layer on the sand buffer surface (Kuznecov I.V. et al., 1974). So, the forced ^{137}Cs penetration into the drinking water may be related to the decay of the biologically active layer of the sand buffer during cold seasons.

V. MONITORING OF ^{137}CS ACTIVITY CONCENTRATIONS IN SEDIMENTS.

- a) In the Vilhelm canal (freshwater supply of the Klaipėda city), sediment cores were taken seasonally during 1998 directly before the pumping station from the 6 m depth. For this purpose, an inflate boat was used.

Data on the vertical profiles of ^{137}Cs activity concentrations in sediment cores are presented in Table 13. Sediment density vertical profiles were measured as well as to be convinced in the natural character of the sedimentation process. All sediment samples consisted of black silts and high activity concentrations of ^{40}K in the 520–750 $\text{Bq}\cdot\text{kg}^{-1}$ range were characteristic of them. Vertical profiles of ^{137}Cs concentrations in sediment samples show them to grow with depth and reach maximum values at the cores bottom (140–160 $\text{Bq}\cdot\text{kg}^{-1}$). Mean values of ^{137}Cs activity volume concentrations in the samples varied in the range 20.1–23.3 $\text{Bq}\cdot\text{L}^{-1}$.

- b) Data on the monitoring of the vertical profiles of ^{137}Cs activity concentrations in sediment cores taken seasonally in Darsūniškis (1998–2000) and Barevičiai (2000) are presented in Table 13. Sediment cores in Barevičiai in winter 2000 were not accessible

owing to a very thin ice cover. Sediment samples were taken in Darsūniškis and Barevičiai from the depth range 4–5 m and 6–11 m, respectively.

Uniform-vertical profiles of ^{137}Cs activity concentrations in sediment cores show them to be well mixed and homogeneous, as it was suggested earlier. Annual means of ^{137}Cs activity concentrations in sediments show them to decrease with time from $55.4 \text{ Bq}\cdot\text{kg}^{-1}$ in 1998 up to $50.2 \text{ Bq}\cdot\text{kg}^{-1}$ in 2000. This value in Barevičiai in 2000 was measured higher (~10%) than the Darsūniškis one. It may be related on the average to smaller sediment densities in Barevičiai, Table 13. Mean values of ^{137}Cs activity volume concentrations in sediment samples varied in Darsūniškis and Barevičiai in 2000 in the range: $9.7\text{--}12.4 \text{ Bq}\cdot\text{L}^{-1}$ and $10.5\text{--}12.9 \text{ Bq}\cdot\text{L}^{-1}$, respectively. ^{40}K activity concentrations in sediments were measured in the range $330\text{--}490 \text{ Bq}\cdot\text{kg}^{-1}$ with the mean value equal to $400 \text{ Bq}\cdot\text{kg}^{-1}$.

VI. ^{137}CS VERTICAL PROFILES IN SOIL.

Two flooded meadow soil cores taken in the lower Nemunas valley were analysed for ^{137}Cs and ^{40}K vertical profiles. The first soil core was taken in spring at 300 m distance from the Nemunas riverbank near Rusnė up to the 90 cm depth. Analysis showed that clay admixtures affected the ^{137}Cs vertical diffusion in this sample. The vertical profile of ^{40}K concentrations was peaked at the 18–26 cm depth ($650 \text{ Bq}\cdot\text{kg}^{-1}$ d.w.) and the entire ^{137}Cs amount was located in the upper 13 cm soil layer. The maximum ^{137}Cs concentration (~ $20 \text{ Bq}\cdot\text{kg}^{-1}$ d.w.) was distributed in the upper part of this profile (1–4 cm depth). The ^{137}Cs concentration in the water sample taken from the field canal close to the soil core sampling site was equal to $2.2 \text{ Bq}\cdot\text{m}^{-3}$ ($1.6 \text{ Bq}\cdot\text{m}^{-3}$ – in soluble form). The second soil core was taken in summer 1998 up to the 1.2 m depth at the distance of 3.8 km from the Nemunas river along the Rusnė – Šilutė road close to the field canal crossing the road. ^{137}Cs concentrations in water samples taken from this field canal in summer and autumn were equal to $14.9 \text{ Bq}\cdot\text{m}^{-3}$ ($14.0 \text{ Bq}\cdot\text{m}^{-3}$ – in soluble form) and to $6.9 \text{ Bq}\cdot\text{m}^{-3}$ ($6.1 \text{ Bq}\cdot\text{m}^{-3}$ – in soluble form), respectively. The pH of the water was 8, water was of bright brown color.

Data of the ^{137}Cs and ^{40}K vertical profiles in the second soil core are shown in Table 5.

There are a number of ^{137}Cs concentration peaks in a vertical profile with the highest (~ $38 \text{ Bq}\cdot\text{kg}^{-1}$ d.w.) at the 20–22 cm depth. Below this depth, ^{137}Cs concentrations are almost monotonously decreasing with the sharp decline below the 34 cm depth. With the exception of some deeper layers, ^{137}Cs concentrations were below the detection limit (~ $0.7 \text{ Bq}\cdot\text{kg}^{-1}$ d.w.). Long term measurements showed that ^{137}Cs concentrations at the soil core bottom were not zero and were equal to about $0.6 \text{ Bq}\cdot\text{kg}^{-1}$ d.w. The total ^{137}Cs load of this soil core was evaluated to be equal to about $4.4\cdot 10^9 \text{ Bq}\cdot\text{km}^{-2}$, which is typical of the ^{137}Cs loads of this region.

The ^{40}K concentration vertical profile shows the main part of ^{40}K to be located in the upper 20 cm layer of the soil core with the maximum values at the surface (~ $330 \text{ Bq}\cdot\text{kg}^{-1}$ d.w.).

High ^{137}Cs concentrations (especially in the dissolved form) in the field canal water of bright brown colour during warm seasons show that self-cleaning of the flooded meadow soils from ^{137}Cs is taking place due to the dilution in the water under slightly alkaline conditions (pH ~8) of the humic acid associated with ^{137}Cs . The presence of these organic acids in soil strengthens the ^{137}Cs vertical migration up to the surface water level.

CONCLUSIONS

- I. Data of a rather rough comparison of the ^{137}Cs annual flux balance in the Nemunas and Neris river water in 1998–2000 have shown that the main trend is the decrease in the ^{137}Cs annual inflow from Byelorussia with time (1996 - 3.3 Ci/year, 1998 - 1.2 Ci/year, 1999 - 1.3 Ci/year, 2000 - 0.6 Ci/year). The ^{137}Cs accumulation barrier zone of the Kaunas man-made basin from 1999 became an important source of ^{137}Cs in the river water. Investigations show that the period of the study (1998–2000) was transitional when processes of the ^{137}Cs accumulation in the Nemunas – Neris water system dominating after the Chernobyl NPP accident changed into ^{137}Cs self-cleaning ones.
- II. Formation of ^{137}Cs concentration as well as physico-chemical forms of this nuclide in the water column above the river accumulation zone is strongly affected by processes of the ^{137}Cs exchange at the bottom water-sediment interface.
- III. Seasonal data on ^{137}Cs concentrations in freshwater supplies and the well showed the ^{137}Cs penetration into the drinking water to be significant during cold season. This effect might be related to the decay of the biologically active layer of the sand buffer.
- IV. Investigations of ^{137}Cs vertical profiles in flooded meadow soils as well as ^{137}Cs concentrations in water of field canals in the Nemunas river delta showed that self-cleaning of this region soils from ^{137}Cs was due to the outflow of this nuclide associated with the organic acid dissolved in the field canal water.

SUMMARY

Data of investigations carried out in Lithuania have shown that after the Chernobyl NPP accident the Nemunas and Neris rivers became a transfer artery for radionuclides from polluted regions of Byelorussia on their way to the Baltic Sea. Thus, the objectives of the Project were: to study peculiarities of the ^{137}Cs migration and seasonal variations of its transfer by the Nemunas and Neris rivers, to evaluate the annual riverine input of this nuclide to Lithuania from Byelorussia in 1997–2000 as well as regularities of the ^{137}Cs penetration into the Kaunas and Klaipėda freshwater reservoirs and into the groundwater wells in the Nemunas river delta. Investigations were focused on seasonal variations of ^{137}Cs concentrations in the river water (total, associated with the suspended matter and in dissolved form), suspended matter concentrations, its ^{137}Cs activity and the distribution coefficient K_d of the suspended particles, vertical profiles of the ^{137}Cs specific activity and mass density in bottom sediments, determination of the character of the ^{137}Cs transfer along the Nemunas – Neris riverine system, determination of the physico-chemical forms of ^{137}Cs in the Nemunas river water and in sediments, vertical distribution of radionuclides in flooded meadow soils in the Nemunas river delta.

For the evaluation of the ^{137}Cs concentration in dissolved form, the water filtrate was treated radiochemically using the ferrocyanide precipitation method. The SILENA as well as ORTEC γ -spectrometric systems with the HPGe detectors for radionuclide analysis of water samples and for the determination of ^{137}Cs physico-chemical forms in sediments and water were used (the detection limit (d.l.) – 0.1 Bq·m⁻³). A γ -spectrometer with the Ge(Li) semiconductor detector was used for the ^{137}Cs nuclide analysis of sediments and soil ((d.l.) – 0.7 Bq·kg⁻¹).

Peculiarities of the ^{137}Cs migration in the Nemunas – Neris water system in Lithuania were studied during 1998–2000. Rough evaluations show that the accumulated fraction of ^{137}Cs inflow through the border with Byelorussia decreased from 33 % in 1996 up to 14 % in 1998. Processes of the water system self-cleaning from ^{137}Cs established in 1999 when the ^{137}Cs outflowing flux fraction due to

the system self-cleaning amounted almost to 40 % of the inflowing one. Processes of the ^{137}Cs transfer from Byelorussia in 2000 were significantly weaker than those during preceding years and the ^{137}Cs inflow amounted only to one sixth of the 1996 one. During warm seasons, ^{137}Cs soluble forms in the river water as well as exchangeable fractions of its concentration in the sediment surface layer of the accumulation zone are consumed during the phytoplankton bloom. Uniform-vertical profiles of ^{137}Cs activity concentrations in river sediment cores show them to be well mixed and homogeneous. Annual means of ^{137}Cs activity concentrations in river sediments show them to decrease with time from $55.4 \text{ Bq}\cdot\text{kg}^{-1}$ in 1998 up to $50.2 \text{ Bq}\cdot\text{kg}^{-1}$ in 2000. Vertical profiles of ^{137}Cs concentrations in sediments in the Vilhelm canal (freshwater supply) show them to grow with depth and reach maximum values at the core bottom ($140\text{--}160 \text{ Bq}\cdot\text{kg}^{-1}$).

Data of a rather rough comparison of the ^{137}Cs annual flux balance in the Nemunas and Neris river water in 1998–2000 have shown that the main trend is the decrease in the ^{137}Cs annual inflow from Byelorussia with time (1996 - $3.3 \text{ Ci}/\text{year}$, 1998 - $1.2 \text{ Ci}/\text{year}$, 1999 - $1.3 \text{ Ci}/\text{year}$, 2000 - $0.6 \text{ Ci}/\text{year}$). The ^{137}Cs accumulation barrier zone of the Kaunas man-made basin from 1999 became an important source of ^{137}Cs in the river water. Investigations show that the period of the study (1998–2000) was transitional when processes of the ^{137}Cs accumulation in the Nemunas – Neris water system dominating after the Chernobyl NPP accident changed into ^{137}Cs self-cleaning ones. Formation of ^{137}Cs concentration as well as physico-chemical forms of this nuclide in the water column above the river accumulation zone is strongly affected by processes of the ^{137}Cs exchange at the bottom water-sediment interface. Seasonal data on ^{137}Cs concentrations in freshwater supplies and the well showed the ^{137}Cs penetration into the drinking water to be significant during cold season. This effect might be related to the decay of the biologically active layer of the sand buffer. Investigations of ^{137}Cs vertical profiles in flooded meadow soils as well as ^{137}Cs concentrations in water of field canals in the Nemunas river delta showed that self-cleaning of this region soils from ^{137}Cs was due to the outflow of this nuclide associated with the organic acid dissolved in the field canal water.

ACKNOWLEDGEMENTS

Authors are grateful to the Hydrometeorology Service of the Ministry of Environment of Lithuania for the permission to use data of river debits of 1996–2000.

REFERENCES

- [1] AARKROG A., CHEN Q., DAHLGAARD H., NIELSEN S.P., TRAPEZNIKOV A., POZOLOTINA V. (1997) Evidence of ^{99}Tc in Ural river sediments. *J. Environ. Radioactivity*, 37, 2, 201–213.
- [2] AARKROG A., TRAPEZNIKOV A.V., MOLCHANOVA I.V., YUSHKOV P.I., POZOLOTINA V.N., POLIKARPOV G.G., DAHLGAARD H., NIELSEN S.P. (2000) Environmental modeling of radioactive contamination of floodplains and surlakes along the Techa and Iset rivers. *J. Environ. Radioactivity*, 49, 243–257.
- [3] BORISENKO G.S., KANDINSKY P.A., GEDEONOV L.I., IVANOVA L.M., PETROV A.A. (1986) Radiochemical determination of ^{90}Sr and ^{137}Cs in the Pacific Ocean in the boundary seas. *Radiochemistry*, 28, 519–526.
- [4] EVANS D.W., JANES J.A., CLARC R.A. (1983) Reversible ion-exchange fixation of cesium-137 leading to mobilization from reservoir sediments. *Geochim. Cosmochim. Acta*, 47, 1041–1051.

- [5] HILTON J., CAMBRAY R.S., GREEN N. (1992) Chemical fraction of radioactive cesium in airborne particles containing bomb fallout. Chernobyl Fallout and Atmospheric Material from the Sellafield Site. *J. Environ. Radioactivity*, 15, 103–111.
- [6] KARAVAJEVA E.N., MOLCHANOVA I.V., POZOLOTINA V.N. (1997) Behavior of ^{90}Sr and ^{137}Cs in floodplain soils of Techa and Iset rivers. *Atomnaja Energija*, 83, 6, 462–464 (in Russian).
- [7] KUZNECOV I.V., SCEBETKOVSKII V.M., TRUSOV A.G. (1974) Principles of water cleaning from radioactive pollution. M., Atomizdat, 360 (in Russian).
- [8] KUZNETZOV I.V., LEGIN V.K., STRUKOV V.N., NOVIKOV A.P., GORIACHENKOVA T.A., SHISHLOV A.E., SAVICKIJ J.V. (2000) Transuranic elements in floodplain sediments of the Jenisej river. *Radiochimija*, 42, 5, 470–477 (in Russian).
- [9] MARTINEZ-AGUIRRE A., GARCIA-LEON M. (1994) Identification and effects of anthropogenic emissions of U and Th on the composition of sediments in a river/estuarine system in southern Spain. *J. Environ. Radioactivity*, 23, 231–248.
- [10] MERERZKO A.I., PANKOV I.V., PASIZHNIJ A.P., VELIZHKO I.M. (1998) Radionuclides of some components of the ecosystem of the South-Bug river. *Vodnaja Radioekologija, J. Hydrobiology*, 34, 3, 92–96 (in Russian).
- [11] NOSOV A.V. (1997) Investigation of the radiological situation of the riverine system in the region of Seversk after SCHK accident in April 6, 1993. *Atomnaja Energija*, 83, 1, 49–54 (in Russian).
- [12] NOSOV A.V., MARTYNOVA A.M. (1997) Assessment of secondary contamination of the water of Jenisej river. *Atomnaja Energija*, 82, 5, 372–378 (in Russian).
- [13] TARASIUK N., ŠPIRKAUSKAITĖ N., STELINGIS K., LUJANIENĖ G. (1993) Radiation effect of the bottom sediment migration. *Meteorologija i Hidrologija*, 10, 43–46 (in Russian).
- [14] TESSIER A., CAMPHELL P.G.C., BISSON M. (1979) Sequential extraction procedure for the speciation of particulate trace metals. *Analytical Chemistry*, 51, 7, 844–851.
- [15] VOITSEKHOVITCH O., PRISTER B., NASVIT O., LOS I., BERKOVSKI V. (1996) Present concept on current water protection and remediation activities for the areas contaminated by the 1986 Chernobyl accident. *Health Physics*, 71, 1, 19–28.
- [16] VOROBIOVA M.I., DEGTEVA M.O., BURMISTROV D.S., SAFRONOVA N.G., KOZHEUROV V.P., ANSPAUGH L.R., NAPIER V.A. (1999) Review of historical monitoring data on Techa river contamination. 76, 6, 605–617.
- [17] VOROBIOVA M.I., DEGTEVA M.O. (1999) Simple model for the reconstruction of radionuclide concentrations and radiation exposures along the Techa River. *Health Physics*, 77, 2, 142–149.

MATERIALS PUBLISHED ON WORK DONE UNDER THE CONTRACT

ŠPIRKAUSKAITĖ N., TARASIUK N., LUJANIENĖ G., STELINGIS K. (1996) Possibilities of the anthropogenic radionuclide accumulation in the Kaunas reservoir – the part of the Nemunas riverine system. Proceedings of International Symposium on Ionising Radiation Protection of the Natural Environment. Stockholm, Sweden, May 20–24, 1996, 618–622.

TARASIUK N., ŠPIRKAUSKAITĖ N., LUJANIENĖ G. (1997) On the question of the cesium-137 seasonal balance in the Nemunas river. Abstracts of the Central Eastern European Conference “Ecotoxicology and Environmental Safety” (SECOTOX’97), Jurmala, Latvia, August 24–27, 1997, Jurmala, 188.

LUJANIENĖ G., LUJANAS V., TARASIUK N., ŠPIRKAUSKAITĖ N. (1998) Peculiarities of radionuclides behavior in the atmosphere and the hydrosphere. Proceedings of International Seminar on Use of Isotope Techniques in Marine Environmental Studies, Athens, Greece, 11–22 November, 1996. P. 75–88.

TARASIUK N., ŠPIRKAUSKAITĖ N. (1998) On the question of ^{137}Cs seasonal balance in the Nemunas river. J. of the Latvian Academy of Sciences, Ser. B., 52, 108–110.

ŠPIRKAUSKAITĖ N., TARASIUK N. (1998) Lithuanian water systems. Proceedings of the Scientific Conference “Problems of Lithuanian Meteorology and Hydrology on the Eve of XXI century”, Vilnius, 24–30.

TARASIUK N., ŠPIRKAUSKAITĖ N., LUJANIENĖ G. (1999) The formation of ^{137}Cs concentration in the Nemunas river accumulation zone. Environmental and Chemical Physics, Vilnius, 21, 2, 27–32.

ŠPIRKAUSKAITĖ N., TARASIUK N., LUJANIENĖ G., LUKŠIENĖ B., DRUTEIKIENĖ R. (2000) On radionuclide contamination of Lithuanian water systems. Environment of Health, Vilnius, 3, 71–76 (in Lithuanian).

MIGRATION OF RADIONUCLIDES IN SOILS AND THEIR ACCUMULATION IN SEDIMENTS OF SUPERFICIAL WATERS

ST. CHIBOWSKI, A. KOMOSA, M. RESZKA, J. SOLECKI, J. ZYGMUNT

Department of Radiochemistry and Colloid Chemistry, Maria Curie-Skłodowska University, Lublin, Poland

Abstract

Radionuclide concentration of natural (^{40}K and isotopes of uranium and thorium series) and anthropogenic origin (^{137}Cs and plutonium isotopes) was determined in samples of soil and sediment. The samples were collected in 53 places chosen along the main rivers of Eastern Poland (Bug and Wieprz rivers) and an artificial waterway (Wieprz-Krzna canal). Two lakes of the Poleski National Park were also examined. In every place sediment and two soil samples (near a riverbank and about 50m away) were taken. Radioactivity measurements were performed by means of gamma (HPGe detectors, Silena equipment) and alpha spectrometry (Canberra PIPS detectors, radiochemical treatment with ^{242}Pu as a yield monitor). Samples were also characterized by granulometric fraction and organic matter content, basic cation concentration and elemental composition. It was found that concentration of natural isotopes is similar in soils and sediments, also does not vary with the depth of soil profile. Anthropogenic nuclides behave differently — their concentration in sediment is about 4-times lower than in soil from the same place down the river. In the case of artificial waterway concentration of ^{137}Cs is almost the same in soil and sediment samples. Vertical migration of radiocesium calculated using compartment model shows that the main fraction of ^{137}Cs is present in an upper soil layer. Rate of vertical migration is very slow and ranges from 0.8 to 1.9 cm/year (Chernobyl origin of radiocesium is assumed). Cumulation of ^{137}Cs in the deepest part of lakes is observed. In these places the concentration of radiocesium is about 5–8 times higher than in soil of the lake bank.

INTRODUCTION

Within the IAEA Research Project the measurements of radioactive isotope concentration in bottom sediments of the main rivers running through southeastern territory of Poland and in soils of these river valleys were performed. The rivers of interest were the Wieprz (starting point $21^{\circ}50'E$; $51^{\circ}34'N$, ending point $23^{\circ}20'E$; $50^{\circ}34'N$), the Bug (from $21^{\circ}16'E$; $52^{\circ}33'N$ to $24^{\circ}05'E$; $50^{\circ}39'N$) and an artificial waterway, the Wieprz-Krzna canal (from $22^{\circ}50'E$; $52^{\circ}00'N$ to $23^{\circ}05'E$; $51^{\circ}06'N$). Also two lakes of Poleski National Park - Piaseczno and Masluchowskie (laying in a square $22^{\circ}50'E$ - $23^{\circ}20'E$ and $51^{\circ}15'N$ - $51^{\circ}45'N$) were investigated. In a limited range (determination of heavy metal and plutonium) in sediments of three small rivers: Bystrzyca, Czechówka and Czerniejówka, running through Lublin agglomeration ($22^{\circ}33'E$; $51^{\circ}15'N$) were investigated and described in the paper [1].

The performed examinations comprised:

- (i) Determination of horizontal migration of radionuclides by analyzing of sediment and surface soil samples from preglacial river valleys. For this purpose in the sampling sites down the river a sediment sample and two soil samples (near a riverbank and at a greater distance) were collected.
- (ii) Determination of vertical migration of the radionuclides deep into the soil profile taken from selected sampling sites.

The investigation focused on the natural gamma-emitting isotopes ^{40}K , also ^{214}Bi and ^{226}Ra (from ^{238}U series), and ^{212}Bi and ^{228}Ac (from ^{232}Th series). Also the concentration of anthropogenic gamma emitting ^{134}Cs and ^{137}Cs , as well as alpha radiating ^{238}Pu and $^{239,240}\text{Pu}$ were determined. The Wieprz river was selected for the first stage of the study as its drainage basin of 10,415 km² covers the central part of the examined area. Nearly 60% of drainage area is covered by uplands, the rest by the lowland plains. The terrain differs in a thickness of Quaternary sediments (loess and sand) covering a chalk type bedrock. Lowlands, contrary to highlands, are characterized with relatively shallow level of ground water and easier penetration of rainwater into the rock base. It is connected with domination of sandy forms on the surface of the lowlands and water adsorbing loesses at highlands. [2] The different kind of the bedrock, along the Wieprz river, may have influenced the radionuclide transport from the soil to river bottom sediments. The river is 303 km long and its average waterflow, measured near the estuary equals to 37 m³/s.

The Bug river was investigated as the next one. This river is a fourth by turns of the longest rivers, flowing by the territory of Poland and the biggest one in Eastern Poland. Total length of the river is 772 km (587 km in Poland). In its upper flow the river runs by upland created by Cretaceous rock layers in the shape of elevations and depressions. On its middle run Bug river forms 363 km of the Polish-Byelorussian and the Polish-Ukrainian border. In this region the river flows by lowlands. The Bug river in its lower part changes its direction from North to Northwest and runs through lowland formed by thick layers of Pleistocene, glacial covers on different bedrock [3]. Average waterflow at estuary is 158 m³/s; total catchment area is equal to 39,420 km² (19,284 km² in Poland). Wieprz-Krzna canal, the artificial waterway of 140 km length was built in 1961 in order to control water relations on area of 1200 km² (two third of this area is composed of cultivated meadows, one third - ploughlands. The Piaseczno lake has the area of 0.85 km² and maximal depth of 38.8 m, whereas the second lake - Masluchowskie 0.27 km² and 9.4 m, respectively [4].

METHODS

Sample collection and treatment

Sampling was performed in April/May 1998 (Wieprz river), May/June 1999 (Bug river) and May/June 2000 (Wieprz-Krzna canal and lakes). Down the Wieprz river the 33 sampling sites were selected, where soil (in two points) and sediment samples from riverbed were collected. In 8 sites (16 points) soil profiles were exposed by a trench method. The whole profile (down to 40 cm) was divided in 5-cm layers and soil samples were taken. Total number of the Wieprz river samples was 127. Bug river valley samples were taken from 10 sites (surface soil and sediment in each case). Also soil profile samples were collected in these places (down to 30 cm, i.e. 6 layers). In this way 90 samples were prepared. Samples of sediment and soil profile (8 layers) of the Wieprz-Krzna canal were collected in ten sites along the waterway. There were 90 samples for gamma measurement. In the case of two lakes of Poleski National Park five sediment samples were collected across the lake and five surface soil samples from lake surrounding meadows. Collecting points were placed on the straight line crossing the lake in Northwest direction and running by its deeper part. Figure 1 presents location of sample collecting points on the area of Poland.

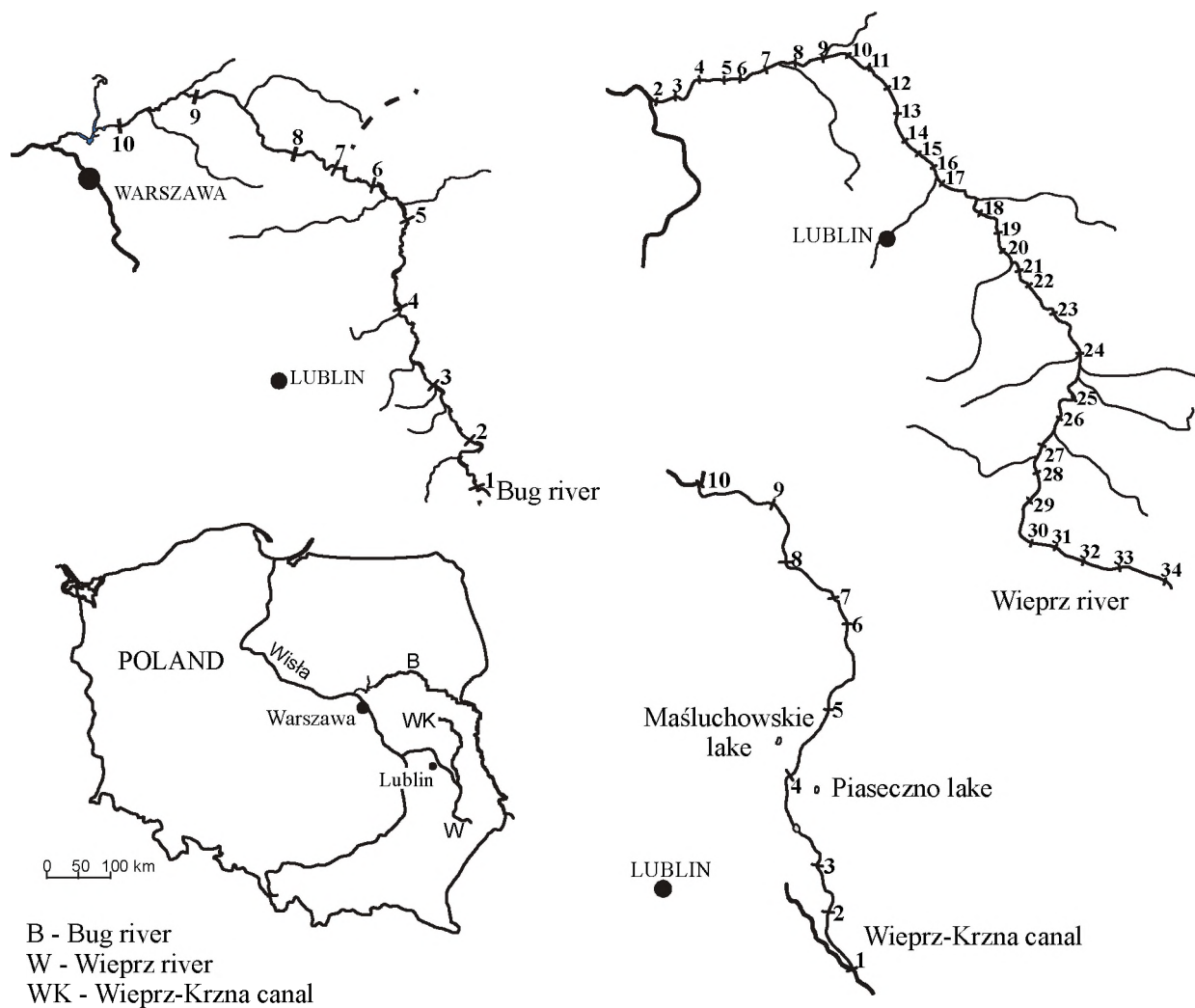

Figure 1. Location of sample collecting points.

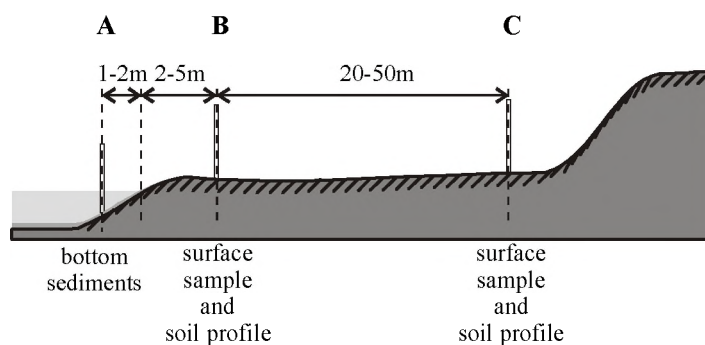

Figure 2. Diagrammatic perpendicular intersection of a riverbed with valley showing a localization of the sampling points "A", "B" and "C".

The surface soil samples were collected with a corer of 8.3-cm diameter, 5 cm high; 6 cores were taken from one point in a circle of 1-m radius and one sample in the center of the circle, and treated as a one sample. In preglacial river valley the first group of samples were taken 2–5 m from the riverbank (marked as "B") and the second 20–50 cm from the river (marked as "C").

The shape of the terrain and its accessibility determined a proper distance of the sampling points from the riverbank. In each sampling site the bottom sediment was taken, 1–2 m from the riverbank (marked as "A"). The applied sampler enabled to pick up the 10-cm core of the sediment. Usually 5 cores were collected and treated as a one sample. Figure 2 presents a diagrammatic perpendicular intersection of a riverbed with valley and localization of the sampling points "A", "B" and "C".

Figure 3 shows localization of the sampling points of sediment and surface soil from the lakes. Collected samples were air-dried, ground and sieved (<1 mm) then were successively packed to 0.5 dm³ standard Marinelli beakers, closed, weighted and kept at least fortnight to achieve equilibrium of ²²⁶Ra and its decay products then their gamma radioactivity was measured. Selected samples were submitted to a determination of the concentration of alpha-emitting plutonium isotopes (²³⁸Pu and ^{239,240}Pu) by means of alpha spectrometry preceded by a proper radioanalytical method for isotope separation.

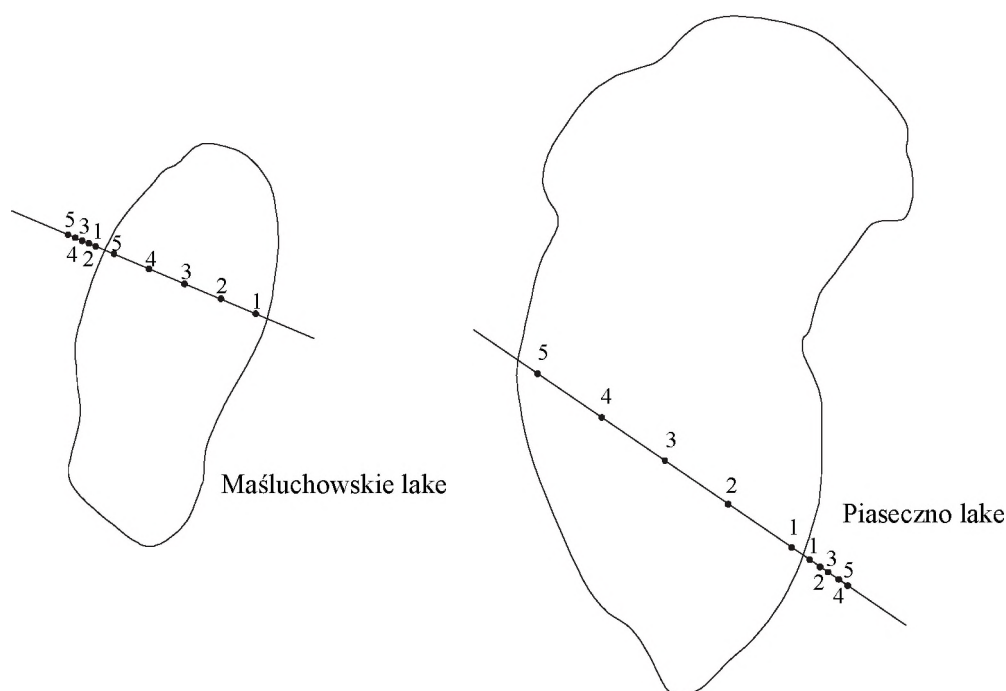

Figure 3. Localization of the sampling points across the lakes.

Gamma spectrometry

The gamma measurements were performed with the SILENA (Italy) gamma-spectrometer, equipped with the IGC 13 HPGe detector of 70-cm³ volume and relative efficiency of 13.5%. The FWHM resolution at energy 1.33 MeV was 1.70 keV, and at 122 keV 0.74 keV. The SILGAMMA/EMCA analysis package with SIMCAS II (version 4.11) data acquisition system was used to perform qualitative and quantitative analysis of samples. The measuring time was usually 300 min. On the basis of a blank sample measurement the minimum detectable amount (MDA) of ¹³⁷Cs calculated according to Currie equation, equals to about 0.37 Bq/kg [5].

Alpha spectrometry

Alpha activity of plutonium isotopes was measured (usually during 8,500÷10,000 min) using two Canberra Alpha Spectrometers, model 7401 with a System 100 MCA (1024 channels), together with the software S100 and ASP. Partially Depleted PIPS detectors: A300-19-100AM and A300-17-AM were used. The measuring efficiency of our detectors was $35 \pm 3 \%$ (0.5-cm distance between the detector and a source). The purity of the standard ^{242}Pu solution (AEA Fuel Services, U.K.) used as a radiochemical yield monitor was $\leq 0.1\%$ of ^{238}Pu and ^{241}Am , and $\leq 0.01\%$ of $^{239,240}\text{Pu}$ as certified by the producer. A verified purity was equal to 0.05% of ^{238}Pu and ^{241}Am , and 0.02% of $^{239,240}\text{Pu}$. The tracer solution prepared from the standard had a specific radioactivity of 0.73 Bq/g. Background values measured with a blank source in the $^{239,240}\text{Pu}$ peak region were about 0.012 cpm and 0.004 cpm (of the first and the second detector, respectively), and in the ^{238}Pu peak region 0.002 cpm and 0.0005 cpm (respectively). The MDA value of plutonium isotopes, calculated according to Boecker et al. [6], amounted to 0.004 and 0.015 Bq/kg for ^{238}Pu and $^{239,240}\text{Pu}$, respectively. The radiochemical procedure for Pu separation consists of dry ashing, leaching in hydrochloric acid, co-precipitation with metal hydroxide next with calcium oxalate, dry ashing of the precipitate and co-precipitation of plutonium with iron hydroxide. Further separation of plutonium isotopes was performed by means of an anion exchanger Dowex 1 x 8, using 8M HNO_3 solution, next 11M HCl and then 11M HCl with ammonium iodide for Pu stripping. The source for alpha spectrometry was prepared by electrodeposition of the isotopes on a stainless steel from ammonium oxalate / HCl solution. The details of the procedure were presented elsewhere [7].

The calculation of radiocaesium migration rate from gamma spectrometric results

Basing on gamma spectrometric data of the specific activity (Bq/kg) of ^{137}Cs and ^{134}Cs in soil profile samples, the radiocaesium deposition per 1 cm of depth was calculated. Such presentation of ^{137}Cs and ^{134}Cs activities in subsequent soil profile layers, expressed in Bq/m²/cm eliminates the influence of the soil density and thickness of the soil layer. The activity was calculated from the following equation:

$$A_s = \frac{A \cdot m}{s \cdot l}$$

where:

- A_s – activity of ^{137}Cs or ^{134}Cs [Bq/m²/cm]
- A – activity of ^{137}Cs or ^{134}Cs [Bq/kg]
- m – total weight of the sample [kg]
- s – cross-sectional area of the profile [m²]
- l – thickness of the profile layer [cm]

The content of Chernobyl derived radiocaesium was calculated from ^{134}Cs content in the analyzed sample. Because of its short half-life (2.06 years), ^{134}Cs present in the soils was assumed to originate only from the Chernobyl fallout. The $^{134}\text{Cs}/^{137}\text{Cs}$ ratio in the first days after the accident was equal to 0.528 [8]. Taking into account the law of radioactive decay and $T_{1/2}$ values, the estimated ratio of two radionuclides at the time of sampling was 0.01228. Consequently, the activity of ^{137}Cs of the Chernobyl origin was calculated as follows:

$$A_{Cs-137} = \frac{A_{Cs-134}}{0.01228}$$

Total activity of ^{137}Cs in the soil per 1m^2 was calculated by summing activities in consecutive layers:

$$A_T = \sum_{n=1}^{n=z} A_n l_n$$

where:

- A_n – cesium radioactivity in n -th layer [$\text{Bq}/\text{m}^2/\text{cm}$]
- l_n – thickness of n -th layer [cm]
- A_T – total cesium radioactivity in soil profile [Bq/m^2]
- z – number of layers

Initially, to calculate a vertical migration rate of ^{137}Cs , a half-thickness soil layer model was used. This model was the simple one and the obtained result was only a rough estimation. Compartment model was applied as the next one, in which the scanning layers were taken as the compartments of known cesium activity and the rate of radionuclide transport was characterized by a corresponding residence half time within each layer [9,10]. The transfer of the activity A_i [Bq/m^2] of a radionuclide in each compartment i in a small time interval Δt [days] is expressed by the equation:

$$\frac{\Delta A_i}{\Delta t} = k_{i-1} A_{i-1} - k_i A_i - k_r A_i$$

where the dimension of the compartment corresponds to the scanning layer (of 5-cm thickness), k_i [days] is the fractional transfer rate from compartment i to compartment $i+1$, k_r is the radioactive decay constant [days^{-1}]. The solution of the above equation depends on the type of function, which describes radioactive fallout. In our calculations it was assumed that whole ^{137}Cs came from Chernobyl deposition, which took place during the one day. The assumption of Chernobyl origin of radiocesium is supported by previous investigations that reveal 80% of the total cesium found in East Poland in soil profiles as coming from Chernobyl [11]. According to above assumptions the equation may be expressed as follows:

$$A_i = I \sum_{j=1}^i C_{i,j} \cdot \exp([k_j + k_r] \cdot t)$$

where:

- I – radiocesium deposition, equal to ^{137}Cs inventory in the whole profile at a starting time [Bq/m^2],
- t – time elapsed from the deposition to the measurement [year].

Factor $C_{j,i}$ may be express as follows:

$$C_{j,i} = \frac{\prod_{k=1}^{i-1} k_k}{\prod_{k=1}^i [k_k - k_j]} \{k \neq j\}$$

The mean residence half time [years] in the layer i may be calculated from the obtained values of k as follows:

$$\tau_i = \ln 2 / k_{i, j+1}$$

and the migration rate [cm/year] from the compartment i of the thickness Δx_i [cm], to the successive layer $i+1$ as:

$$v_i = \Delta x_i / \tau_i$$

RESULTS AND DISCUSSION

Physicochemical characteristic of the soil and sediment samples

Several physicochemical parameters such as: granulometric fraction content (measured by Casagrande's areometric method), concentration of exchangeable cations K^+ , Na^+ , Ca^{2+} , Mg^{2+} (by means of ammonium acetate leaching followed by AAS measurement) and organic matter content (as a weight loss during calcination at 450°C) were determined in analyzed samples. Results are presented in Table 1. In the table letter "W", "B" and "K" of sample code denotes the samples of Wieprz river, Bug river and Wieprz-Krzna canal, respectively. It is seen that average content of sand fraction (1–0.1 mm) in all samples is similar and ranges from 54% to 59%. The content of silt (<0.02 mm) and clay (<0.002 mm) fraction is the highest in the Wieprz river samples (16% and 5%). The Wieprz-Krzna canal and Bug river samples reveal 8.5% and 2.5% of mean silt fraction concentration and 1.8% and 2.5% of clay fraction, respectively. It can be seen also that results of exchangeable cation concentration in the Bug river and Wieprz -Krzna canal samples are very similar. It is worthy of notice that the samples of the Wieprz River show smaller concentration of sodium ions and about 10-times lower calcium content than samples of other analyzed waterways. Therefore, the sum of basic cations is also about 10-times lower. The sample characteristics were supplemented (in the case of Bug and Wieprz River) by elemental composition determination. The ED-XRF analytical method with radioactive excitation sources was used. In Table 2 concentration of several major (K, Ca, Fe and Ti) and trace elements (Mn, Cu, Zn, Sr and Pb) is presented.

Text cont. on pg. 100.

TABLE 1. Granulometric composition and some chemical properties of collected samples

Sample code	Size fraction %				OM	Exchangeable cations, eq/100g of soil				
	1-0.1 mm	0.1-0.02 mm	<0.02 mm	<0.002 mm		Ca ²⁺	Mg ²⁺	K ⁺	Na ⁺	Sum of basic cations
Wieprz river										
W2B	78	16	6	3	3.5	2.62	0.64	0.11	0.05	3.42
W7B	75	14	11	5	1.8	2.77	0.25	0.05	0.03	3.10
W11B	69	22	9	3	3.4	2.69	0.66	0.34	0.01	3.70
W18B	10	53	37	9	10.9	2.95	0.89	0.18	0.14	4.16
W22B	54	28	18	5	3.9	2.85	0.70	0.19	0.03	3.77
W27B	31	48	21	7	2.8	2.81	0.72	0.28	0.03	3.84
W33B	74	18	8	2	7.7	2.77	0.49	0.08	0.06	3.40
W2C	75	17	8	3	3.2	2.68	0.68	0.10	0.04	3.50
W7C	59	27	14	4	5.7	2.81	0.57	0.09	0.06	3.53
W11C	61	28	11	4	5.3	2.73	0.74	0.36	0.03	3.86
W18C	37	28	35	15	6.2	2.90	0.61	0.89	0.02	4.42
W22C	52	28	20	7	3.8	2.85	0.74	0.20	0.01	3.80
W27C	32	47	21	6	4.2	2.84	0.78	0.43	0.03	4.08
W33C	86	10	4	1	1.2	2.57	0.49	0.21	0.01	3.28
Bug river										
B1A	13	74	13	2	2.7	35.79	0.501	0.10	0.03	36.43
B2A	6	70	24	3	4.5	23.67	0.95	0.18	0.13	24.94
B3A	62	26	12	3	1.6	39.78	0.72	0.16	0.15	40.82
B4A	73	21	6	3	1.3	29.45	0.64	0.15	0.17	30.42
B5A	40	47	13	2	6.5	49.40	2.01	0.34	0.26	52.02
B6A	81	14	5	3	1.0	34.89	0.74	0.15	0.17	35.96
B7A	80	15	5	3	0.8	29.85	1.41	0.32	0.26	31.85
B8A	74	21	5	3	1.3	48.00	1.01	0.20	0.01	49.23
B9A	89	7	4	2	0.9	50.37	1.23	0.22	0.31	52.15
B10A	82	11	7	3	1.1	24.26	0.56	0.11	0.17	25.11
B1B	15	66	19	3	11.4	60.72	1.02	0.31	0.28	62.35
B2B	20	70	10	2	6.5	56.38	0.77	0.18	0.20	57.54
B3B	17	71	12	2	7.3	56.09	0.87	0.22	0.23	57.42
B4B	84	12	4	2	9.3	60.08	0.62	0.14	0.25	61.11
B5B	32	46	22	2	4.8	15.36	0.66	0.10	0.18	16.31
B6B	86	10	4	2	1.7	3.77	0.18	0.07	0.17	4.20
B7B	85	11	4	2	1.2	3.77	0.28	0.10	0.16	4.32
B8B	43	52	5	3	4.7	3.82	0.17	0.07	0.16	4.22
B9B	96	2	2	2	3.9	8.50	0.40	0.11	0.19	9.21
B10B	93	3	4	3	3.3	47.18	0.31	0.10	0.20	47.8
Wieprz-Krzna canal										
K1A	83	10	7	2	2.8	93.02	0.85	0.23	0.22	94.34
K2A	87	10	3	1	12.1	98.50	0.85	0.28	0.22	99.87
K3A	92	4	4	2	3.7	56.61	0.55	0.10	0.17	57.44
K4A	20	57	23	2	4.1	21.75	0.31	0.04	0.14	22.25
K5A	36	46	18	3	14.2	67.33	1.05	0.17	0.18	68.75
K6A	68	24	8	1	3.9	14.94	0.19	0.05	0.11	15.31
K7A	32	53	15	2	0.5	11.72	0.25	0.09	0.15	12.22
K8A	31	51	18	1	6.7	27.28	0.44	0.18	0.14	28.05
K9A	27	54	19	2	2.4	23.52	0.91	0.49	0.12	25.05
K10A	65	30	5	2	3.8	67.58	0.37	0.09	0.12	68.17
K1B	14	71	15	2	9.1	18.48	1.53	0.41	0.12	20.56
K2B	80	15	5	1	8.6	24.66	1.04	0.20	0.12	26.03
K3B	75	19	6	2	2.9	4.66	0.29	0.19	0.14	5.29
K4B	61	30	9	2	6.3	6.11	0.69	0.42	0.13	7.36
K5B	61	31	8	2	5.8	27.18	0.65	0.31	0.14	28.29
K6B	49	38	13	2	5.9	9.23	0.58	0.38	0.19	10.39
K7B	53	35	12	2	12.4	46.66	1.04	0.38	0.21	48.30
K8B	65	28	7	1	7.7	34.84	0.74	0.32	0.18	36.09
K9B	78	15	7	2	8.3	27.18	0.39	0.25	0.14	27.98
K10B	77	19	4	1	16.2	25.79	1.49	0.16	0.25	27.71

TABLE 2. Concentration of major and selected trace elements in sediment ("A") and soil samples ("B" and "C") of the Wieprz and Bug rivers, as determined by ED-XRF method.

Sample code	[%]				[ppm]				
	K	Ca	Fe	Ti	Mn	Cu	Zn	Sr	Pb
Wieprz river									
W2B	0.81	0.29	0.60	0.13	247	21	31	39	27
W11B	0.81	0.44	0.66	0.12	262	36	42	46	33
W22B	1.0	0.71	0.89	0.13	341	25	27	69	28
W27B	1.43	1.12	1.14	0.25	432	24	51	96	34
Bug river									
B1A	1.50	5.39	1.43	0.05	524	33	36	231	28
B2A	1.34	5.91	1.29	0.26	708	35	53	251	33
B3A	1.02	2.36	0.77	0.15	277	26	30	113	24
B4A	0.92	1.77	0.48	0.14	179	28	22	61	22
B5A	1.22	1.80	0.92	0.91	281	30	31	125	25
B6A	0.89	0.49	0.33	0.10	121	30	18	43	22
B7A	0.98	0.48	0.38	0.13	140	30	15	44	16
B8A	0.81	0.77	0.42	0.13	234	26	16	56	19
B9A	0.72	0.59	0.44	0.07	202	32	19	51	20
B10A	0.90	1.70	0.38	0.08	243	26	12	77	25
B1B	1.63	8.38	1.82	0.30	1093	47	78	346	57
B2B	1.65	4.20	1.15	0.29	430	33	42	166	34
B3B	1.58	4.73	1.54	0.27	812	37	51	212	32
B4B	0.80	0.39	0.41	0.10	165	29	38	38	27
B5B	1.35	0.54	0.78	0.20	224	22	29	66	22
B6B	0.65	0.17	0.28	0.06	127	26	22	28	23
B7B	0.65	0.19	0.29	0.07	95	20	23	34	20
B8B	1.17	0.64	0.76	0.26	315	32	24	60	26
B9B	0.86	0.31	0.20	0.05	129	29	14	31	16
B10B	0.85	0.32	0.33	0.07	157	26	19	37	19
B1C	1.43	5.22	1.26	0.25	309	27	45	182	30
B2C	0.79	2.71	0.62	0.11	208	22	21	117	20
B3C	1.21	1.10	1.50	0.19	419	32	44	78	26
B4C	0.71	0.25	0.25	0.06	68	25	25	25	17
B5C	1.04	0.48	0.72	0.21	182	29	14	59	24
B6C	0.65	0.18	0.30	0.08	119	32	14	26	18
B7C	0.99	0.49	0.61	0.18	228	32	18	53	20
B8C	0.61	0.12	0.19	0.05	93	22	14	27	17
B9C	0.80	0.15	0.48	0.08	131	21	14	34	21
B10C	0.85	0.22	0.19	0.04	52	27	20	37	23

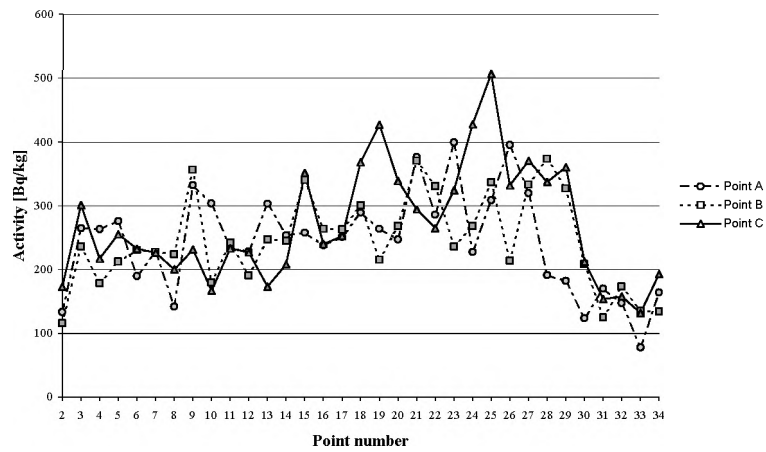

a)

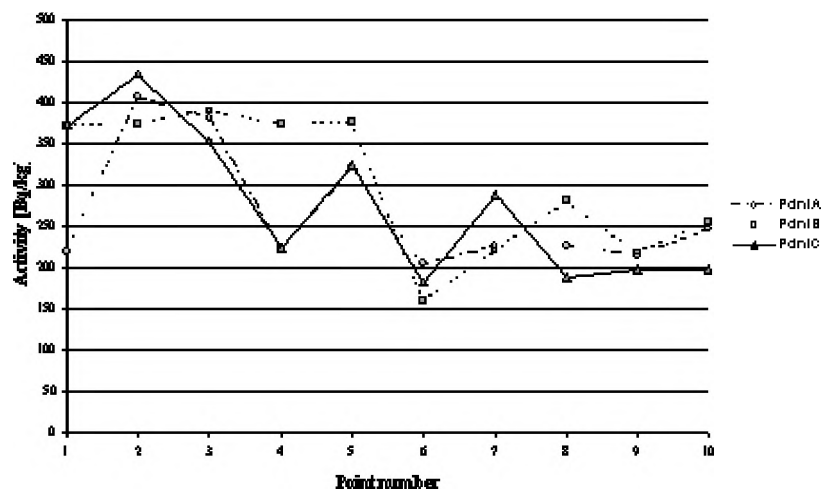

b)

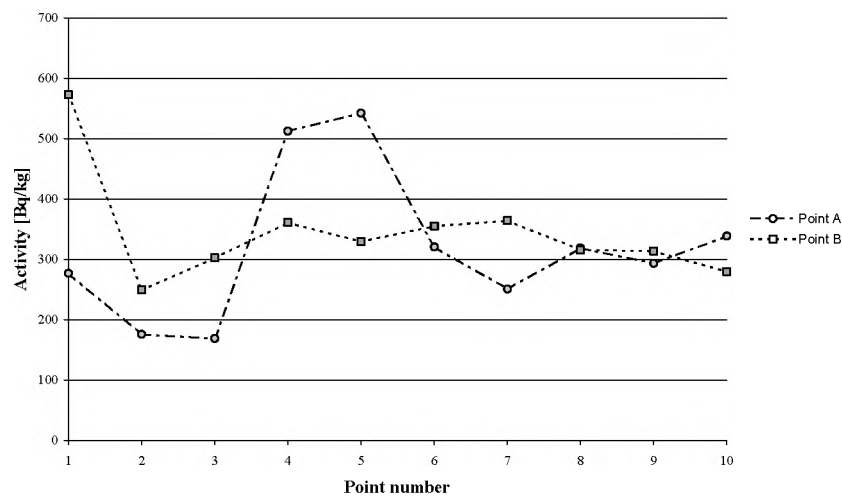

c)

Figure 4. Radioactivity of ^{40}K versus number of collecting place. a) Wieprz river; b) Bug river; c) Wieprz-Krzna canal.

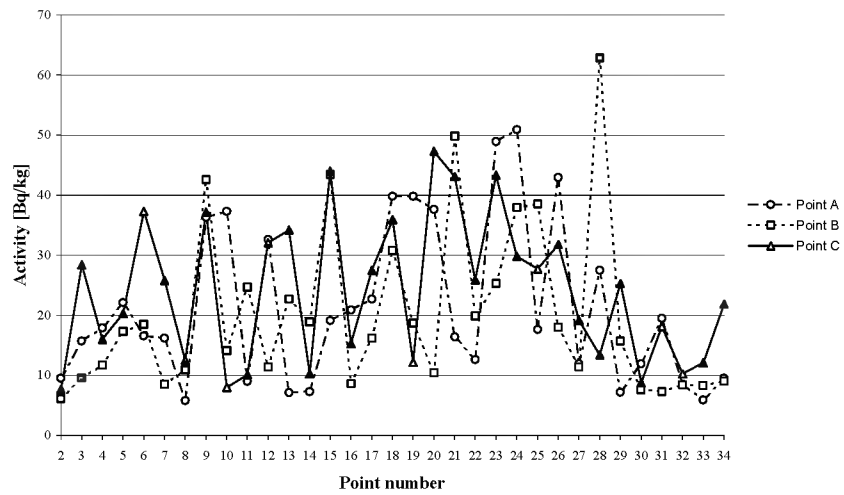

a)

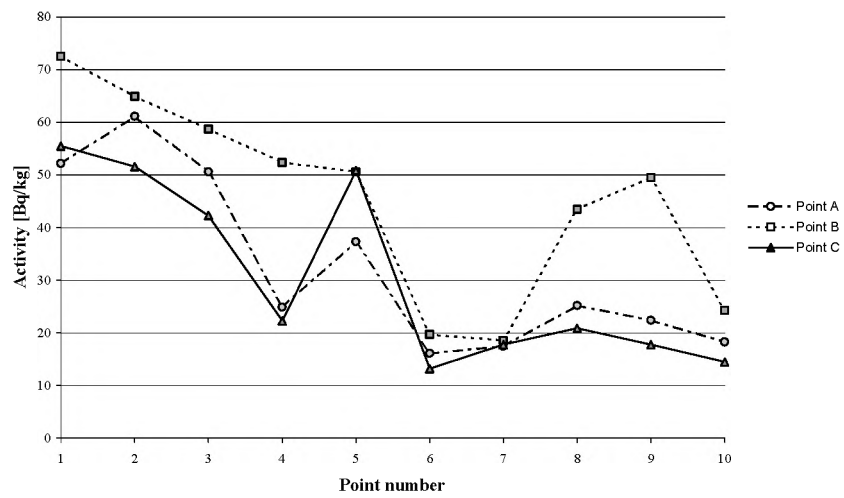

b)

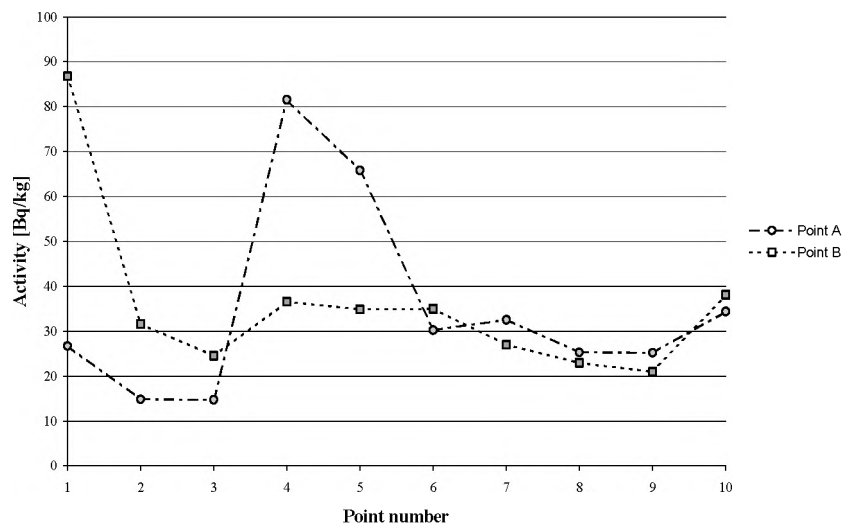

c)

Figure 5. Radioactivity of ^{226}Ra versus number of collecting place. a) Wieprz river; b) Bug river; c) Wieprz-Krzna canal.

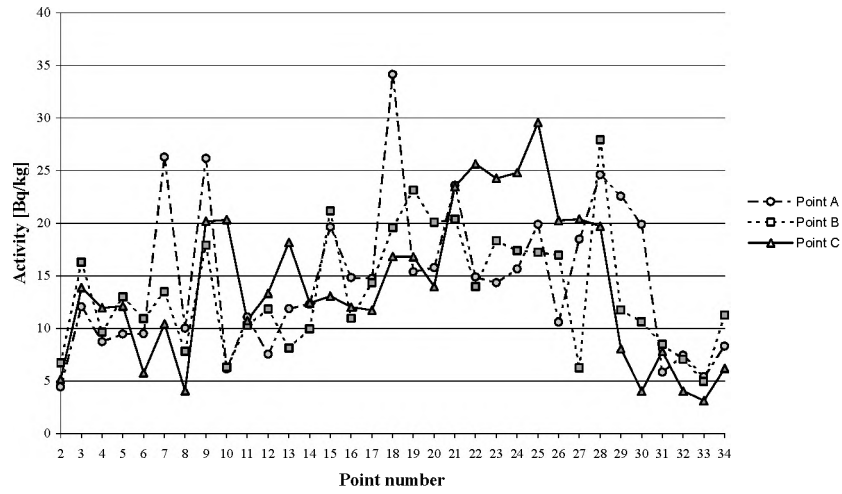

a)

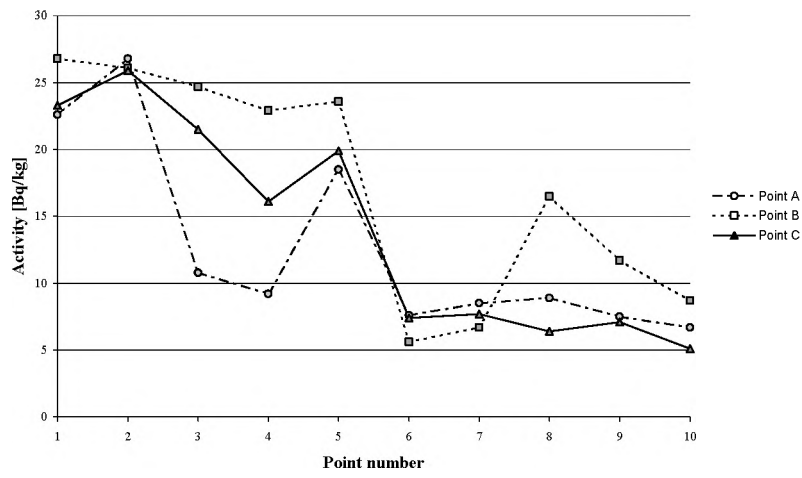

b)

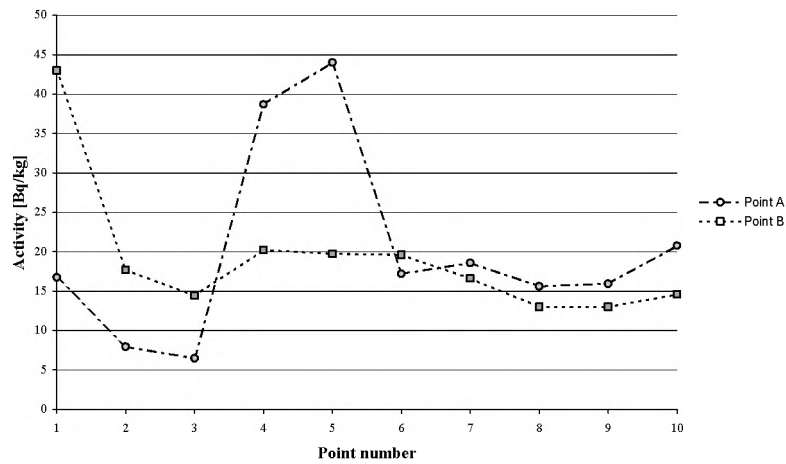

c)

Figure 6. Radioactivity of ^{228}Ac versus number of collecting place. a) Wieprz river; b) Bug river; c) Wieprz-Krzna canal.

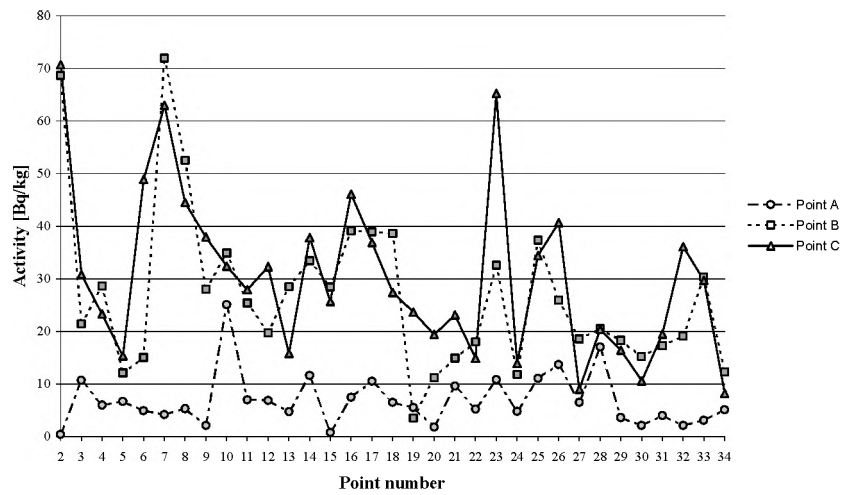

a)

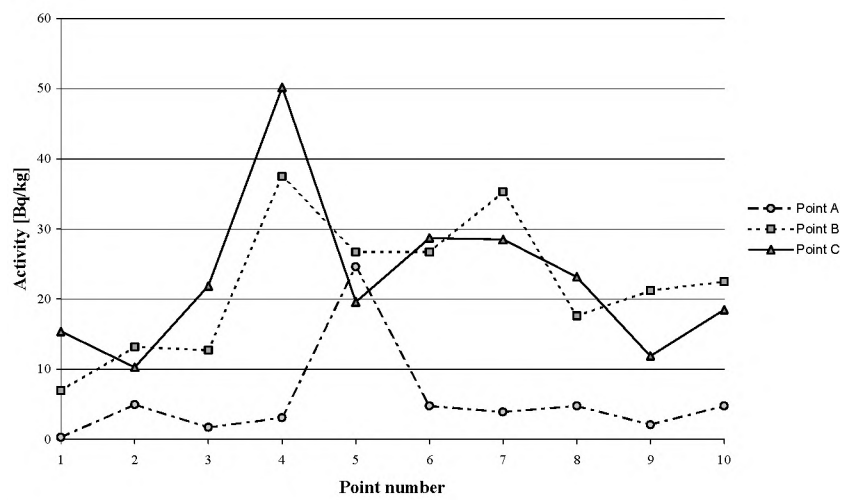

b)

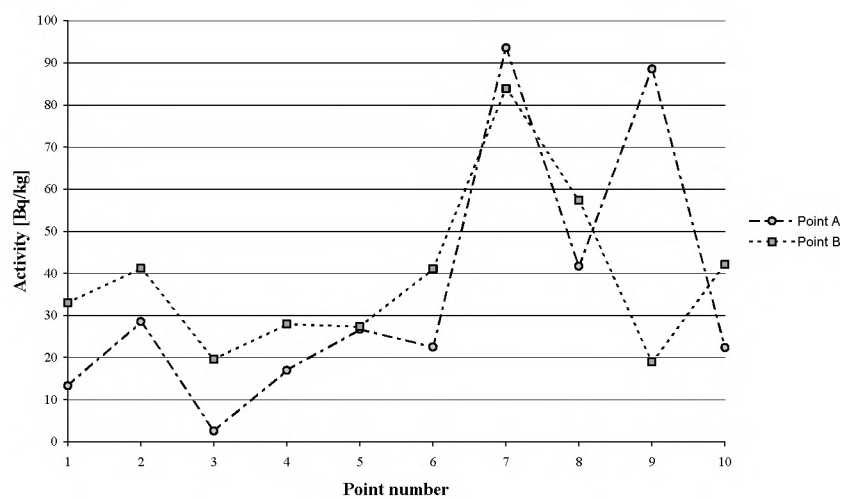

c)

Figure 7. Radioactivity of ^{137}Cs versus number of collecting place. a) Wieprz river; b) Bug river; c) Wieprz-Krzna canal.

Horizontal migration of gamma radiation emitting nuclides

In order to estimate the horizontal migration of radionuclides from soil to bottom sediment of the investigated waterways a determination of gamma emitting nuclides was performed. In every sample (marked as "A", "B" and "C", as mentioned above) the concentration of natural decay series nuclides and radiocesium was measured spectrometrically. For simplification, only a few isotopes are presented in Figures 4–7 in the form of the relationship: specific radioactivity [Bq/kg] of the nuclide versus number of collecting place. The following nuclides are listed: ^{40}K , ^{226}Ra (^{238}U series), ^{228}Ac (^{232}Th series) and ^{137}Cs , respectively in Figures 4, 5, 6 and 7. In each Figure three drawings are placed, concerned the results of Wieprz river (A), Bug river (B) and the Wieprz-Krzna canal (C).

Measured concentration of natural series radionuclides and ^{40}K , which are shown on Fig. 4–6 (and also other nuclides, not presented on drawings) reveals irregular changes going from one collecting point to another. It is not possible to find any significant tendency in these changes — a mean value of concentration is similar. There are also no differences in specific nuclide radioactivity between points "A", "B" and "C". In other words — a distribution of natural radionuclides in soil and sediment is uniform.

In the case of natural waterways, the Wieprz and Bug rivers, an artificial radionuclide — ^{137}Cs — behaves in a different manner. Though its concentration changes irregularly, the radioactivity in sediment ("A") is definitively lower (about 4-times) than in the soil sample of the same point ("B" or "C"). There are three possible explanation of this behaviour. First one is such, that cesium isotope is adsorbed very strongly on soil species, what hinders its horizontal transport with water towards river sediment. Another one is such, that cesium in soil is bound to the easily available form. Thus, it can be readily transferred from sediment to water, as ions or complexes. Beside these two explanations, the running water acts as transporting medium. Small sized particles of clay, which contain adsorbed radiocesium can be suspended in water and transported at a long distance. The determination of radiocesium concentration in water could decide which mechanism is the most probable one. Unfortunately, due to difficulties in water sample preparation such measurements were not performed.

On the other hand, radiocesium activity in soil of the Wieprz-Krzna canal changes in the same way as in sediment, going from one point to another, down the waterway. Differently, in comparison with the other examined waterways, the average value of ^{137}Cs concentration in soil and sediment is very similar. This is probably connected with a very low waterflow in the Wieprz-Krzna canal. The fact that this waterway is an artificial one, built in 1961 (as it is mentioned above) is not meaningless. Comparison with the granulometric data (Table 1) allows to notice that soils and sediments of the Wieprz-Krzna canal have the lowest concentration of the clay fraction. This may explain the low migration rate of radiocesium [11].

Results of investigation of natural radionuclides and radiocesium in samples of soil and sediment taken across the lakes of Poleski National Park are presented in Table 3.

TABLE 3. Average concentration of selected natural radionuclides and radiocesium in soil (the mean value of samples collected in five points laying along a straight line, which run about 30 m from the lake bank) and distribution of these nuclides in sediments taken across the lake

Sample	[Bq/kg]			
	⁴⁰ K	²²⁸ Th	²²⁶ Ra	¹³⁷ Cs
Maśluchowskie lake				
soil	213	35.5	14.7	31
Maśluchowskie lake				
sediment 1	141	11.2	2.7	12
sediment 2	321	30.7	17.9	28
sediment 3	474	107.6	32.2	169
sediment 4	469	9.2	26.4	138
sediment 5	154	14.9	1.1	10
Piaseczno lake				
soil	202	22	10.7	38
Piaseczno lake				
sediment 1	138	8.5	1.2	2
sediment 2	319	52	7.4	208
sediment 3	335	47	15.3	317
sediment 4	364	61	21.7	187
sediment 5	101	14	4.7	0.4

The concentrations of ⁴⁰K, ²²⁸Th and ²²⁶Ra as the representatives of natural radionuclides and radiocesium are shown in Table 3. It can be seen that natural isotope concentration does not differ much from its average concentration in other samples. However, a certain increase in concentration is observed in the deepest part of the lake. This is likely connected with cumulation of radionuclides as a result of biota activity. In the case of radiocesium its cumulation in deep water sediment is clearly visible. The ¹³⁷Cs concentration in the deepest part of the lake is 5-times (the Maśluchowskie lake) and 8-times (the Piaseczno lake) higher than in soil. This observation suggests that fallout radiocesium is transported from soil towards sediment in the slightly soluble form, firmly bound with soil species.

Horizontal migration of plutonium isotopes

The results of ^{239,240}Pu and ²³⁸Pu determination in the Wieprz and Bug River samples are presented in Table 4 and 5. Specific activity of plutonium isotopes (in Bq/kg) as well as the MDA values and Chernobyl fraction (calculated according to Hirose equation [12]) is shown in Tables 4 and 5. Concentration of ^{239,240}Pu in soil of the Wieprz river reveals rather high variability — from 0.028 to 0.334 Bq/kg. Average concentration of these nuclides equals to 0.145 Bq/kg (sample "B") and 0.160 Bq/kg (sample "C"). In the case of the Bug River the ^{239,240}Pu specific activity of soil samples "B" varies from 0.004 to 0.419 Bq/kg (mean value 0.174 Bq/kg).

Average concentrations of ^{239,240}Pu in sediment samples of the Wieprz and Bug rivers are equal to 0.039 Bq/kg and 0.058 Bq/kg, respectively. As it is seen, concentration of plutonium in sediment samples of these two rivers is about 4-times lower than in soil, collected from the same point along the river. It is interesting to learn, that the ¹³⁷Cs concentration (as it is mentioned above) shows the same behaviour — the activity in sediment is 4-times lower than in soil.

TABLE 4. Plutonium concentration in the Wieprz River samples

Sample code	Yield [%]	[Bq/kg]	[mBq/kg]	[Bq/kg]	[mBq/kg]	[%]
		$^{239,240}\text{Pu} \pm 1\sigma$	MDA $^{239,240}\text{Pu}$	$^{238}\text{Pu} \pm 1\sigma$	MDA ^{238}Pu	$^{239,240}\text{Pu}_{\text{Chernobyl}}$
W3A	33	0.021±0.006	18	0.002±0.002	7	12
W5A	80	0.043±0.002	4	0.007±0.002	2	27
W12A	74	0.064±0.003	4	0.001±0.001	2	-
W16A	23	0.025±0.005	16	<0.007	7	-
W19A	55	0.046±0.003	6	0.003±0.001	3	5
W23A	58	0.052±0.005	11	0.002±0.002	4	-
W26A	70	0.023±0.002	9	0.001±0.001	4	1
W29A	63	0.041±0.004	11	0.002±0.001	4	2
W33A	65	0.040±0.003	5	0.002±0.001	2	2
W3B	55	0.177±0.008	6	0.007±0.002	3	0
W5B	40	0.061±0.004	7	0.003±0.001	3	2
W12B	66	0.123±0.006	8	0.003±0.001	3	-
W16B	66	0.069±0.004	8	0.001±0.001	3	-
W19B	63	0.028±0.003	8	0.003±0.001	3	15
W23B	56	0.323±0.013	7	0.012±0.002	3	-
W26B	57	0.095±0.006	6	0.007±0.002	3	7
W29B	83	0.099±0.005	5	0.007±0.001	2	7
W33B	49	0.334±0.015	8	0.011±0.002	3	-
W3C	45	0.182±0.009	11	0.011±0.002	4	4
W5C	65	0.109±0.005	8	0.006±0.001	3	3
W12C	69	0.157±0.007	8	0.001±0.001	3	-
W16C	40	0.066±0.005	8	0.005±0.001	3	8
W19C	77	0.246±0.008	4	0.023±0.002	2	12
W23C	66	0.315±0.012	11	0.010±0.002	4	-
W26C	56	0.151±0.007	10	0.010±0.002	4	6
W29C	55	0.048±0.005	11	0.007±0.002	4	23
W33C	61	0.169±0.007	9	0.009±0.002	3	3

In the Tables 4 and 5 concentration of other plutonium isotope — ^{238}Pu — is also presented. However, the activity level of this nuclide is very low, sometimes does not exceed the MDA value. Therefore, determination of this nuclide is connected with high uncertainty. This is a reason of large variation of percentage contents of the Chernobyl plutonium in analyzed samples. Average value of Chernobyl plutonium fraction in the Wieprz river samples is equal to about 8%, and in the Bug river ones — about 25%. It suggests that the Bug river valleys are more contaminated with Chernobyl fallout than these of Wieprz river.

Obtained results of plutonium concentration in the Bug river samples were attempted to correlate with the physicochemical properties (see Table 1 and 2). Among many parameters studied, such as organic matter content, concentration of exchangeable cations, major elements and granulometric fraction, a good correlation was found only between $^{239,240}\text{Pu}$ activity and organic matter content in sediment samples (correlation coefficient $R=0.9$).

TABLE 5. Plutonium concentration in the Bug river samples

Sample code	Yield [%]	[Bq/kg]	[mBq/kg]	[Bq/kg]	[mBq/kg]	[%]
		$^{239,240}\text{Pu} \pm 1\sigma$	MDA $^{239,240}\text{Pu}$	$^{238}\text{Pu} \pm 1\sigma$	MDA ^{238}Pu	$^{239,240}\text{Pu}_{\text{Chernobyl}}$
B1A	26±3	<0.017	17	0.008±0.005	7	0
B2A	25±3	0.209±0.030	27	0.008±0.006	10	0
B3A	80±8	0.006±0.002	3	0.002±0.001	1	64
B4A	57±6	0.011±0.006	9	0.004±0.002	3	70
B5A	73±7	0.193±0.013	5	0.008±0.002	2	0
B6A	65±6	0.010±0.002	3	0.002±0.001	1	35
B7A	71±7	0.004±0.004	7	0.001±0.001	3	46
B8A	75±7	0.020±0.003	4	0.007±0.002	1	67
B9A	67±7	<0.007	7	0.002±0.002	3	0
B10A	86±8	0.010±0.002	3	0.002±0.001	1	35
B1B	42±5	0.098±0.016	15	0.019±0.006	6	33
B2B	39±4	0.115±0.022	3	0.015±0.008	1	20
B3B	85±8	0.049±0.005	3	0.006±0.002	1	18
B4B	25±3	0.419±0.037	19	0.021±0.006	8	2
B5B	59±6	0.195±0.014	4	0.007±0.002	2	0
B6B	57±6	0.179±0.014	11	0.054±0.006	5	57
B7B	84±4	0.257±0.013	4	0.013±0.002	1	2
B8B	83±8	0.125±0.008	6	0.008±0.002	2	5
B9B	46±5	<0.004	4	<0.002	2	0
B10B	63±6	0.132±0.009	4	0.004±0.001	1	0

It is surprising that such correlation does not exist in the case of soil samples ($R=0.1$). Plutonium concentration in soil slightly correlates with radiocesium content in the samples ($R=0.7$). The other parameters do not show any significant correlation with plutonium concentration.

Vertical migration of gamma emitting radionuclides

Gamma spectrometric examination of the soil profile samples allowed determining of the natural radionuclide concentration and radiocesium, as well. It is obvious that natural radionuclide activity should not vary between successive layers of the profile. Therefore, their concentration in soil can be described by the mean value (averaged down to 40 cm). These values of chosen natural radionuclides — ^{40}K , ^{228}Th (or ^{228}Ac) and ^{226}Ra is presented in Table 6. Total inventory of ^{137}Cs in soil profile, as surface deposition (in Bq/m^2) is shown in Table 6. Data of the artificial nuclide — ^{137}Cs — coming from fallout, were used to calculate its vertical migration rate.

The activity of particular radionuclide of natural origin in all analyzed samples is very similar. On the other hand, radiocesium inventory ranges in a large extent: 2.1 - 13.5 kBq/m^2 (the Wieprz River), 1.6 - 9.2 kBq/m^2 (Bug river) and 4.2 - 10.1 kBq/m^2 (Wieprz-Krzna canal).

Rate of vertical migration of radiocesium, calculated with a compartment model

Compartment model, which is described above, is frequently used to calculate the migration rate of various radionuclides in soil. This model is useful because of its relative simplicity. That is because the knowledge of transport mechanism and such soil parameter as diffusion coefficients are not necessary.

TABLE 6. Average concentration of some natural radionuclides [Bq/kg] and radiocesium inventory [Bq/m²] present in soil, obtained by measuring the soil profile layers down to 40cm (sample „B” were collected near the river bank, sample „C” at the 20–50 m distance)

Sample code	[Bq/kg]			[Bq/m ²]
	⁴⁰ K	²²⁸ Th	²²⁶ Ra	¹³⁷ Cs
Wieprz river				
W2B	220	31.2	18.1	5189
W4B	200	23.2	13.8	3010
W7B	346	52.6	41.6	5816
W11B	263	36.3	23.5	2315
W18B	290	27.9	20.2	3306
W22B	311	51.2	31.1	3738
W27B	440	62.9	37.0	5583
W33B	141	18.5	10.7	3941
W2C	201	20.4	14.5	6205
W4C	287	14.4	10.9	3351
W7C	244	37.1	18.7	2297
W11C	245	24.2	22.7	2655
W18C	321	53.7	32.0	2130
W22C	355	46.7	34.0	3098
W27C	396	48.1	38.9	13520
W33C	115	21.0	10.2	2557
Bug river				
B1B	399	64.7	53.9	2885
B2B	362	54.4	55.1	5029
B3B	317	55.4	44.7	3497
B4B	322	42.9	41.7	6421
B5B	317	38.6	39.5	3891
B6B	158	16.0	16.0	4284
B7B	187	17.3	14.5	2981
B8B	295	52.6	49.8	5369
B9B	207	23.2	23.0	1775
B10B	236	26.9	21.0	3207
B1C	384	59.2	52.2	1612
B2C	412	60.4	55.8	2162
B3C	333	47.0	42.2	2278
B4C	161	16.4	18.1	3109
B5C	312	55.5	48.6	3106
B6C	161	17.9	16.8	4277
B7C	266	33.7	32.3	4132
B8C	208	25.2	20.9	5265
B9C	209	22.1	23.3	9180
B10C	193	15.6	12.9	3216
Wieprz-Krzna canal				
K1B	573	43	87	5116
K2B	249	18	32	4573
K3B	303	14	25	4229
K4B	361	20	37	5441
K5B	329	20	35	7686
K6B	355	20	35	7348
K7B	364	17	27	5429
K8B	315	13	23	9373
K9B	314	13	21	10131
K10B	280	15	38	7743

TABLE 7. The vertical migration rate of ^{137}Cs calculated by using the compartment model.

Layer [cm]	Migration rate [cm/year]														
	Wieprz river (points B and C)														
	2B	4B	7B	11B	18B	22B	27B	33B	2C	4C	11C	18C	22C	27B	33C
0-5	0.41	0.44	0.45	0.65	0.64	0.79	0.75	0.85	0.40	0.63	0.56	0.49	0.95	1.23	0.64
5-10	0.41	0.83	0.68	1.17	1.03	1.08	1.59	1.37	1.10	0.75	1.34	0.99	1.55	1.38	1.14
10-15	1.94	1.66	0.74	1.20	2.06	1.00	2.30	2.16	2.35	1.13	1.17	1.67	2.26	1.50	1.43
15-20	1.55	1.83	1.62	1.10	1.71	1.67	2.44	2.28	2.62	4.41	1.43	2.79	2.31	2.78	2.56
20-25	2.23	1.42	2.02	3.23	2.96	0.69	2.69	2.02	3.60	4.65	2.12	3.63	2.36	2.44	1.96
25-30	1.67	0.56	1.69	2.91	3.28	0.73	2.48	1.57	3.68	3.32	1.86	2.28	2.36	2.30	0.42
30-35	0.87	-	-	-	-	-	2.49	2.53	1.43	1.95	1.50	1.25	2.55	2.01	-
	Bug river (point B)														
	B1B	B2B	B3B	B4B	B5B	B6B	B7B	B8B	B9B	B10B					
0-5	1,33	0,56	0,67	0,74	0,36	0,50	0,64	0,63	0,63	0,71					
5-10	1,55	0,95	1,31	0,46	0,97	1,58	1,76	0,96	1,02	0,47					
10-15	1,87	0,96	1,80	0,46	1,37	1,34	1,98	1,06	2,12	3,21					
15-20	1,15	1,49	0,93	0,44	0,69	0,32	0,68	1,39	0,28	1,45					
20-25	0,40	0,74	0,24	0,15	-	1,02	0,50	0,90	-	0,46					
	Bug river (point C)														
	B1C	B2C	B3C	B4C	B5C	B6C	B7C	B8C	B9C	B10C					
0-5	0,50	0,86	0,42	0,16	0,53	0,47	0,37	0,21	1,23	0,39					
5-10	0,47	1,15	1,06	0,50	0,75	0,44	0,56	4,71	2,64	1,39					
10-15	0,68	1,95	1,13	1,45	1,54	0,49	0,96	6,14	1,36	1,25					
15-20	0,96	1,43	1,66	0,80	1,47	0,96	0,53	2,32	0,49	1,15					
20-25	-	0,59	1,33	2,25	-	1,20	1,37	0,55	-	0,73					
	Wieprz-Krzna canal (point B)														
	K1B	K2B	K3B	K4B	K5B	K6B	K7B	K8B	K9B	K10B					
0-5	0,68	0,51	0,70	0,86	0,74	0,60	0,16	0,60	1,21	0,77					
5-10	0,70	1,21	0,79	0,88	1,30	0,76	0,22	0,41	1,16	0,92					
10-15	0,75	1,32	1,11	1,05	1,47	1,20	0,44	0,36	0,77	0,86					
15-20	0,97	1,41	0,87	1,04	1,88	0,34	-	0,76	0,48	1,11					
20-25	1,59	0,49	0,68	0,91	1,54	0,42	-	0,70	1,02	0,90					

The calculation was performed basing on the gamma spectrometric data of the soil profile and assuming that almost all radiocesium originates from Chernobyl (what was proved earlier [11]). Results of migration rate in particular layer of soil profile of "B" and "C" samples (Wieprz and Bug rivers) and "B" samples (Wieprz-Krzna canal) are presented in Table 7.

To abridge the presentation of the results only numerical values (not drawings) of radiocesium migration rate are shown (Table 7). The values of vertical migration velocity of radiocesium in the Wieprz river soil range from 0.99 to 2.11 cm/year (point "B") and from 1.36 to 2.41 cm/year (point "C"). In the case of Bug river these values vary from 0.45 to 1.26 cm/year ("B") and from

0.65 to 2.79 cm/year ("C"). The results of the Wieprz-Krzna canal were calculated only for point "B" and they range from 0.27 to 1.39 cm/year. Above variation of the results describes its change in particular soil profile layer of 5-cm thickness. Observation of this change leads to the conclusion that the smallest migration rate (about 40% of the average migration rate in all profile) is noticed in the first layer (0–5 cm). It means that radiocesium is strongly bound in surface soil. The highest rate is usually observed in the layer of 20–25 cm (Wieprz river) and 15–20 cm (Bug river). This is connected with a presence of the soil leaching horizon at this depth in the soil profile. The results of the Wieprz-Krzna canal are slightly different — the radiocesium velocity in the first layer does not markedly differ with others, deeper layers. This is the additional evidence of different behaviour of radionuclides in soil of natural preglacial valleys and artificial canal built about 40 years ago. Average values of radiocesium migration rate in all analyzed soil profiles are as follows: 1.53 ± 0.42 cm/year (Wieprz river, point "B"), 1.89 ± 0.38 cm/year (Wieprz river, point "C"), 0.98 ± 0.23 cm/year (Bug river, point "B"), 1.17 ± 0.62 cm/year (Bug, point "C") and 0.84 ± 0.30 cm/year (Wieprz-Krzna canal, point "B").

Basing on calculated migration rate of radiocesium an attempt is made to correlate the results with physicochemical parameters of soil (presented in Table 1). It was found that such correlation is rather poor. Therefore the results are not included in this report.

CONCLUSIONS

In the course of our investigations the concentration of natural and artificial radionuclides in soil and sediment samples was determined. The samples were collected in the river valleys of the Wieprz and Bug rivers, and also of an artificial waterway, the Wieprz-Krzna canal. Two lakes of Poleski National Park were studied as well. The results can be recapitulated as follows:

- (i) The granulometric composition of analyzed samples are similar: about 60% of sand fraction and a few percent of silt and clay fractions (only the Wieprz samples reveal about 16% of silt fraction),
- (ii) The exchangeable cation concentration in the samples is also similar in the Bur and Wieprz-Krzna samples, and 10-times lower in the case of the Wieprz samples,
- (iii) The concentration of natural radionuclides changes irregularly down the waterways; a distribution of these radionuclides in soil and sediment is uniform,
- (iv) On the contrary, the artificial radionuclides - radiocesium and plutonium isotopes - in the Bug and Wieprz samples reveal about 4-times lower concentration in sediment than in soil; as concerns the Wieprz-Krzna samples (the artificial waterway) radiocesium concentration in soil and sediment is similar,
- (v) The determination of concentration of radiocesium in samples taken across the lakes shows a cumulation of this nuclide in deep part of the lakes: in the deepest point the activity of ^{137}Cs is several times higher than in soil of the lake bank,
- (vi) The radioactivity of natural nuclides in the soil profile layers, collected down to 40 cm is almost the same; on the contrary, radiocesium concentration decreases very quickly with the depth,
- (vii) The vertical migration rate of radiocesium was calculated applying the compartment model with an assumption that all radiocesium comes from Chernobyl. Obtained migration rate varies from 0.8 to 1.9 cm/year, dependent on the depth.

REFERENCES

- [1] KOMOSA, A., POLISH J. Environm. Studies 8 (1999) 155–160.
- [2] MICHALCZYK, Z., Annales Universitatis Mariae Curie-Skłodowska, Lublin, Sect. B 37 (1982) 151–171.
- [3] CHIBOWSKI, S., J. SOLECKI, J. SZCZYPA, R. SUPRYNOWICZ, Sci. Total Environ. 158 (1994) 71–77.
- [4] Geographical Tables, Adamantan, Warsaw 1998 (in Polish).
- [5] CURRIE, L. A. Anal. Chem. 40 (1968) 586–593.
- [6] BOECKER, B., R. HALL, K. INN, J. LAWRENCE, P. ZIEMER, G. EISELE, B. WACHHOLZ, BURR Jr, W. Health Phys. 60 (1991) 45–100.
- [7] KOMOSA, A. POLISH J. Environm. Studies 7 (1998) 89–93.
- [8] CHIBOWSKI, S. J. SOLECKI, J. SZCZYPA, J. Radioanal. Nuclear Chem. 220 (1997) 183–190.
- [9] KIRCHNER, G. J. Environm. Radioactivity 38 (1998) 339–352.
- [10] BOONE, F.W., M.V. KANTELO, P.G. MAYER, J.M. PALMS, Health Phys. 48 (1985) 401–403.
- [11] CHIBOWSKI, S., J. ZYGMUNT, Z. KLIMOWICZ, J. Radioanal. Nuclear Chem. 242 (1999) 287–295.
- [12] HIROSE, H., S. TAKATANI, M. AOYAMA, J. Radioanal. Nuclear Chem., Articles 182 (1994) 349.

DYNAMICS OF THE CHERNOBYL RADIONUCLIDE MIGRATION IN COVER DEPOSITS OF BELARUS

V. KADATSKY

Institute for Problems of Natural Resources Use and Ecology,
National Academy of Sciences of Belarus,
Minsk, Belarus

Abstract

Transport of the Chernobyl-born radionuclides in cover deposits and different water objects have been studied in the central part of Belarus within the test area, which is drained by the river Isloch (Neman river basin) and its small tributaries. To elucidate the ways of the radioisotope supply into the surface and groundwater the structure of the soil radiocontamination field and the vertical distribution of radionuclides in soils have been carried out. It was found that the structure of the radiocontamination field was regularly changed and local anomalies with a significant increase of the radionuclide inventories ("hot points") formed in some localities. It was revealed that on the average 95% of the radiocesium inventory was spread for a depth of 15–17 cm in automorphic and 9–11 cm in semi-hydromorphic soils. These values for radiostrontium are the 18–20 cm and 14–16 cm., respectively. With this 50 to 80% of the cesium inventory and 35–65% of the strontium inventory are retained in the upper 3–5 cm soil layer. Hence, 14 years after the accident the most portion of ^{137}Cs and ^{90}Sr still occurs much above the groundwater level. As it turned out, radioisotopes are supplied to the surface and ground water both in soluble and in suspension forms. Such a situation being typical of both spring high water and summer low water periods. ^{137}Cs is supplied to rivers mainly with surface and soil-surface water of local discharge in spring. ^{90}Sr migrates to river system with soil-ground and groundwater. The maximum ^{137}Cs and ^{90}Sr concentrations in water of small rivers of the studied territory are much higher than those noted in water of the big rivers of Belarus involved in the radiation monitoring.

INTRODUCTION

Radioisotopes have been studied in the central part of Belarus within the so-called Central radiogeochemical region (Fig. 1). This region was a result of the Chernobyl-born north-western trail superimposed on landscapes of the Belarussian morainic ridge and is described by an averaged ratio of radioisotope inventories in soil $^{90}\text{Sr}/^{137}\text{Cs} = 0.01$ (Kadatsky and Kagan, 1995). The test area "Rodki" is located within this region and shows some special features. Firstly, a territory of the test area is geographically confined to the Main Watershed between the Baltic and Black Seas, so that no other than local radioisotopes are under observation. Secondly, the test area is confined to a catchment of a small river, which favors an assessment of amounts of radioisotopes carried away from landscapes with water. Thirdly, the test area shows a diverse morphology and involves ^{137}Cs and ^{90}Sr territories where different types of economic activities are realized, that permits a correlation of the radioisotope behavior in natural and human changed landscapes, as well as some specific features of their delivery to the surface and ground water.



Fig 1. Scheme of the Chernobyl contamination subdivision within the territory of Belarus. Regions: I - Central, II - Southwestern, III - Eastern, IV - Southeastern. V - "Rodki" test area.

OBJECTS OF INVESTIGATION

Detailed landscape-geochemical studies were carried out within the "Rodki" test area which covers 16 km² (Fig. 2). Its relief is represented by morainic hillocks of the Riss glaciation with isolated kames. More than a third of the territory (37.5 %) is cover by forests, the other part is represented by agricultural (55%) and development (7.5 %) lands. Soddy-podzolic sandy loamy and soddy-boggy soils are widespread. The groundwater is at a depth of 1.0 to 1.8 m.

The test area territory is drained by the river Isloch (Neman river basin) and its small tributaries. According to Horton and Shtraler classification, these are the first-order tributaries (Fig. 1). As known, small water streams of low orders have a direct contact with their elementary catchments and collect the major portion of surface runoff fed by snow melting and precipitation. An interaction between terrestrial ecosystems of elementary catchments and small rivers is realized due to liquid and solid runoff and runoff of water-soluble matter. As a consequence, small streams are the initial components in the course of the chemical material (including radionuclides) transportation by river water. The hydrographic network is partly transformed by the reclamation activities. Its density is 0.41 km/km². The territory occurs in a zone with the total annual precipitation of 550–600 mm. The liquid runoff is at least 216 mm/year.

The natural gamma radiation background was 10–12 µR/h in 1985 before the Chernobyl accident (Chernobyl..., 1996). Chernobyl-born radionuclides were deposited mainly with moisture. The maximum ¹³⁷Cs inventory as of 1989 was as high as 560–570 kBq/m² (Map showing..., 1990). At the same time the spatial distribution of ⁹⁰Sr did not coincide with that of ¹³⁷Cs and its inventory ranged within 1.2 and 5.0 kBq/m² (Lishtvan et al..., 1992).

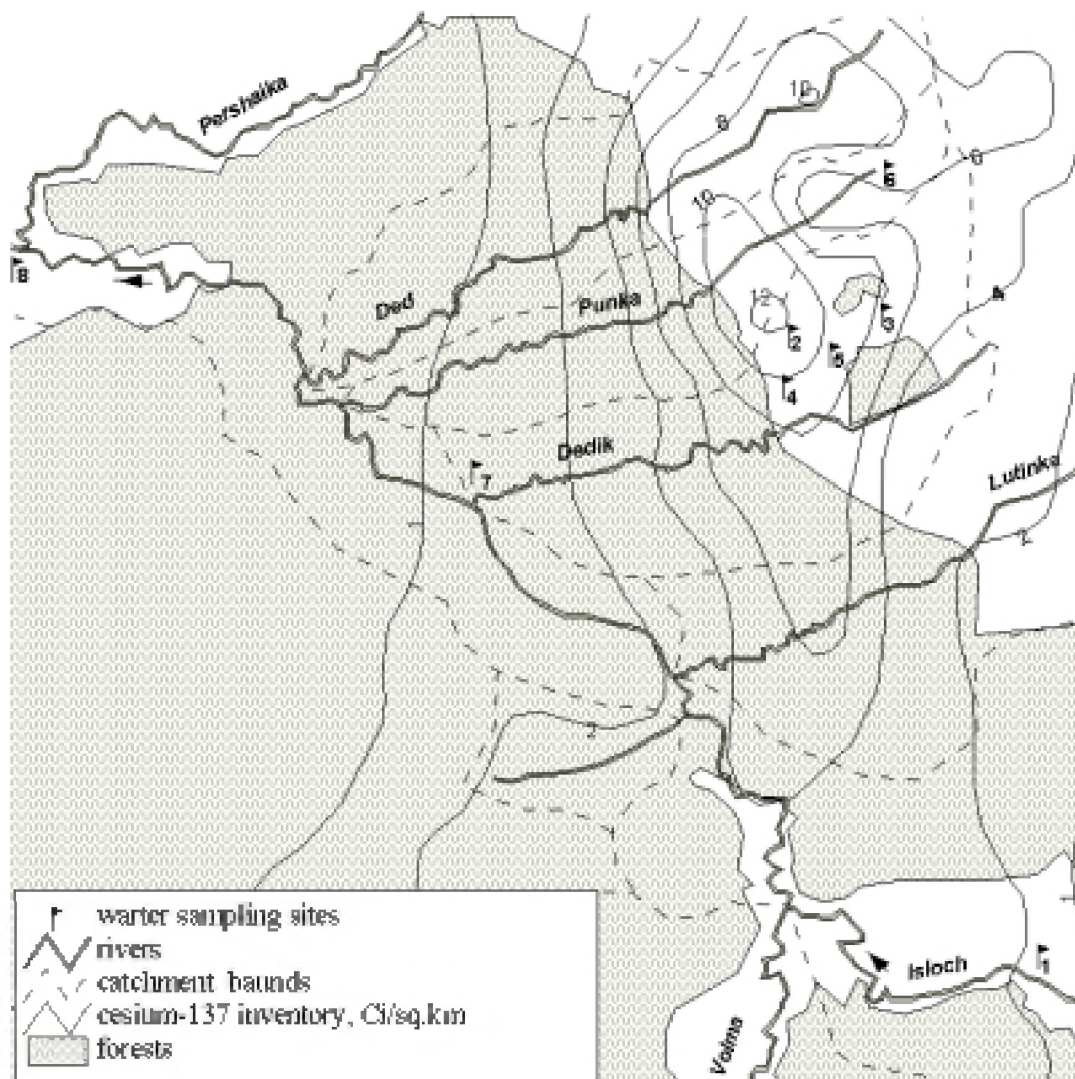

Fig. 2 Test area.

METHODS

A system of landscape-geochemical profiles was used to monitor the gamma radiation dose rate in the studied region. To determine the radioisotope inventories soils were sampled for a depth of 20 cm using a cane-designed sampler. To study the vertical distribution of radionuclides in the soil cover some samples were separated into layers of 0.5 cm.

The surface water specific activity was studied in samples from the following water objects: temporary currents; local runoff accumulations (collapse sink-holes, ponds, abandoned pit); water drains (creeks, small rivers). The river Isloch was sampled at the upper and lower sections, i.e. at the inlet and outlet of the Pershai contamination halo (Fig. 2). Water samples were collected during spring flood (April) to describe the specific activity of the proper surface runoff from the territory of an elementary catchment and during the summer low water to characterize the subsurface runoff into rivers. Ground water was sampled from a spring found on the channel slope 1.2 m above the ground surface.

Radionuclides were extracted from water samples by simultaneous precipitation on standard substrate materials (NaCO_2 , CaCl_2). The activity of soil cover samples, solid residue and

decanted solution was measured with a semiconductor Ge(Li) gamma spectrometer (sensitive area of detector is 200 mm²). The ⁹⁰Sr activity was determined by the radiochemical method based on extraction of the daughter ⁹⁰Y oxalate and subsequent measurement with a beta-spectrometer.

RESULTS AND DISCUSSION

To elucidate the ways of the radioisotope supply into the surface and ground water the study of the structure of the soil cover radiocontamination field was required. Three years' field studies showed that this structure was regularly changed. Local anomalies measuring 0.5 to 25.0 m² with a statistically significant increase of the radionuclide inventories formed in some localities most often confined to critical landscape elements (both natural and technogenic).

Such anomalous formations were named “hot points” in distinction from the known “hot spots” measuring at least 30–50 m² and showing the maximum dose rates three times the local background (IAEA, 1991). Their main difference from “hot spots” is in genesis. The “hot points” are results of nothing but the processes of the secondary redistribution of technogenic fallout in the landscape. Therefore, the morphology and radiation parameters of “hot points” depend on interaction of such factors as microrelief, parcel structure of a biogeocoenosis and technogenic activities (Samsonenko, 2000). Whereas atmospheric turbulence and deposition pattern of radioactive aerosols made certain contribution to the formation of “hot spots”.

It is difficult to identify “hot points” by remote control methods. However, the local mosaic pattern of radiation fields requires special studies for the following reasons. The “hot point” centers are characterized as a rule by rather high radionuclide amounts that are 20 times the background values. Besides, high concentrations of a number of heavy metals - Pb, Cu, Zn, Co, V were noted there. “Hot points” often occur in localities frequently visited by people. Therefore, they may be considered the risk factors.

“Hot points” may be subdivided into major six genetically specific types (Table 1).

Genetic types of “hot points” are confined to specific landscapes (Fig. 3). Parcel-runoff and parcel-hollow “hot points” are peculiar to forest landscapes, the sorption-depression and ecotone ones are mainly found in grassy and agricultural landscapes. “Hot points” of superaqueous type are formed within floodplains. Technogenic-runoff “hot points” form a specific type peculiar to the development and technogenic landscapes. All the types of “hot points” are ecologically dangerous and may become sources of subsequent radioactive contamination of the ecosystem. Besides, some of them are confined to the so-called “hydrological windows” — specific zones, where surface water penetrates into the deeper horizons.

In 2000 on the average 95% of the radiocesium inventory was spread for a depth of 15–17 cm in automorphic and 9–11 cm in semihydromorphic soils. These values for radiostrontium are 18–20 cm and 14–16 cm, respectively. The less intensive vertical migration of radioisotopes in semihydromorphic soils is probably due to the high humus content. With this 50 to 80 % of the cesium inventory and 35–65 % of the strontium inventory are retained in the upper 3–5 cm soil layer. Hence, 14 years after the accident the most portion of ¹³⁷Cs and ⁹⁰Sr still occurs much above the ground water level. Radioisotopes are supplied to the surface and ground water both in soluble form and in suspension. Their supply varies with seasons (Table 2).

TABLE 1. Description of “hot points” within the test area

Hot point type	Genesis	Landscape confinement	DR_{max}/DR_b	A_{max}/A_b
Parcel-runoff	Vertical migration under forest cover	Anisotropic parcel	2 - 5	6 - 16
Parcel-hollow	Vertical migration under forest cover; lateral migration	Microdepression	1,5 - 2	2,5 - 4
Ecotone	Lateral migration	Ecotone	1,3 - 1,5	1,5 - 3
Sorption-depression	Lateral migration	Microdepression	1,2 - 1,5	2 - 4
Superaqueous	Lateral migration	Low floodplain constituents	1,1 - 2	1,5 - 3
Technogenic-runoff	Vertical migration from roofs of buildings	Technosphere element	3-4	6 - 7

Note: 1) DR_{max} – maximum dose rate in “hot point”; DR_b – technogenic background value; 2) A_{max} – maximum ^{137}Cs inventory in "hot point"; A_b - technogenic background value.

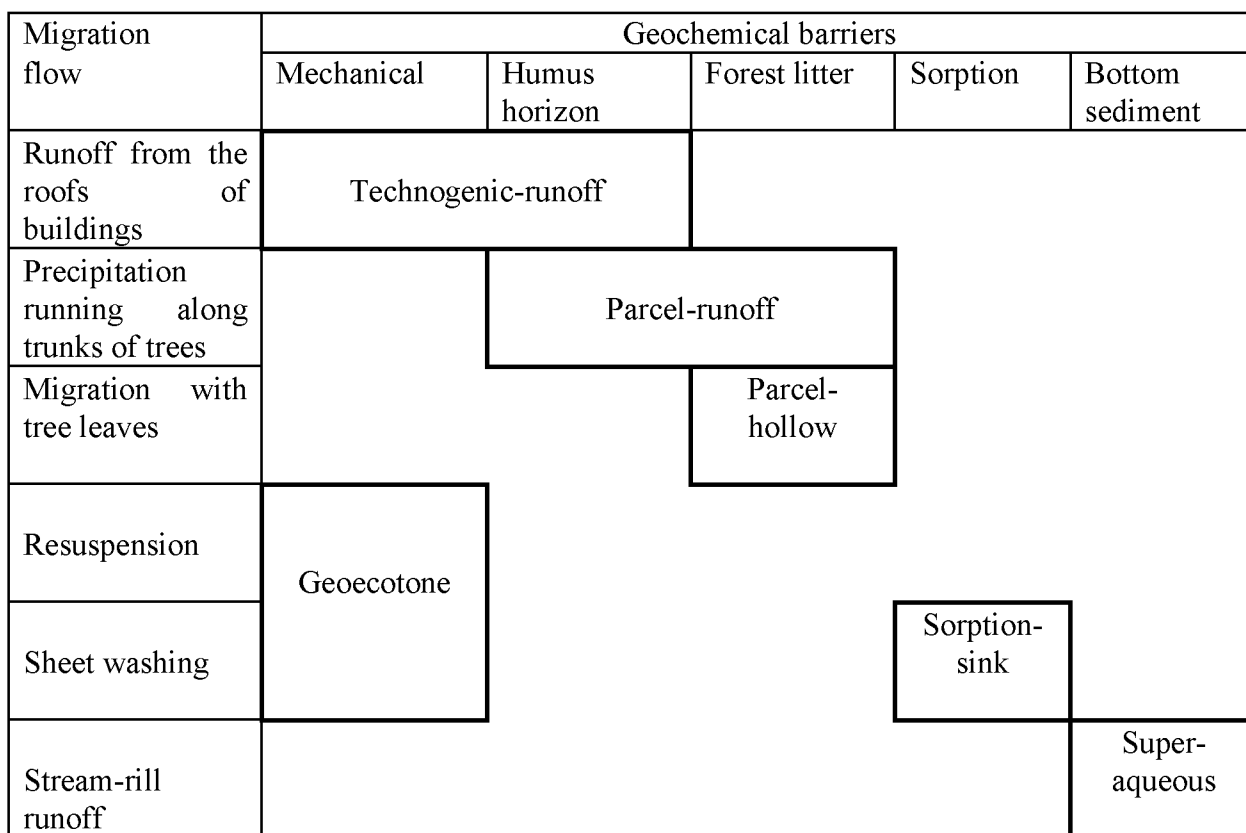

Fig. 3. Scheme of “hot points” genesis.

TABLE 2. Seasonal radioisotope contents of natural water, Bq/l

Water object, Sampling site	Hydrological phase							
	spring high water				summer low water			
	¹³⁷ Cs		⁹⁰ Sr		¹³⁷ Cs		⁹⁰ Sr	
	solu-tion	susp.	solu-tion	susp.	solu-tion	susp.	solu-tion	susp.
Isloch river, upper section	2.36	0.012	5.74	0.011	0.065	0.011	4.16	0,015
Temporary creek	6.58	0.011	3.81	0.021	– *	–	–	–
Sink hole	5.86	0.015	5.14	0.027	0.060	0.010	3.77	1.160
Pond	6.73	0.010	6.02	0.047	0.043	0.010	3.83	0.042
Pit	6.21	0.012	2.46	0.015	–	–	–	–
Dedik river	4.16	0.010	4.35	0.023	0.09	0.016	4.29	0.057
Isloch river, lower section	2.41	0.015	5.68	0.014	0.045	0.010	4.97	0.011
Spring	0.97	0.007	4.59	0.025	0.04	0.012	2.79	0.045

* water is absent

During the spring flood the river water specific activity increased considerably for ¹³⁷Cs (36–53 times as much) and not very significantly for ⁹⁰Sr (1.1–1.4 times as much) as compared to the summer water period. The similar situation is typical of the not running-water objects (sink hole, pond) where the ¹³⁷Cs concentration increased 98–156 times and that of ⁹⁰Sr - 1.4–1.6 times. Radioactivity of spring water also increased: the amounts of ¹³⁷Cs are 24 times and ⁹⁰Sr 1.6 times as much. However the data on the high strontium specific activity have a great interest and require prolongation of research.

The data obtained suggest that the most portion of ¹³⁷Cs and ⁹⁰Sr migrate within the studied test area in solution, such a situation being typical of both spring high water and summer low water periods.

This is in agreement with data on the strontium specific activity of surface water that were obtained as a result of radiation monitoring of rivers draining the Eastern and South-Eastern radiogeochemical regions of Belarus (Fig.1). The behavior of ¹³⁷Cs in surface water is different.

According to the data of radiation monitoring of the natural environment of Belarus (Natural ..., 1997, 1999, 2000) the transportation of ¹³⁷Cs with solid suspensions makes an important contribution to its migration in river water. It is believed that at present this is mainly due to a transition of highly radioactive water sediments into suspension during flood periods, which results in increasing the river water radioactivity in spring. Such a conclusion was made for the case of large and big rivers of Belarus (Dnieper, Sozh, Iput, Besed and Pripyat) showing complicated patterns of their channels.

Our investigations concern with the primary units of the hydrographic network (creeks, small and very small rivers). These are closely connected with their elementary catchments due to runoff of local water (surface-slope, soil-surface, soil-ground and ground) formed in catchments during some specific phases of the hydrological regime. The above may be

confirmed by a specific behavior of a temporary current during spring high water (Table 2) which was formed by proper surface-slope and soil-surface runoff from the territory of the test area. Rather high ^{137}Cs concentration (6.58 Bq/l) in the creek water suggests its considerable inventory within the area drained by the creek, on the one hand, and geochemical conditions favorable for its migration in solution, on the other hand. The situation is similar for the other water objects within the test area (sink-hole, pond, pit, river Dedik). The ^{137}Cs and ^{90}Sr contents of their water are due to the cesium supply with surface-slope and soil-surface runoff and strontium - with soil-surface and soil-ground runoff typical for the spring flood period. It should be also noted that in spring the ^{137}Cs specific activity of water of a number of the studied objects is higher or practically equal to that of ^{90}Sr . An exception is the water of the river Isloch which runs across the studied test area: its strontium specific activity was more than two times the cesium activity.

In summer when rivers and local water bodies are fed by ground water a contribution of ^{90}Sr to the radioactivity of the surface water is increased 48–110 times (Table 2). This suggests the strontium migration with ground water.

Maximum ^{137}Cs (2.36 - 4.16 Bq/l) and ^{90}Sr (4.35 - 5.68 Bq/l) concentrations noted in the water of small rivers during our studies are much higher than those in water of rivers involved in the system of radiation monitoring of Belarus where ^{137}Cs concentration varied from 0.02 to 0.12 Bq/l and ^{90}Sr concentration - from 0.02 to 0.07 Bq/l (Natural... , 1999). At the same time it is necessary to allow, that in spring the radioisotopes removal with water by the studied area is much higher than in summer.

CONCLUSIONS

At present the greater portion of the Chernobyl-born radioisotopes migrate in solution. ^{137}Cs is supplied to rivers mainly with surface and soil-surface water of local discharge. ^{90}Sr migrates to river systems with soil-ground and groundwater.

The radioisotope contamination of river water is higher during the spring flood, as compared to that in summer, this is especially the case of ^{137}Cs contamination. The differences in the ^{137}Cs and ^{90}Sr concentrations are not very important.

The maximum ^{137}Cs and ^{90}Sr concentrations in water of small rivers of the studied territory are much higher than those noted in water of the big rivers of Belarus involved in the radiation monitoring.

14 years after the Chernobyl accident the major portion of radiocesium and radiostrontium is still retained by the upper layers of the soil humus horizon. A decrease of the dose rate of gamma radiation is mainly due to radionuclide decay and suggests that no essential changes are observed in their total supply into the surface and ground water. However, as the pattern of the radiocontamination field is continuously changed and because of economic activities, stagnant water (ponds, pits) may be locally contaminated, that requires the annual monitoring of water in sites where “hot points” occur.

REFERENCES

- [1] Chernobyl. Ten years later. Reference book, 1996. Belarussian Encyclopedia. Minsk, BelEn Publ., 319 p. (in Belarussian).
- [2] IAEA, 1991. The International Chernobyl Project. Assessment of Radiological Consequences and Evaluation of Protective Measures. IAEA. Vienna.
- [3] KADATSKY, V.B. AND KAGAN, L.M. ,1995. Isotopic composition of the Chernobyl fallout in radiogeochemical regions of Belarus. J. Radioanal. Nucl. Chem., Letters, 1999, 325–331.
- [4] LISHTVAN, I.I., LYCH, G.M., KOVALEV, A.A., et al. 1992. Analysis and estimation of losses in economy and natural environment of the Volozhin region due to radioactive contamination. Minsk, Preprint of the Acad. of Sci. , N 5, 119 p. (in Russian).
- [5] Map showing the radiation conditions within the territory of the Byelorussian SSR. The cesium-137 contamination density as of December, 1989. Zapadnoye aerogeodezicheskoye predpriyatiye GUGK SSSR, 1990 (in Russian).
- [6] Methodical instructions for the determination of the strontium-90 and cesium-137 contents of soil and plants, 1985. "Selkhozkhimiya" Publ., Moscow, 21 p. (in Russian).
- [7] Natural environmental conditions of Belarus, 1999. Ecological Bulletin. Minsk, 2000. 192 p. (in Russian).
- [8] Natural environmental conditions of Belarus,1996. Ecological Bulletin. Minsk, 1997. 255 p. (in Russian).
- [9] Natural environmental conditions of Belarus,1998. Ecological Bulletin. Minsk, 1999. 201 p. (in Russian).
- [10] SAMSONENKO, I.P., 2000. Technogenic radionuclides in landscapes of Central Belarus (illustrated with the Volozhin contamination halo). Abstract of the Dissertation Thesis, Minsk, BSU Publ., 20 p. (in Russian).

TRANSPORT OF NATURAL SERIES RADIONUCLIDES AND LIGHT RARE EARTH ELEMENTS IN A COASTAL LAGOON OF A MONAZITE REGION

D. da COSTA LAURIA

Instituto de Radioproteção e Dosimetria (IRD), Rio de Janeiro, Brazil

Abstract

It has been investigated the transport of radionuclides of natural radioactive series and the light rare earth elements in a coastal lagoon system, located in a monazite rich region, in whose water was found abnormal concentrations of radium isotopes and light rare earth elements (LREEs). Four sampling campaigns were carried out: two in rainy and two in dry seasons. Sediment and water samples were collected in seven sampling stations along of the lagoon's 5.4-km. The stations were localized in the map of the lagoon by global positioning system, GPS (figure 1). Still at the field, it was determined the conductivity, alkalinity, Eh and pH in the water and the pH and Eh in the sediment samples. The determination of Ra-226, Ra-228, Pb-210 activity concentrations in the water samples were performed by gross alpha and beta counting (1). The Th, U, light rare earth elements (La-Sm), Ca, Mg, Na, K, Mn, Al and Fe were determined by inductively coupled plasma mass spectrometry (ICP-MS) (Perkin Elmer-Sciex, model Elan 5000 A) by the TotalQuant® method. Argentometric (chloride), turbidimetric (sulfate), cadmium reduction (nitrate), ascorbic acid reduction (phosphate) and selective ion electrode (fluoride) methods determined anions (2). Organic and inorganic dissolved carbons were determined by combustion-infrared method using a carbon analyzer (2). The sediment samples were analyzed by gamma spectrometry, to determine Ra-228 (Ac-228, 911 keV) and Ra-226 (Bi-214, 609 keV) (3), and after sample dissolution by ICP-MS aiming the determination of U, Th and LREE concentrations.

THE ANALYSIS OF WATER

The water analysis showed the decrease of radium (Ra-228 from 1.6 to 0.1 Bq/L; Ra-226 from 0.4 to 0.1 Bq/L) (figure 2) and LREE concentrations (La from 26 to 0.14 µg/L, Ce from 54 to 0.29 µg/L, Pr from 7.18 to 0.08 µg/L, Nd from 29 to 0.15 µg/L and Sm from 4.56 to 0.08 µg/L) in seaward direction. On the other hand, variables as pH (from 4 to 8) and major ion concentrations (salinity from 9‰ to 42 ‰, Cl from 487 to 2300 mg/L, Na from 401 to 1500 mg/L, K from 13 to 67 mg/L, Ca from 7.5 to 112 mg/L, sulfate from 26 to 130 mg/L) increase its concentrations in the same direction. The phosphate concentration was not detected in any sample (the minimum detectable concentration was 0.03 mg/L). The average concentration of dissolved organic carbon was 11 mg/L in all station waters.

By way of the gradient of radium concentration, the source of radium, which was unknown, was found—spring waters at the less brackish zone of the lagoon. The spring waters have circa of 3.5 Bq/L of Ra-228 and 0.7 Bq/L of Ra-226 and pH around 3.7.

Statistical Analysis

Factor extraction from principal component analysis of the variables pointed out three factors as responsible for approximately 82% of the water's data variance: the factor 1 (Ce, La, Nd, Pr and radium isotopes) explained 39%, factor 2 (Na, Cl, K, sulfate, Ca, Mg) 32% and factor 3 (Fe, Mn e U) explained 11%. Thus, the composition of the water of the lagoon can be mainly attributable to Monazite's dissolution (factor 1) and to the seawater (factor 2). The uranium concentration can be attributable to two different sources: seawater and Monazite's dissolution. A discussion in detail will be found in the paper: "Radium origin and fate in a salt coastal lagoon".



Figure 1. Sampling stations on Buena's Lagoon Map.

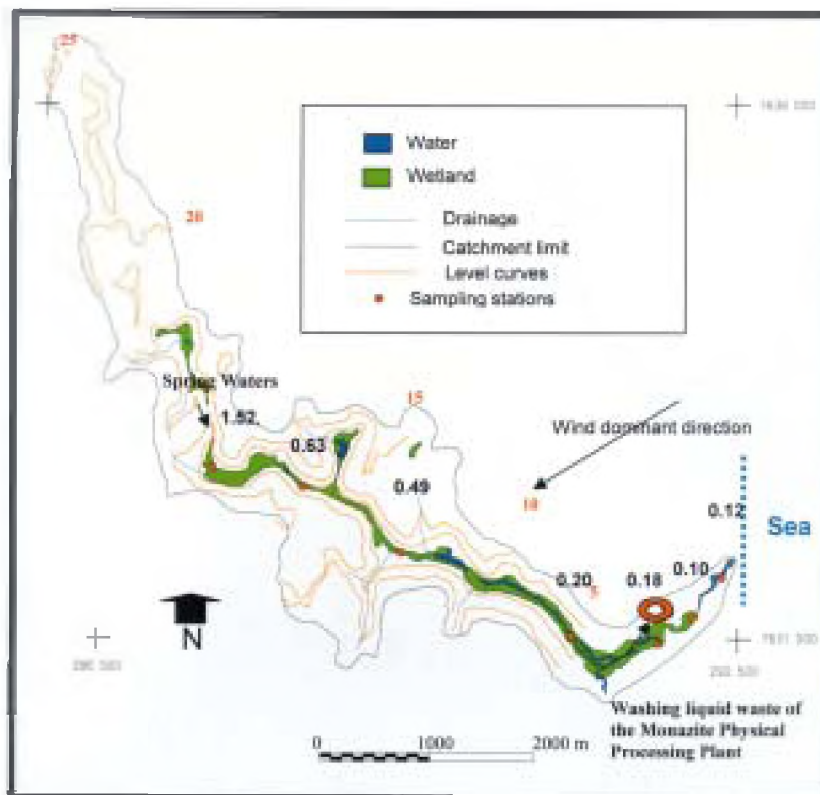

Figure 2. Distribution of the Ra-228 concentration in the water of Buena's Lagoon. Values expressed in Bq/L.

Geochemical Modelling

The speciation of Ra (Ba), U, Th and rare earth elements in the lagoon water was performed using the PHREEQC program, whose databank was complemented by following stability constants: Th: $\text{Th}(\text{OH})^{+3}$ (10,8); $\text{Th}(\text{OH})_4$ (40,1); $\text{Th}(\text{OH})_2^{+2}$ (21,07); $\text{Th}(\text{SO}_4)_3^{-2}$; (10,5); $\text{Th}(\text{NO}_3)^{-1}$ (1,6); $\text{Th}(\text{CO}_3)^{+2}$ (11,0); ThF_4 (23,17) (Lan78); e La: $\text{La}(\text{SO}_4)_2^{-1}$ (5,29); $\text{La}(\text{CO}_3)_2^{-1}$ (12,0); $\text{La}(\text{CO}_3)^{+1}$ (7,4); $\text{La}(\text{Cl})^{+2}$ (0,48); $\text{La}(\text{NO}_3)^{+2}$ (1,13); $\text{La}(\text{F})_2^{+1}$ (6,84) (Woo90). Once as much Th as REEs mobility's are influenced by the organic complex formations and considering the difficulty to set the necessary stability constants for the particular humic and fulvic acid present in the system, with an eye to speciation the dissolved organic carbon (DOC) concentration was assumed as oxalate concentration. Oxalate was chosen as representative bi-dentate carboxylic acid anions (Wood 1993). So, to the PHREEC databank was joined stability constants: $\text{La}(\text{oxalate})^+$ (5,83); $\text{La}(\text{oxalate})_2^-$; (10,41); $\text{Th}(\text{oxalate})_4^{+2}$; (9,30); $\text{Th}(\text{oxalate})_2$ (18,54) and $\text{Th}(\text{oxalate})_3^{-2}$ (Langmuir & Herman).

The speciation calculation was performed for each sampling station using the determined mean value of pH, Eh, major ions, Th, U, La (representing the LREEs) Fe, Al, Si, Mn, F⁻, carbonate, nitrate, and DOC (as oxalate) concentrations. The results of speciation calculations are showed in figure 3, 4 & 5.

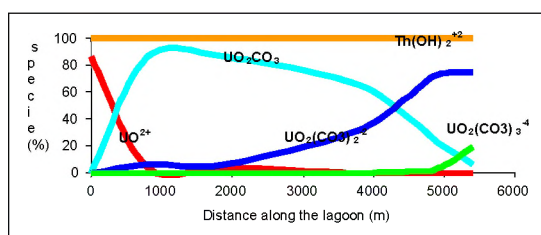

Figure 3. Uranium and thorium predominant species along the lagoon.

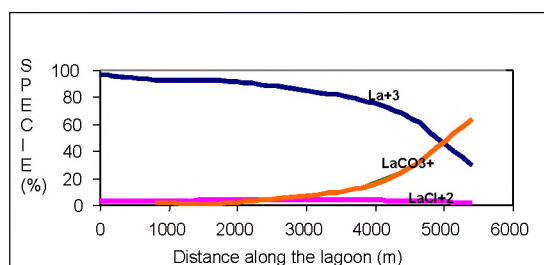

Figure 4. Inorganic speciation of lanthanum (LREEs) along the lagoon.

As a result of the calculation some conclusions may be drawn from fig.3, fig. 4 and fig.5. In all stations Ba (Ra) is as free ion and Th is as hydrolyzed form. The uranium- carbonate complexes can be formed from station 2. For the light REE, La, the simple ion (La^{+3}) predominates at station 1, pH 4, the first oxalate complex (LaOx^+) could be formed from station 2. La could form inorganic complexes (LaCO_3^+) only at station 7. This result pointed out to the possibility for REE free ions being adsorbed on the sediment at station 1, explaining the sudden decrease of REE concentrations observed in the lagoon water column, figure 6.

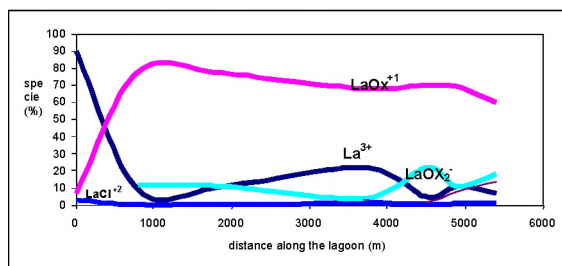

Figure 5. Organic speciation of lanthanum (LREEs) along the lagoon.

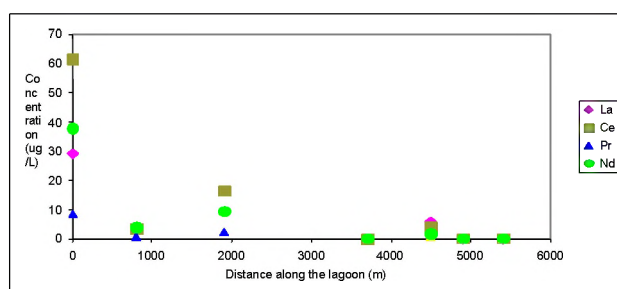

Figure 6. Distribution of light rare earth element concentrations along the lagoon.

THE ANALYSIS OF SEDIMENT

Predominantly the clay of the sediments is kaolinite, typical clay of very weathering environment as tropical one. Sediments of the lagoon have different characteristics: The pH ranged from 3.8 to 8.2, the content of organic carbon from 0.42 to 5.49% and cation exchange capacity from 3.5 to 15.0 cmol/kg. The ranging of nuclide concentrations was: Th from 7 to 1310 mg/kg; U from 17 to 1380 mg/kg; Ra-226 from 5 to 861 Bq/kg; Ra-228 from 19 to 5762 Bq/kg; La from 12 to 2085 mg/kg; Ce from 26 to 3159 mg/kg; Pr 7 to 609 mg/kg; Nd from 23 to 2330 mg/kg and Sm from 3 to 360 mg/kg. Table 1 provides a summary of radionuclide levels observed during the survey of sediment from different sampling sites.

The highest nuclide concentration was found at station 5, where the washing water from the physical processing of Monazite is released. Thus, the sedimentation of the solid particles, which go along with the processing washing waters, is responsible for the highest observed concentrations.

TABLE1. Values of geometric mean and geometric standard deviation of nuclide concentrations in sediment from sampling stations

Station	1=2=3=6 Mean (deviation)		4 Mean (deviation)	5 Mean (deviation)	
La (mg/kg)	41 (1,8)		235 (1,3)	1088 (2,7)	
Ce (mg/kg)	81 (1,7)		453 (1,2)	1626 (2,8)	
Pr (mg/kg)	13 (2,0)		54 (1,3)	351 (2,3)	
Nd (mg/kg)	39 (1,6)		193 (1,2)	1132 (3,1)	
Sm (mg/kg)	7,9 (2,3)		29 (1,3)	200 (2,6)	
Station	1	2=3=6 Mean (deviation)	4 Mean (deviation)	5 Mean (deviation)	
U (mg/kg)	6,9	3,0 (1,6)	9,9 (1,6)	93 (1,2)	
Station	1=2 Mean (deviation)	3=6 Mean (deviation)	4 Mean (deviation)	5 Mean (deviation)	
Th (mg/kg)	29 (1,2)	11 (1,3)	111 (1,3)	1143 (1,1)	
Station	1=2=3 Mean (deviation)		4 Mean (deviation)	5 Mean (deviation)	6=7 Mean (deviation)
Ra-226 (Bq/kg)	32 (1,4)		96 (1,5)	366 (3,8)	14 (2,2)
Ra-228 (Bq/kg)	81 (1,3)		314 (1,4)	3687 (1,6)	46 (2,0)

After the sediment from station 5 (4500 m), for all nuclides the higher concentrations were found in sediment from station 4 (3700 m), which suggested possible monazite occurrence at the local. Even though the concentrations in sediments from station 5 and 4 are not considered, the nuclide concentration distributions along the lagoon are quite different: LREE concentrations were similar in sediments from the stations 1 (0 m), 2 (800m), 3 (1900 m) and 6 (4900 m), showing a similar distribution along the lagoon. For radium isotopes the concentrations value are similar in stations 1, 2 and 3 and lower at station 6. Thorium is more concentrated in sediments from station 1 and 2 than in sediments from station 3 and 6, while uranium is more enhanced in sediment from station 1 than in sediments from station 2,3 and 6, which have similar concentrations (table 1).

The Pearson correlation analysis showed a very good correlation among radionuclides, lanthanum and cerium in sediments, alluding to their monazite origin. Otherwise correlation among Fe, pH and organic matter in sediments and monazite nuclide concentrations were not found.

In order to validate the methodology used to determine the nuclides by ICP-MS, the analysis of the lake sediment IAEA reference material (IAEA-SL-3) was carried out using the same proceeding of the sediment samples. The obtained results showed that the applied methodology has enough accuracy and repeatability for this study objective.

Sediment Speciation

There have been numerous studies for elucidating of radionuclides partitioning between the residual and non-residual phases and between different grain size fractions of sediment. This kind of study aims to elucidate possible factors, which influence the natural enhancement of radionuclides

concentrations in sediment. Two experiments were performed to investigate the distribution of adsorbed radionuclides in the different fractions of the lagoon sediments. As the sediment from station 5 has been impacted directly by the processing plant, for comparison effects the results of its sediments will be not considered.

- 1) Physical separation: This experiment was performed in order to examine the importance of the grain size in influencing the radionuclide adsorption along the lagoon. The sediments from the different sampling stations were separated in $< 63 \mu\text{m}$ (predominately silt+clay) and 63–2000 μm (sand) fractions by wet sieving and so these fractions were analyzed for naturally radionuclides and REEs.

Figures 7, 8 and 9 show the nuclide concentrations in the finer fraction of the sediments along the lagoon. The highest nuclide concentrations in the fraction $< 63 \mu\text{m}$ was found in the sediment from station 4.

Radium isotopes are much more enhanced in the finer fractions than the other nuclides, their concentration ratios $Ra_{\text{finer}}/Ra_{\text{sand}}$ ranged from 3 to thousands. This outcome points out the preference of radium for finest particles, which could be attributed to importance of surface adsorption phenomenon in its uptake. LREEs and Th preferences for linking in finer fractions is great but not so clear, for LREEs the concentration ratios finer to sand ranged from 0.9 to 5, being at station 1 the only found value less the 1, while Th's ratios ranged from 0.3 to 4, being the value less than 1 found in sediment from stations 1 and 6. Otherwise the uranium is mainly associated on sand fraction (stations 2,3 and 6), only at station 1 its concentration in finer fraction was higher than in sand fraction. The enhancement of Ra over U on finer particles can be observed comparing their concentrations in the two fractions. The ratio Ra-226/U-238 concentrations in finer fraction ranged from 1 to 17, while in sand fraction ranged from 0.0005 to 0.8. This results point out to Ra-226 enrichment in the finer particles and a impoverishment in sand fraction. However for Th's serie the behavior is a little different: Ra-228 enrichment in the finer fraction is similar to Ra-226, the ratio Ra-228/Th-232 ranged from 4 to 15, but in sand fraction the ratio ranged from 0.1 to 6, being in three stations the value higher than 1 (stations 2, 4 and 6). This contradictory behavior in the sand fraction could be explained by the structure of the mineral component of the sediment. A nuclide will be more or less available to be leach depend on it links on the mineral. The Ra-228 has shorter half-life than Ra-226 and is almost directly produced by the Th-232 decay, while Ra-226 ingrown depends on the decay of three radionuclides of long half-life: U-238, U-234 and Th-230. Because of that, the production rate of Ra-228 in the sediment is more elevated than the Ra-226 one. Product of three sequential alpha-decay, it is possible that due to more elevated number of crystalline breaking, Ra-226 be more easily leached than Ra-228. However, a more detailed study of the radionuclides balances in the sediment will be helpful to explain the found results.

TABLE 2. Distribution of nuclides between $< 63 \mu\text{m}$ and 63-2000 μm fractions of sediments, concentrations of Ra (Bq/kg) and others (mg/kg)

Station	Ra228	Ra226	Th232	U238S	La	Ce	Ra228	Ra226	Th232	U238	La	Ce
	Sand	Sand	Sand	and	Sand	Sand	$< 63 \mu\text{m}$	$< 63 \mu\text{m}$	$< 63 \mu\text{m}$	$< 63 \mu\text{m}$	$< 63 \mu\text{m}$	$< 63 \mu\text{m}$
0	14	0.004	36	6.7	68	149	290	127	11	8.3	58	129
800	47	22	4.1	2.2	12	16	260	65	8.7	0.32	17	31
1900	4.3	1	7.3	4.3	12	6	155	60	10	2.6	57	117
3700	392	89	15	16	40	60	1240	305	55	2.3	109	189
4900	41	17	6.8	2.7	11	24	196	70	3.2	0.55	17	33

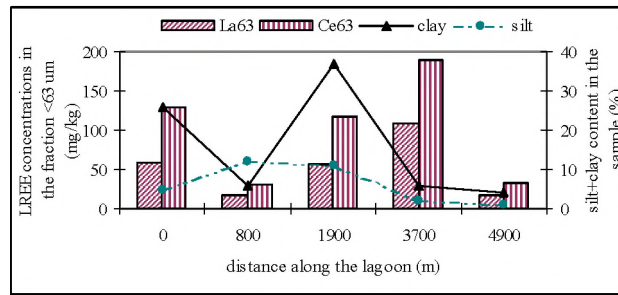

Figure 7. Distribution of LREEs in the fraction < 63 μm of the sediment.

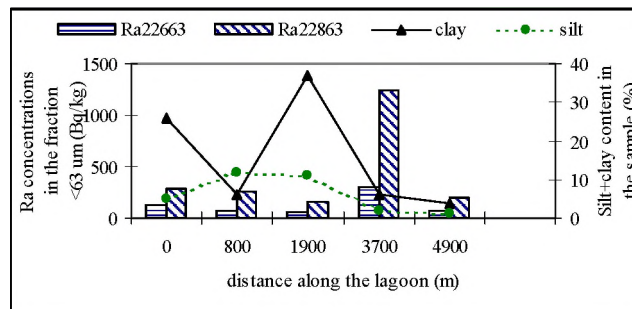

Figure 8. Distribution of radium isotopes in the fraction < 63 μm of the sediment.

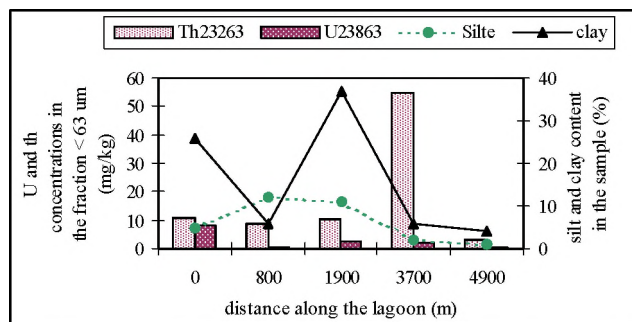

Figure 9. Distribution of U and Th in the fraction < 63 μm of the sediment.

No direct correlation was found among silt and clay contents and nuclide concentrations in finer fraction. Although the sediment from station 3 is the only containing some ermechite, a clay of more elevated change capacity than kaolinite, its sediment not reflects the enhancement of change capacity over the others. In fact as the kind of clay as the quantity of silt and clay seems not influence straightly a rise of nuclides in the sediment fraction.

- 2) The second experiment was performed aiming to investigate the distribution of the nuclides between the residual (those nuclides associated with sediment matrix) and non-residual fraction (those which have been incorporated in the sediment from aqueous solution) of the

sediment. The sediment from the sampling stations were leached with cold HCl 0,5 M, during 16 hours, the ratio between the aquo/solid phase was 20. After the phase separation nuclide concentrations were determined in the leaching solutions. The technique is suitable to isolate elemental association and it is recommended for estimation of adsorbed, organic and precipitated phase of trace metals.

TABLE 3. Nuclide concentrations in residual and non-residual fractions of the sediment. Ra isotopes (Bq/kg); others (mg/kg).

Distance (m)	Ra226 R	Ra288 R	Th232 R	U238 R	La R	Ce R	Ra226 nR	Ra228 nR	Th nR	U nR	La nR	Ce nR
0	26	82	36	2.2	77	135	13	22	1.41	4.7	9.8	37
800	16	56	5.2	2.1	13	17	17	38	0.45	0.16	1.7	4.4
1900	17	49	12	3.6	20	9	12	29	0.35	1.9	20	53
3700	108	465	19	16	46	68	5.4	26	0.15	0.19	2.8	6.9
4900	15	36	7	2.5	9	19	4.9	15	0.04	0.29	2.6	7.0

For all nuclides the smaller concentrations in the non-residual phase were found in the sediment from station 4 (3700 m). Comparing this finding with the high concentrations observed in the finer sediment fraction from this station, one can conclude that the high concentrations owing to non reactive fine mineral particle in the sediment (monazite sand fine particles?). The concentrations of Th in the non-residual phase (figure 6) were the lowest among the other nuclides, which is consistent with the Th tendency to hydrolyze easily and to be highly particle reactive in aquatic system. The Pearson correlation indicated a good correlation ($r=0,87$) between the radium concentrations in the non-residual phase and the silt content in the sediment (figure 4), showing the importance of finer particle to radium adsorption. For LREEs but a good correlation was found with the changeable fraction in the sediment ($r=0,95$) (figure 5), being an indicative of the mechanisms of adsorption of these nuclides on the sediments.

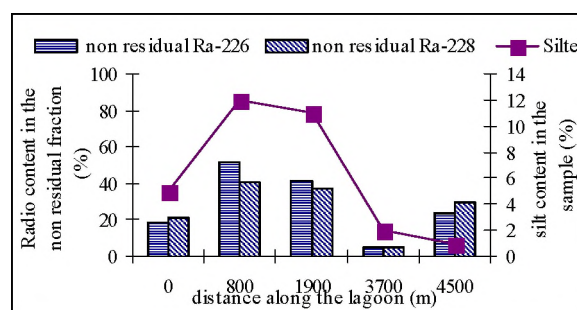

Figure 10. Radium isotopes in the non-residual fraction related to silt content in sediment.

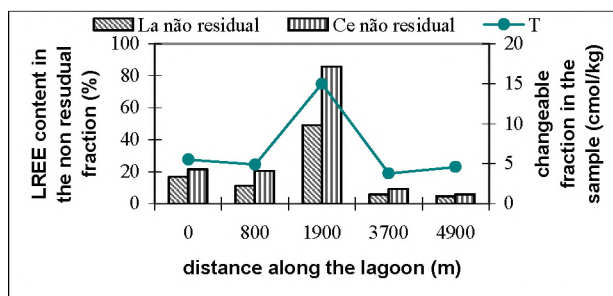

Figure 11. LREE concentration in the non-residual fraction and the changeable fraction of the sediment.

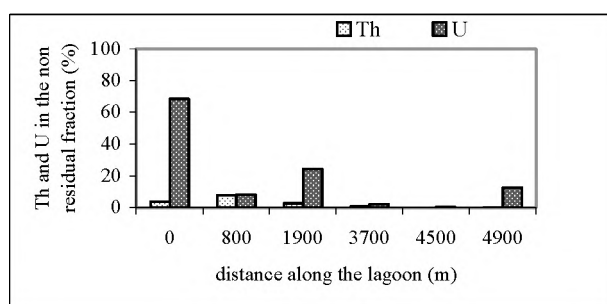

Figure 12. Distribution of thorium and uranium in the non residual fraction along the lagoon.

CONCLUSIONS

The source of radionuclides and LREEs to the lagoon water is groundwater, whose pH is low, being the springs located 5.4 km far from the sea and 0.1 km far from the lagoon head. The leaching of monazite is responsible for the nuclide concentrations in the groundwater, which is incited by the low pH value of the water. The source of radium isotopes and LREEs (groundwater) and the source of major ion concentrations (seawater) are localized in opposite sites of the lagoon. The radium isotopes and LREEs concentrations decrease in the seaward direction, while the pH and the major ions concentrations increase. Both distributions could be fitted by exponential functions of the distance from the spring waters. Ra is as free ion and Th is as hydrolyze form in all extension of the lagoon, while uranium-carbonate complexes and light rare earth elements-organic complexes could be formed along the lagoon. The lagoon sediments have different chemical characteristics and nuclide concentrations. Monazite sand occurrence was identified at a local in the lagoon. The sediment speciation pointed out the great importance of finest particle on absorption of Ra, especially the silt fraction, showing that surface adsorption phenomenon plays a great role in its uptake. The light rare earth elements are mainly associated to the finest particle of the sediment and the ionic change seems to be an important process for their incorporation on the sediment.

REFERENCES

- [1] GODOY J.M. “Methods for Measuring radium isotopes: Gross alpha and beta counting”, The Environmental Behaviour of Radium, Technical Reports Series No.310, International Atomic Energy Agency, 205–212, 1990.
- [2] Standard Methods for Examination of Water and Wastewater, 14th edition, American Public health Association, Washington, 1975.
- [3] CARNET A. AND JACQUEMIN R. “Methods for Measuring radium isotopes: Gamma spectrometry”, The Environmental Behaviour of Radium, Technical Reports Series No.310, International Atomic Energy Agency, 189–204, 1990.

RESEARCH INTO SPECIFIC NATURE OF POLLUTANTS MIGRATION WITHIN SUBSURFACE SPACE OF LARGE SCALE INDUSTRIAL AND URBAN AGGLOMERATIONS BY ISOTOPE TECHNIQUES

V. GUDZENKO

Research & Development Centre of Radiohydroecological Investigations,
Academy of Sciences of the Ukraine, Kiev, Ukraine

Abstract

During the study of the past accident groundwater radionuclide contamination of main aquifers at the area of Kiev Industrial and Urban Agglomeration (KIUA), measurable amounts of ^{137}Cs and ^{90}Sr had been determined on the relatively high depth. In the first stage of sampling more than 20 wells had been observed contained the trace amounts of short living ^{134}Cs (Goudzenko, 1993). Further observations support the previous results for the ^{137}Cs and ^{90}Sr in the wells of municipal water supply system in the city of Kiev and suburbs. Maximal concentrations of ^{137}Cs for the upper aquifer, located in the Quaternary deposits, reach up 50 odd mBq/l in 1992. The same figure for ^{90}Sr was about 20 mBq/l. For deeper aquifers such as Neogene, Palaeogene, Cretaceous and Jurassic maximal concentration in the groundwater were some less, but in the same time, over 20 and 10 mBq/l respectively. Concentration of ^3H in these water bearing sets reach up several Bq/l. So deep and quick penetration of radionuclides from the daylight surface to the groundwater compels to search for suitable pathways and mechanisms of their movement. Despite of concentrations of decay products in the groundwater of KIUA today are far from the permissible levels, the investigation of this phenomenon seems to be very important. A lot of possible contaminants, generating in IUAs, may move through the unsaturated zone by the same mechanisms as radionuclides. Measurable amounts of ^{137}Cs and ^{90}Sr had been determined too sometimes in the soils and rocks of Kiev on the depth up to 300 m. The Chernobyl origin of these nuclides, as mentioned above, had been confirmed during the first stage of investigation. Simultaneously with going on monitoring of ^{137}Cs and ^{90}Sr in the water intake wells of municipal water supply system, the range of marl samples had been collected from the constructing metro tunnels, water, sediments and sinters from drainage adits, built on the slopes of Dnieper valley and its little tributaries to protect slides. Main goal of these sampling was to obtain the most correct data, supporting the idea of quick radionuclides' migration in the undisturbed (or slow disturbed) conditions. The next branch of efforts was the study of ^{137}Cs redistribution in the soil profiles near the operating wells of municipal water supply system. Some results obtained had been used for modelling of contaminants migration from the daylight surface to the groundwater.

SCIENTIFIC BACKGROUND AND SCOPE OF PROJECT

Powerful contamination of daylight surface in the areas, influenced by radioactive fallout after the Chernobyl disaster, allowed to use some of decay products as tracers for the study of water bodies pollution specifics. Located on the distance about 100 km from the Chernobyl Nuclear Power Plant (CNPP) Ukrainian capital — city of Kiev — had been contaminated during the spring 1986 by ^{137}Cs with an average density of 30 kBq/m². In the separate points this parameter reached up 185 kBq/m² odd. Sampling session on 1990–1991, when upper parts of soil profiles had been collected near the mouthes of the operating wells, had shown some distinctions between different parts of the city. Results of measurements represented in the Table 1. So geological medium inside the Kiev Industrial and Urban Agglomeration (KIUA) was labelled with active tracer, which permitted to search some processes of water and mass transfer under the specific conditions of urbanised territory.

The range of subjects of the environment had been selected for the monitoring and separate measurements of ^{137}Cs concentration to support or reject idea about the existence of abnormal quick pathways for Chernobyl origin radionuclides penetration in the geologic medium.

TABLE 1. Daylight surface contamination density for ^{137}Cs in the different parts of Kiev city, kBq/m², 1990–9191

Parameters	Part of the city			Total means
	Right bank, low sites of territory, including Dnieper's floodplain	Left bank, Dnieper's floodplain	Comparatively elevated parts of right bank territories	
Number of observation	10	8	5	23
Average means	33.99	37.44	20.74	32.31
Standard deviation	28.18	36.81	12.09	28.70
Min	7.15	9.35	7.63	7.15
Max	91.70	123.68	39.61	123.68

EXPERIMENTAL METHOD

Main method used was a careful sampling and measurements of ^3H , ^{137}Cs and ^{90}Sr from the selected objects to avoid artificial contamination of patterns during operation.

Concentration of Tritium (^3H) had been measured in the Ukrainian National Centre of the Radiation Medicine (UNCRM) by liquid scintillation technique on the “Quantulus” 1220TM Wallac spectrometer. Water samples prepared by distillation and measured with Optiphase High Safe Scintillator without previous enrichment. Every sample had been measured 7 times with exposition of one hour. Minimal detectable activity varied from 0.7 to 1.0 Bq/l. Statistical uncertainties varied from 7 to 100 odd percent.

Concentration of γ -emitting radionuclides had been measured by semiconductor Ge(Li) spectrometer SBS-55 with a resolution about 2.4 keV at the energy of 661 keV in the standardised geometry. Exposition time about a day allow to reach sensitivity less than 0.5 Bq per sample for ^{137}Cs . Soils and rock samples were drying and crashing according to standard procedure. Water samples has been preparing by three different techniques:

- evaporation of acidified samples:
- sorption of ^{137}Cs by artificial selective sorbent so called “Mtilon-T”, impregnated with ferrocyanides, or by the mixture of ionite exchange resins (KU-2 and AV-17);
- classical radiochemical preparation.

Concentration of ^{90}Sr had been determined by two techniques:

- classical radiochemical preparation or
- measurements by hard β -emitters (^{90}Y) on the selective β -spectrometer RUB-91 (produced by “Advanced Analytical Instruments (AdAnI), town of Minsk, Belarus).

The first version had been used for the most water samples from KIUA with the levels of ^{90}Sr concentrations dozens-hundred mBq/l. The second one- for the soils, rocks and water from the

alienated zone around the CNPP. Sensitivity of RUB-91 for thin samples allow to measure about 0.2 Bq/sample for 10000 second exposition. Evaporation of the acidified samples seems to be very useful for the β -spectrometerical measurements due to practically 100% yield of nuclide.

During the interpretation of results obtained additional hydrogeological and meteorological parameters had been used, as like as data of geological specifics of the objects under study.

RESULTS OBTAINED

Groundwater was the first object, which begun to be studied after the disaster. In the network of CRP we gone on to measure radionuclides' concentration from the different sources of the groundwater inside the KIUA. Results obtained for ^3H , ^{137}Cs and ^{90}Sr distributions are represented in the tables 2–4.

TABLE 2. Tritium distribution in the groundwater of Kiev-city and suburbs. Bq/l, 1997–1999

Parameters	Sources of groundwater						
	City-of-Kiev			Suburbs			
	Springs	Wells (K ₂ &J ₂)	Adits	Wells, Q	Wells, P ₂	Springs	Lizimeters
Number of observation	8	13	5	10	10	6	9
Average means	5.27	3.22	4.522	2.744	1.654	4.965	4.609
Standard deviation	2.079	1.37	2.124	1.056	1.295	2.617	0.932
Min	2.56	1.36	2.20	1.44	0.1	2.94	3.40
Max	9.35	5.56	7.53	4.17	4.39	9.87	6.60

As they can see from the table 2, average concentration of tritium in the groundwater in the city of Kiev are significantly higher than that in the suburbs, especially for wells and springs, despite of bigger depth of main aquifers in the city. Taking into account existence of a deep depression cone, formed as a result of long term water intake, distribution of ^3H distinctly reflects differences in the velocity of water exchange between the central part of city and the rest area of KIUA.

TABLE 3. Distribution of ^{137}Cs in the groundwater of Kiev-city and suburbs. mBq/l, 1997–1999

Parameters	Sources of groundwater					
	City-of-Kyiv			Suburbs		
	Springs	Wells (K ₂ &J ₂)	Adits	Wells, Q	Wells, P ₂	Springs
Number of observation	4	52	8	10	10	6
Average means	286	6.6	5.72	10.13	3.04	4.965
Standard deviation	155	4.15	3.24	4.09	1.791	2.617
Min	13	2.20	0.5	5.44	0.1	2.94
Max	688	21.1	8.90	16.54	4.88	9.87

TABLE 4. Distribution of ^{90}Sr in the groundwater of Kiev-city and suburbs. mBq/l, 1997–1999

Parameters	Sources of groundwater			
	City - of - Kiev		Suburbs	
	Wells, K ₂	Wells, J ₂	Wells, Q	Wells, P ₂
Number of observation	28	24	10	10
Average means	1.78	3.22	9.77	0.604
Standard deviation	1.24	2.04	11.09	0.473
Min	0.40	0.40	1.11	0.39
Max	4.70	6.90	32.38	1.94

A glimpse on the tables 3 and 4 right away shows a differences between retardation characteristics of ^{137}Cs and ^{90}Sr . Whereas area contamination of KIUA for ^{137}Cs at least order higher than for ^{90}Sr , their concentrations in the groundwater of municipal water supply system are comparable. Average concentration of ^{90}Sr in the Jurassic aquifer was even higher than that in the Cretaceous one, as like as in the Palaeocene aquifer in the suburbs.

So groundwater of KIUA is more or less contaminated with decay products, of Chernobyl origin, as mentioned above.

To intercept downward water flow, carrying ^{137}Cs and ^{90}Sr , a range of samples had been collected in the drainage adits of landslide slopes.

Ground, soil, sinters and water of the drainage adits were the next subject of our attention. Drainage adits systems in the city-of-Kiev are stripping Quaternary, Neogene and Palaeogene sediments, containing groundwater.

The first from the daylight surface water bearing horizon locates in the Quaternary deposits. As usual it feed by direct infiltration of precipitation. Groundwater in so-called “poltava sands” of Neogene are observed as separate lenses on the elevated parts of Kiev plateau. Water bearing horizons wide spread in the Palaeogene sediments.

Ninety seven landslides are known in the Kiev area. Underground drainage for landslide slopes stabilization had been used from the end of XVIII century. As usual recent drainage systems are constructed in Kiev marls, Neogene or Quaternary clays and drains overlying Palaeocene or Quaternary sands and sandy loams. Some adits equipped with ascending wells and filters, which allow to collect groundwater directly from the horizon.

Some data concerned nuclide’s distribution in the soils over the drainage systems (possible sources of contamination), rocks inside the adits and calc (ferriferous) sinters represent in the table 5.

As they can see from the table 5, filtration ways vary from 4 to 28 meters. Water samples had been taken mainly from the mouths of the descending drainage wells, drilled from the adits. Rocks and sinters had been collected near at hand. Soil from the daylight surface had been collected at the area, influenced by adjacent system and had a thickness of 20 cm. We have to mark the significant variability of soil’s contamination. Presence of the measurable amounts of ^{137}Cs in the rocks from adits we cannot consider as a result of contamination by a polluted infiltration flow, because we cannot exclude the possibility of airborne transfer, as described in (Klimchouk & Gudzenko 1996).

TABLE 5. Radioactive contamination of drainage systems in the city-of-Kiev

Number or name of the system	Draining horizon	Depth of filter, m	Concentration of ¹³⁷ Cs, Bq/l (kg)			
			Water	Soil from surface	Rocks from adits	Sinters
27	Q	28	0.006	1739	12.2	bdl
41	Q	7.5	0.002	37	48.1	17
43	P ₃ hr	8	0.009	85	4.8	22
46	Q	10	0.007	592	8.9	bdl
47	P ₃ hr	13	0.009	144	63	7
59	P ₃ hr	8.5	bdl	592	bdl	bdl
60	Q	4	bdl	79	bdl	bdl
60	P ₃ hr	13.5	bdl	The same	bdl	bdl
61	Q	4	0.005	444	9.2	bdl
62	Q	13.5	0.006	144	19.6	1.85
64	Q	9	bdl	92	133	bdl
66	Q	8-11	0.006	52	8	bdl
Riviera	P ₃ hr	15	bdl	111	4.1	bdl

bdl - below detection limit

Much more weighty evidence of infiltration flow's pollution are a measurable concentration of ¹³⁷Cs in some sinters. Velocity of the so called "cave pearls" and another carbonates formation is very high, so during 10 years odd after the disaster they had time to accumulate radioactivity from the dissolved components, transferred by an infiltration flow.

During downward migration inside the large depression cone of KIUA polluted water interacts with rocks on the pathway, so results of this interaction may be reflected in the geologic matrix. For check of this assumption cores of some new built wells had been sampled and carefully measured by γ -spectrometer.

Contamination of cores had been studied on the several patterns in the KIUA and alienated zone around the Chernobyl Nuclear Power Plant (CNPP).

One of the wells locates about 25 km West from the centre of Kiev-city in the valley of Dnieper's right tributary - river of Irpin'. Areal contamination of this territory for ¹³⁷Cs is about 40–50 kBq/m². Depth of the well - 92 m. Under the soil-plant layer the bore-hole cuts loams and sands of Quaternary deposits, green clays and marls of upper Palaeogen, water bearing sands of so called "buchak" and "kanev" deposits, underlying by the sandstone. 18 samples had been collected during the drilling - 6 from the upper 10 m zone, 9 from the clay-marl strata, located on the depth 32–54 m, and 3 samples - from the saturated sands on the depth 72–82 m. Beside of ¹³⁷Cs content, concentrations of naturally occurring ⁴⁰K, ²¹⁴Bi (progeny of ²²⁶Ra), ²²⁸Ac (progeny of ²³²Th) and ²³⁵U concentrations in the rocks had been determined. Results obtained represented in the Fig. 1. Despite of the different radionuclides' origin their visible correlation may reflect sorption ability of rocks on the filtration pathways. Summarized data of this well study is presented in the Table 6.

Concentration of ¹³⁷Cs in the Kiev marl about 3 Bq/kg may be the result of interaction between matrix and contaminated infiltration flow.

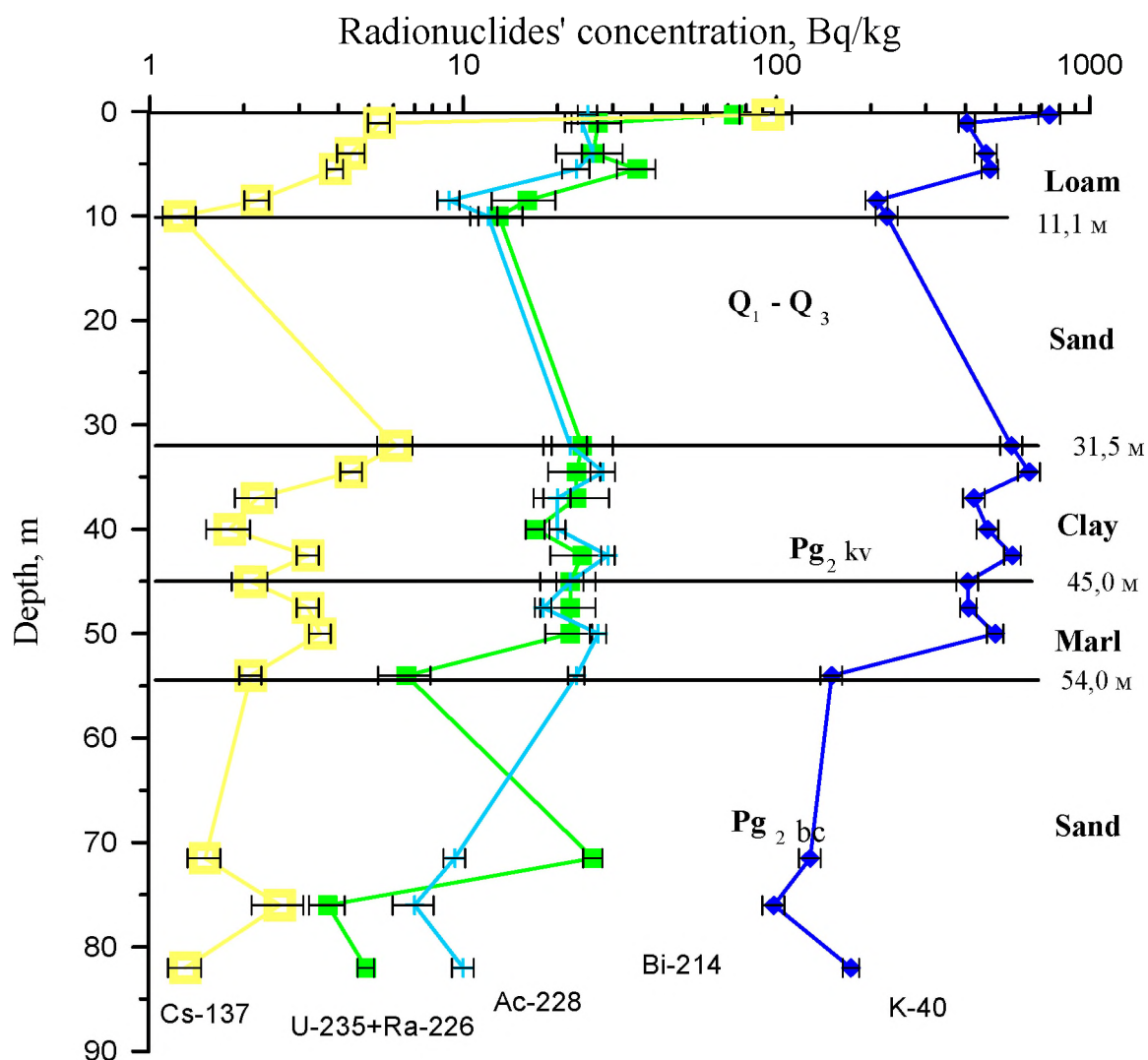

Fig. 1. Distribution of artificial and natural occurring radionuclides in the core of well No1. Village of Gorbovychi, Kyiv region.

TABLE 6. Radiocaesium and some natural occurring radionuclides in the core of the well No1, village of Gorbovichi, Kiev region (Bq/kg)

No	Rock's specifics (*)	Depth, m	^{137}Cs	^{40}K	^{228}Ac	^{214}Bi
1	Soil-plant layer (1)	0.3	148	743	73	25
2	Loam (5)	1.1-10.0	<0.41-1.31	209-480	13-36	9-26
3	Green clay (3)	32-37	0.24-0.92	382-640	23-28	17-28
4	Kiev marl (6)	40-54	0.27-3.4	150-566	6.6-25	18-29
5	Sand (3)	71.5-82.0	0.16-0.37	98-173	3.7-26	7-10

* - number of samples

Taking into account comparatively low area contamination inside the KIUA, we have tried to make similar measurements in the alienated zone around the CNPP. This area has no significant depression cone, but has a very high surface contamination by decay products. Several boreholes had been drilled on the so-called Vesniane site, located on the western trace of radioactive fallout. Sampling was at the same time with drilling. Soils and rocks had been

taken from the drilling tools before the worm was put on the contaminated surface to prevent sample's contamination. During the first sampling session the first samples had been taken from the depth of 0.5 m to avoid contact with huge contaminated upper parts of the section. For a half year upper part of it had been in detail examined by the pit. Results of these patterns' measurements are represented in the Fig.2 and 3.

We have to underline that well No 3 had been put in the centre of little depression, so called "steppe plate", which consider as an area with increased groundwater recharge (Shestopalov a.o. 1999). So a velocity of vertical radionuclides' and infiltration water's migration here must be higher than that on the background sites.

Although sampling conditions were quite severe, from the possibility of artificial patterns' contamination point of view, results obtained may be estimated as satisfactory. Practically geterogenic distribution of all radionuclides under study in the upper 20 cm of the soils has a simple explanation - this area was carefully tilled by wild boars.

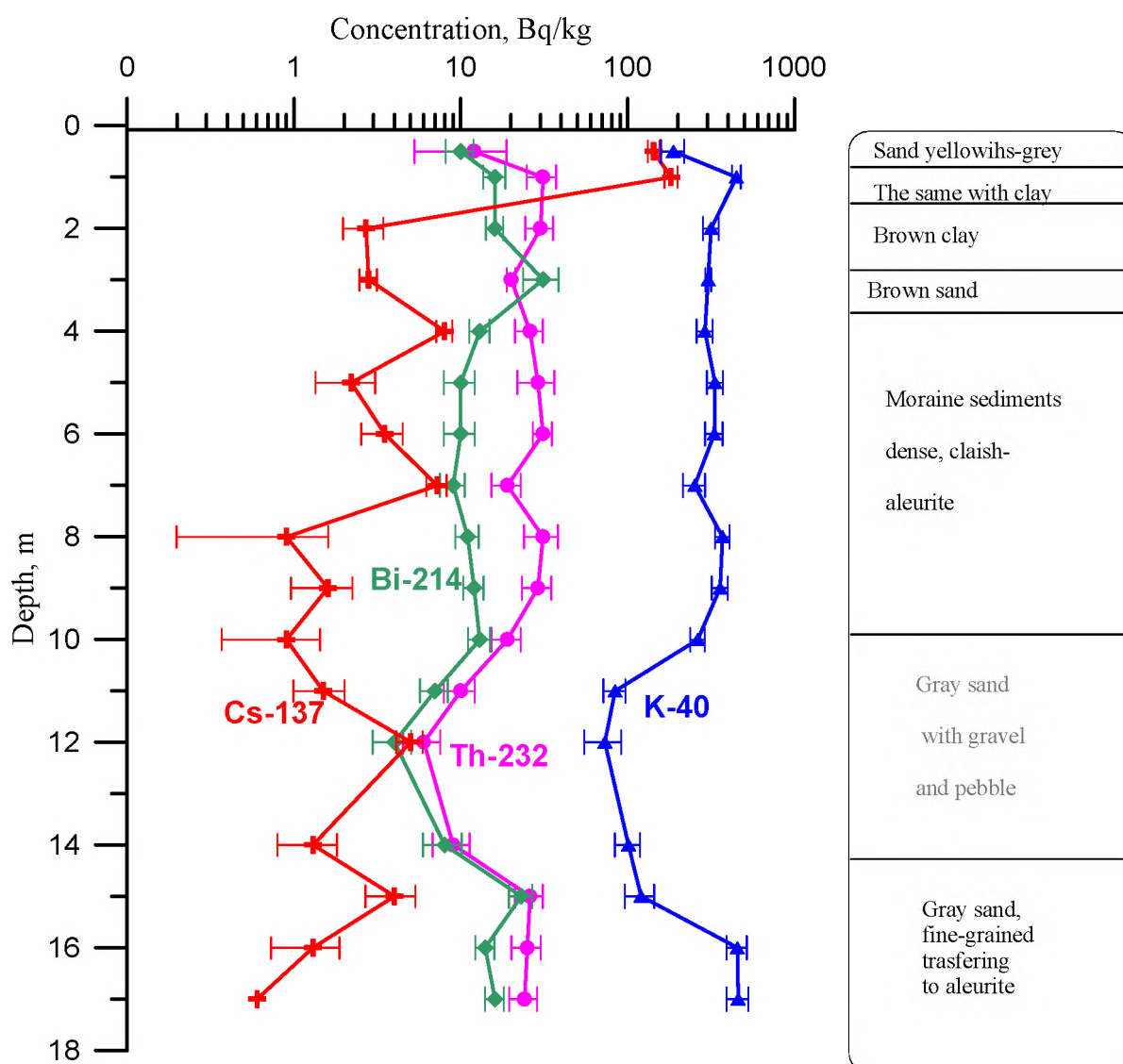

Fig.2. Concentration of radionuclides versus depth. Alienated zone around CNPP, Vesniane site, well No 3, drilled in the depression 28.11.98.

As can be seen from the fig.2, significant concentration of ^{137}Cs are observed practically along all 17 m of rocks. A range of peaks exists, reflecting, may be, geochemical barriers. Shape of ^{40}K and ^{232}Th (lower than 10 m - and ^{226}Ra - ^{214}Bi) curves are similar one another. Their breaks are corresponding to lithological boundaries. Behaviour of the ^{137}Cs , possibly transferred by the infiltration flow, significantly another.

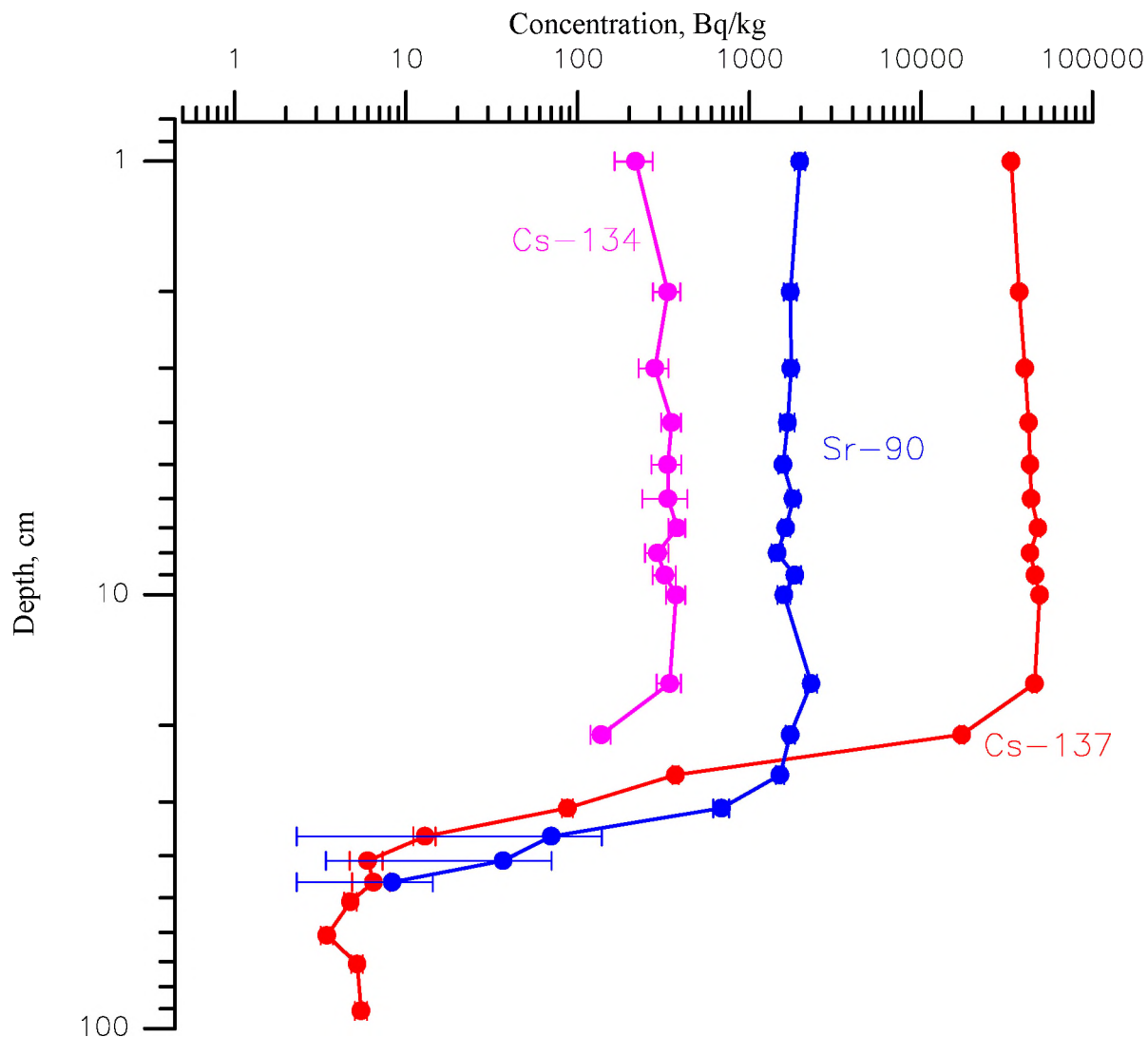

Fig. 3. Vertical distribution of radionuclides in the pit, located near well No 3. Alienated zone around CNPP. Vesniane site. 1999

Detail sampling of the upper part of cross-section, disturbed by boars (Fig. 3), shown the difference between chemical properties of caesium and strontium compositions - concentration of ^{90}Sr are decreasing slower than that of ^{137}Cs , which specified with high sorption ability especially to the clayish minerals.

So comparison of cores' measurements, collected in comparatively clean city-of-Kiev and very contaminated alienated zone around CNPP support the idea about the existence of downward movement dissolved compositions of ^{137}Cs and ^{90}Sr . This flow is very weak, but

sometimes, as we shall show below, may reach significant values to be taken into account during the forecast of a groundwater contamination.

Sampling in constructing metro tunnels. The next object for study possible radionuclides penetration through the unsaturated zone is so called kyiv marls, collected from the constructing metro tunnels. The third line of city metro is running now in the northwestern direction from the centre on the elevated right bank of the Dnieper-river. Tunnels are driving on the depth about 80 m in the Eocene deposits. Earlier kyiv marls serve as underlying aquitard for water bearing so called Kharkiv sandy-clayish deposits. But during the long-term exploitation of Cretaceous and Jurassic aquifers (depression cone reaches up to 80 m odd of depth) Kharkiv aquifer was found to be completely dried. So recently kyiv marls (inside the central part of agglomeration) locate in the unsaturated zone.

The sampling started in 1994, when some marl patterns, excavated from the constructing tunnel, had been measured by γ -spectrometer. Results obtained stimulated a continuation of works. Now measurements of marl's radioactivity are added by moisture determination and investigations of the porous solutions.

The trace of metro locates far enough from the exploitation wells, so vertical penetration of the Chernobyl origin radionuclides are weak influenced by the local depressions. If this assumption is correct, the appearance of measurable radionuclides' concentrations in kyiv marls indicates a zones of quick migration. During the sampling sessions main attention was paid to avoid artificial contamination.

Some new data about the distribution of ^{137}Cs , some naturally occurring radionuclides and moisture of the marls along the constructing tunnels are presented in the table7. Radionuclides' distribution along the new tunnel is presented in Fig.4.

Taking into account very low concentrations of ^{137}Cs in the samples of marl, and, accordingly, high uncertainties of their measurements, heavily to search any correlation between this parameter and gravimetric moisture of rocks. Going on investigations of the porous solutions, picked out of samples, may be allow to bind the plots with increased infiltration flow and more or less increased concentration of radiocaesium in the marl.

TABLE 7. Moisture and radioactivity of kyiv marls from the constructing metro tunnel. City-of-Kiev, 1998–2000

Statistical parameters	Geological and radiological parameters			
	Gravimetric moisture, %	Concentration of ^{137}Cs , Bq/kg	Concentration of ^{40}K , Bq/kg	Concentration of ^{214}Bi (^{226}Ra), Bq/kg
Number	43	29	29	29
Average mean	27.96	0.649	515.1	21.16
Standard deviation	2.327	0.417	66.47	3.50
Min	20.2	0.06	408	17
Max	37.2	1.75	734	33

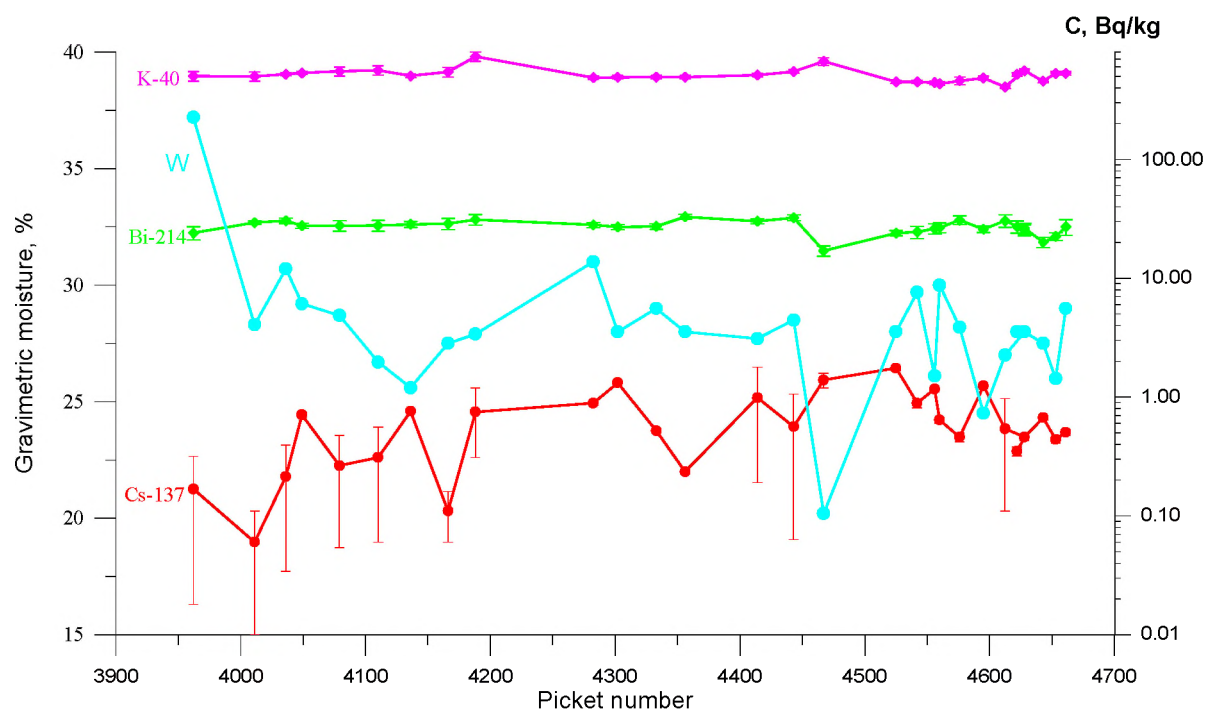

Fig.4. Distribution of moisture and radionuclides in the kyiv marls along the new constructing metro tunnel. Every picket has 100 m length

Soil profiles near the operating wells. The most impressive evidence of the powerful downward migration of Chernobyl origin radionuclides had been obtained during the study of ^{137}Cs redistribution in the soil profiles near the operating wells of the municipal water intake system. Comparatively quick artificial radionuclides' migration from the daylight surface had been observed during the monitoring of groundwater contamination inside the depression cone of Kiev water intake. Study of space-temporal distribution of ^{137}Cs in the soil profiles, located on the different distances from the wellheads allows to search very specific shape of the curves near the bores. Inside the circle of 5–10 m radius around the wellheads upper part of the vadose zone (up to dozen centimetre thickness) loosed more than half of radionuclide's storage for eight years. A range of chromatography like peaks had been observed in the soil to the depth of 1 m and might be more. Radiocaesium's vertical distribution supports the idea that weakened annulus zone around the water production wells plays in important role in the radionuclide's migration to the aquifers.

Phenomenon of surface contaminants' accelerated migration to aquifers in the close vicinity to the operating wells is known quite well. Strictly speaking the existence of this effect stipulates the necessity of the special measures to support a cleanness of daylight surface in the limits of sanitary zones around the water intakes. Observations over the artificial radionuclides' behaviour, released during the Chernobyl disaster, allow to assess the scale of groundwater contamination process as a consequence of increased migration inside the depression cones of the operating wells. Series of sampling had been carried out to assess the influence of the operating wells on the vertical migration of the surface pollution at the different distances from their mouths. Some examples are represented on the Figs 5–7.

Some other plots, concerning the redistribution of ^{137}Cs in the near pipe zones are represented in the Appendix. Comparison of radiocaesium storage in soils near some operating wells had shown that about 90 % of radionuclide had been carried out from the upper layer of the soil for the last 8 years near the 10-th well, about 100% (99.75) near the well 15(14) and only 64 % near the well 221. The last observation shows visible correlation between ^{137}Cs concentration and gravimetric moisture of the soil in the close vicinity of some operating wells (See Fig. 8).

Character of relationship between ^{137}Cs concentration and moisture of soil in the near pipe space allow to suppose that a portion of water after the rain take a bit of dissolved or suspended radionuclide from the daylight surface and transfers downward. Visible peaks of moisture and radiocaesium on the depth up to 1 m are observing only near the mouths of operating wells. Monitoring of the decay products in the groundwater of Cretaceous and Yurassic aquifers shows certain correlation with an atmospheric precipitation.

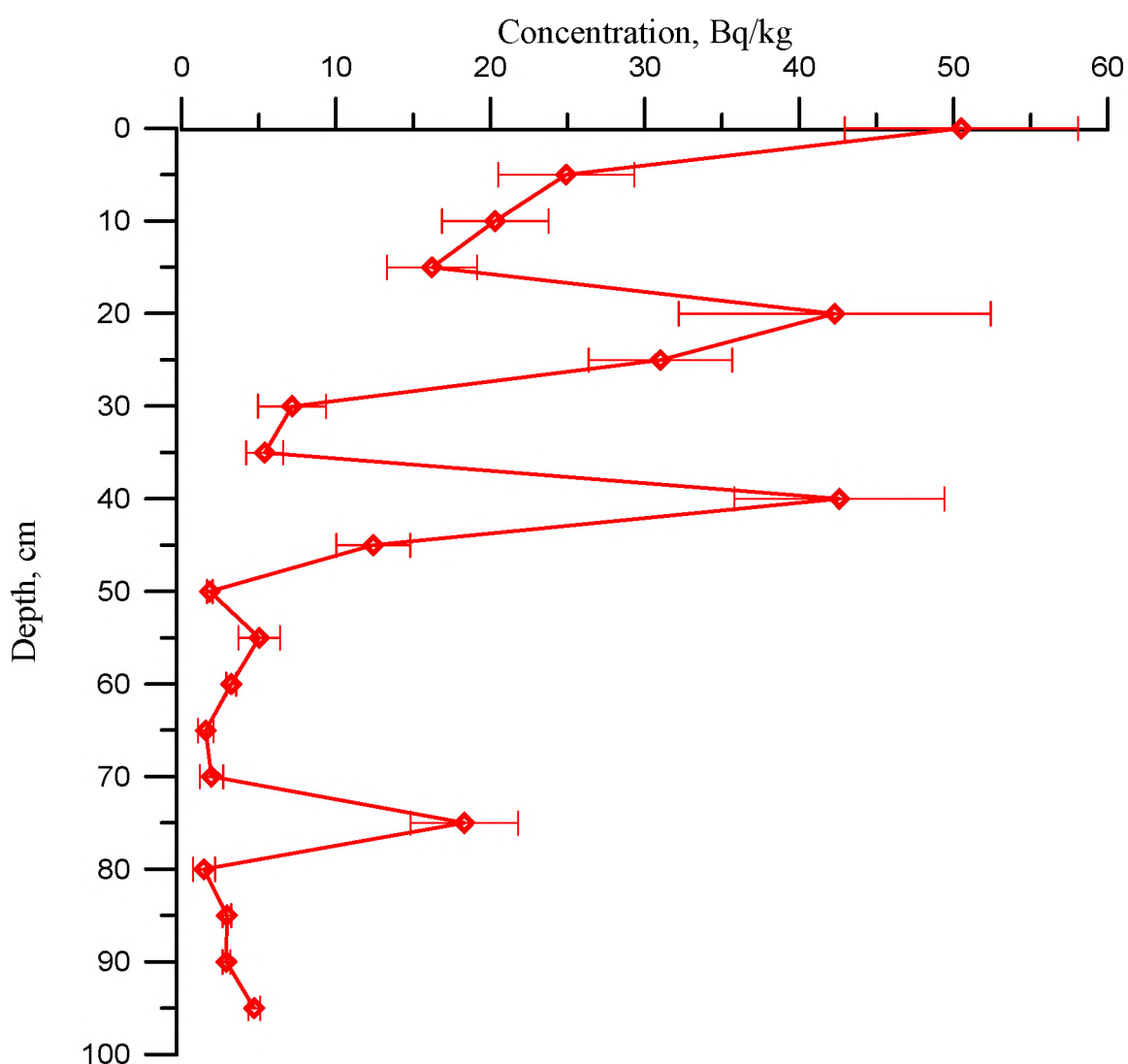

Fig. 5 Radiocaesium in the soil versus depth in the pit at 1.5 m from the mouse of the operating well #10. KIUA, November 1998.

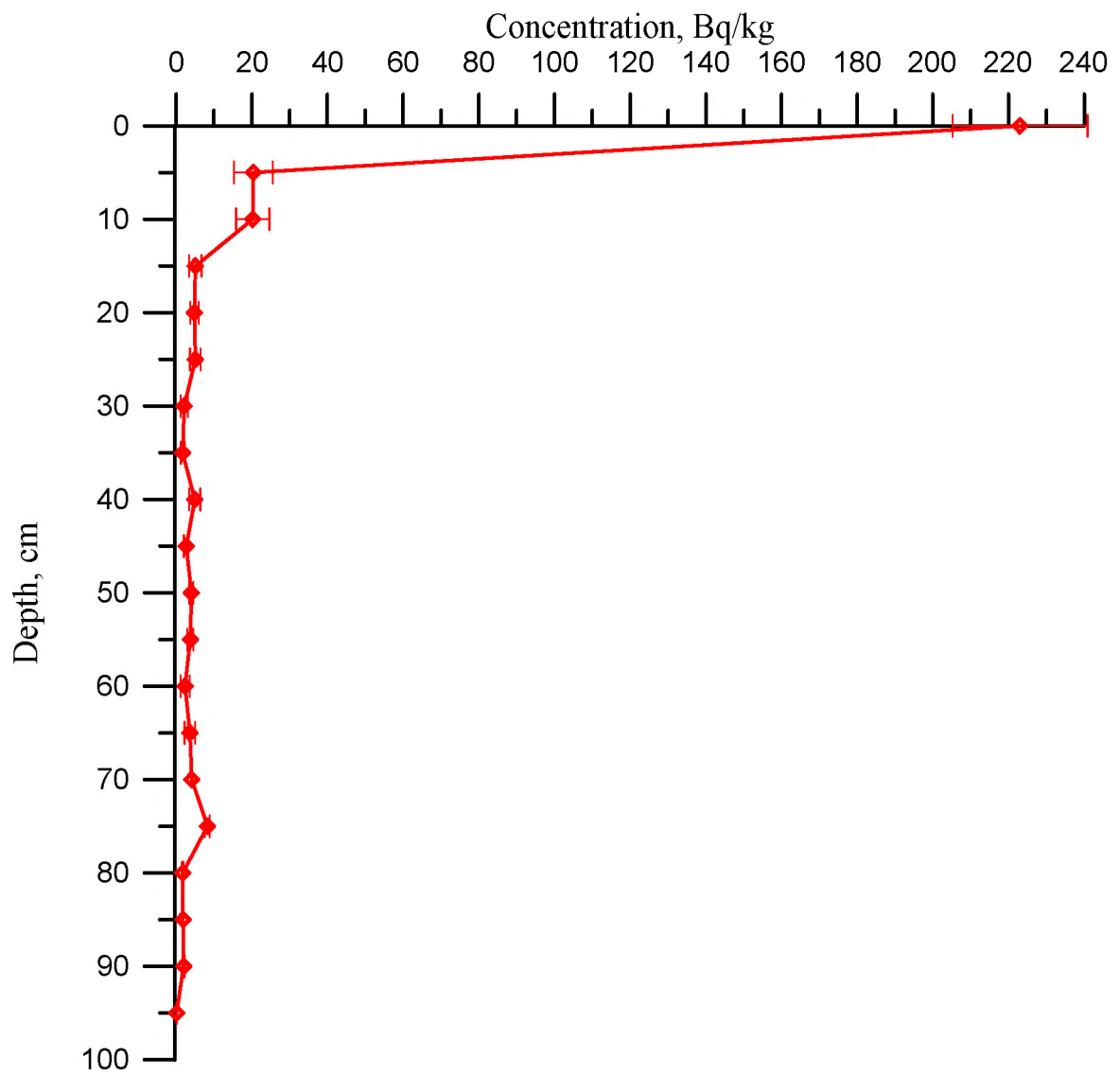

Fig. 6. Radiocaesium in the soil versus depth in the pit at 10 m from the mouse of the operating well # 10. KIUA, November 1998.

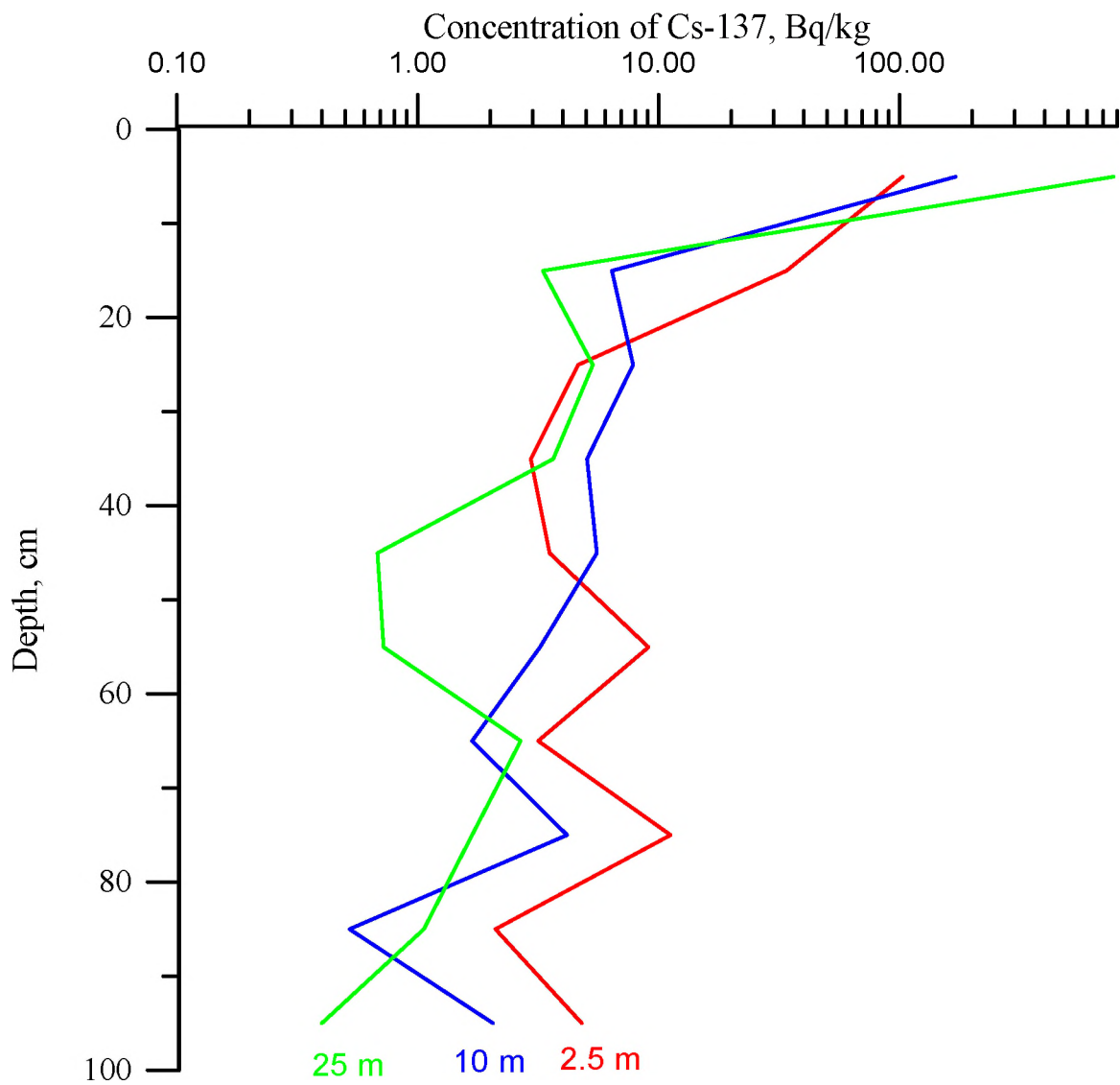

Fig.7. Concentration of Cs-137 versus depth of soil profile on the different distances from the pipe of operating water intake well 221. City-of-Kyiv, Dnieper's flood plain. 28.04.99 .

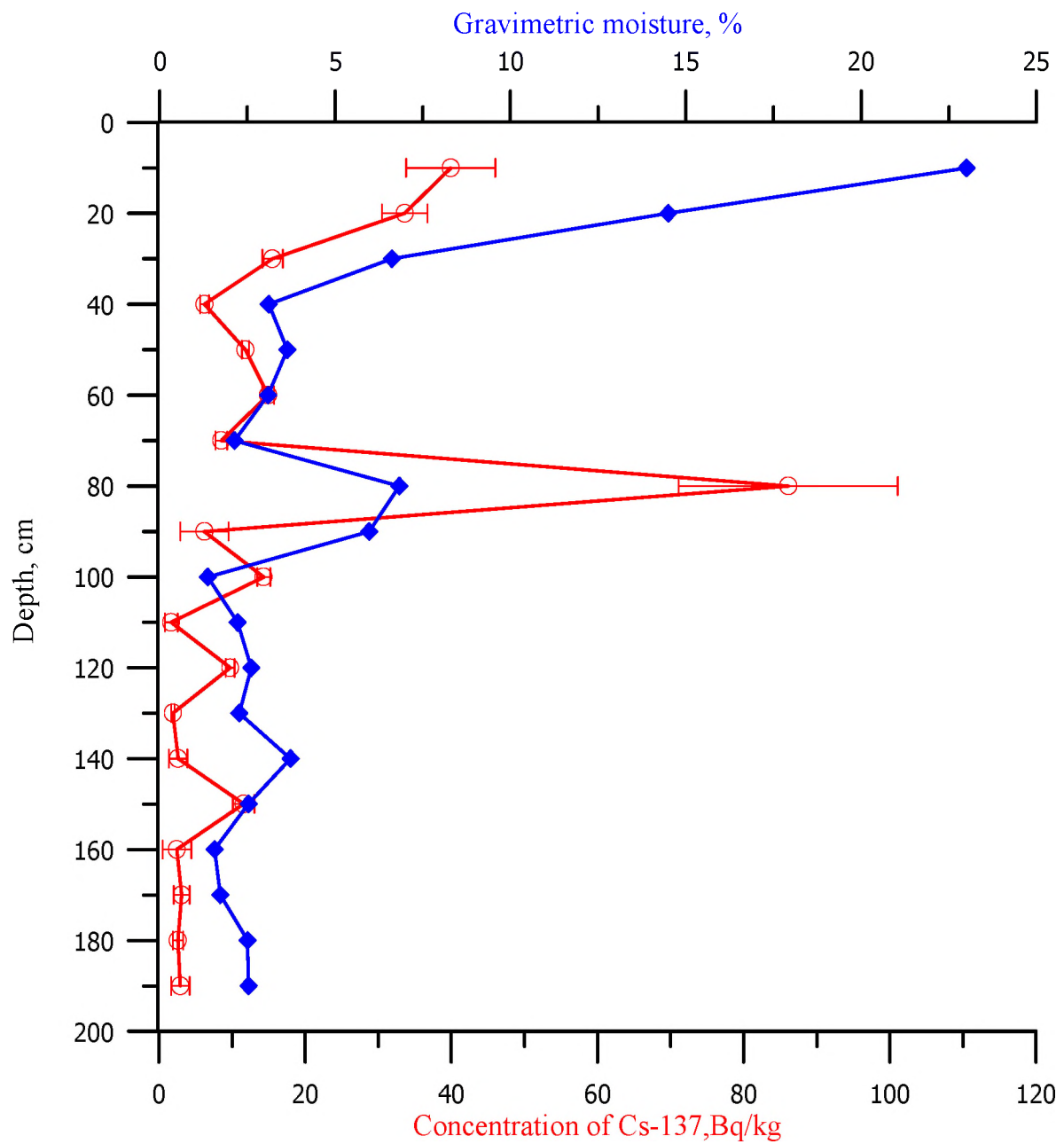

Fig 8. Gravimetric moisture versus concentration of Cs-137 in the soil profile at 10 m westward from the mouth of operating water intake well No 361 (City-of-Kyiv, 27.09.2000).

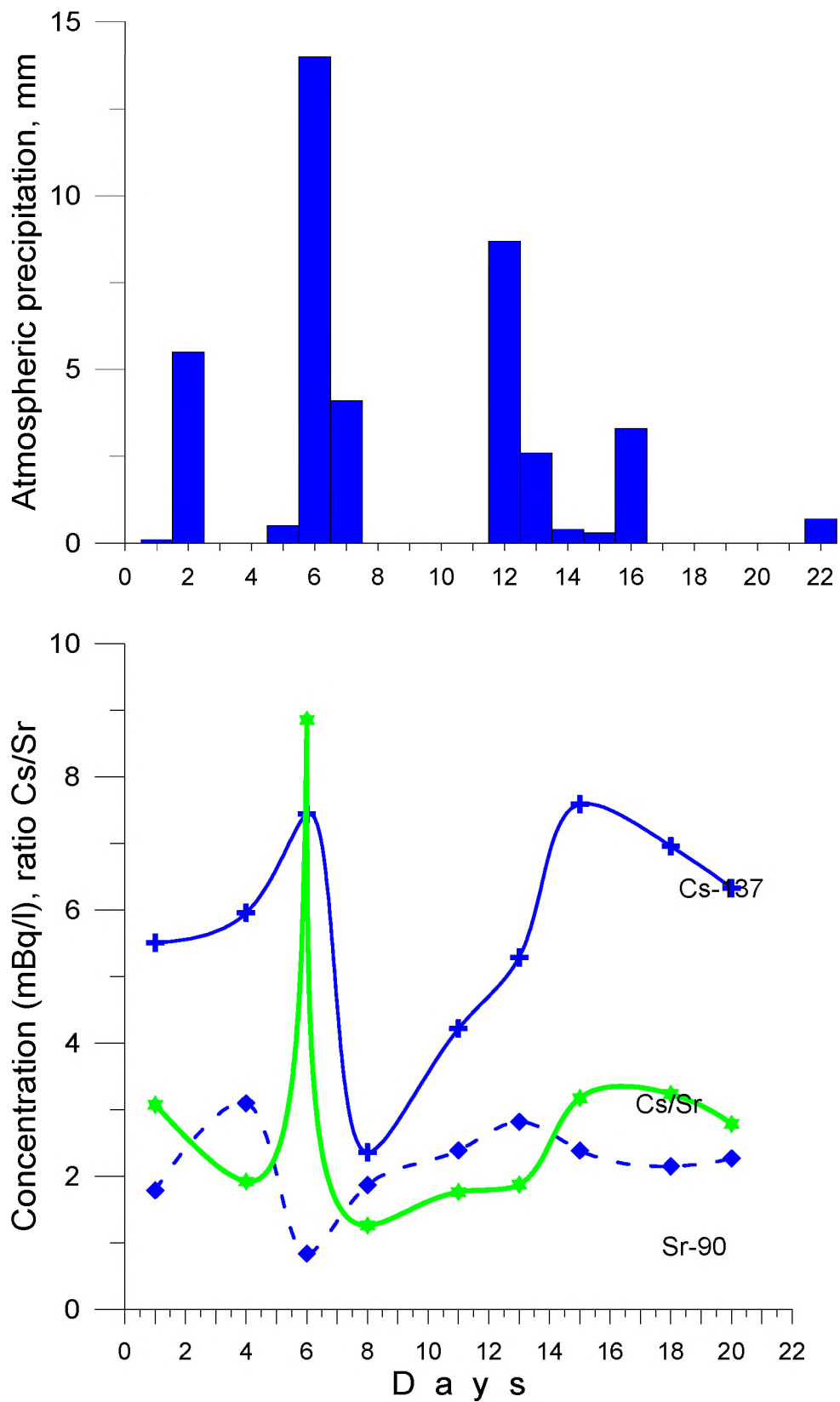

Figure 9. Short period monitoring of radionuclides concentration in the water of exploitation well #360 (K2cm) versus atmospheric precipitation.

CONCLUSIONS

An analysis of results obtained allows to make following conclusions:

- geological medium inside the KIUA is contaminated with the decay products of Chernobyl origin;
- groundwater of all aquifers up to depth of 250 odd meters contains measurable amounts of ^3H , ^{137}Cs and ^{90}Sr ;
- presence of these radionuclides in the groundwater, soils and sinters of drainage adits of landslide slopes support the idea about existence of contaminated infiltration flow, which intercepts by drainage systems;
- vertical distribution of radiocaesium in the soils in the limits of the first meters from wellheads confirms the existence of the powerful downstream flow, which is possible to transfer radionuclides from the daylight surface to the geological medium;
- main cause of the quick radionuclides' downward penetration is the existence of large regional depression cone, formed as a result of long term groundwater exploitation in the KIUA;
- annulus space around the exploitation wells seems to be main pathway for radionuclides from daylight surface to the groundwater at least in the limits of KIUA, although alternative pathways may be important too, especially in the faults zones, karst regions and specific landscapes of "steppe plate" type.

REFERENCES

- [1] A.B. KLIMCHOUK, V.V. GUDZENKO (1996) Chernobyl radiocaesium in a carst system, Marble Cave, Krimea // *Environmental Geology*, 28/3, 161–166.
- [2] V.M. SHESTOPALOV, V.N. BUBLIAS, A.S. BOHUSLAVSKY (1999) Anomalous zones of radionuclides migration in geological environment (experience of Chernobyl) TESEC-PR DOC-15/99, Kiev, 76 p.

PAPERS PUBLISHED ON WORK DONE UNDER THE CONTRACT

V. GOUDZENKO (1997) Artificial radionuclides as a tool for groundwater contamination assessment: Experience following the Chernobyl disaster. In *Groundwater in the Urban Environment. Vol.1, Problems, Processes and Environment*, Balkema, Rotterdam, 1997 p.141–144.

V. SHESTOPALOV, V. GOUDZENKO, YU. RUDENKO, V. BUBLYAS AND A. BOGUSLAVSKY (1997) Assesment and forecast of groundwater and rock contamination within the Kiev industrial agglomeration influenced by Chernobyl fallout. *Ibid*, 171–174.

V. BUBLYAS, V. GUDZENKO, I. ONYSHCHENKO, YU. RUDENKO, A. SHEVCHENKO and V. SHESTOPALOV (1999) Hydrogeology and Land Use Management. *Proc. of XXIX IAH Congress Bratislava, 1999*, 347–352.

V. GUDZENKO and D. KUKHARENKO (2000) Assessment of the urban areas' geological medium permeability by radionuclides. In *Proceeding of the Conference "Ecological geology and rationally land use" San-Petersburg, Russia, 349–351 (in Russian)*.

LIST OF PARTICIPANTS

Bossew, P.
University of Salzburg, Department of Biophysics, Salzburg, Austria

Da Costa Lauria, D.
Instituto de Radioprotecao e Dosimetria, Av. Salvador Allende, s/n, Jacarepagua,
Cx. Postal 37750-CEP 22642-970, Rio de Janeiro, Brazil

Gudzenko, V.
R&D Centre for Radio, Environment Studies,
Presidium of National Academy of Sciences,
Kiev, Ukraine

Kadatsky, V.
Institute for Problems of Natural Resources Use & Ecology,
National Academy of Sciences of Belarus,
Minsk 220114, Belarus

Klyashtorin, A.
Faculty of Soil Science, Moscow State University,
119899 Moscow, Russian Federation

Komosa, A.
Marie Curie-Sklodowska University,
Department of Radiochemistry & Collokd Chemistry,
20-031 Lublin, Poland

Monte, L.
ENEA CR Casaccia, AMB-PRO-IRP, Via Anguillarese 301,
S. Maria Di Galeria, Casella Postale n.. 2400-00100,
I-01060 Rome, Italy

Tarasyuk, N.
Institute of Physics, Gostauto 12, 2600 Vilnius, Lithuania

