

PATENTS-US--A7126153

126,153(8))
pd 11-30-87

PATENTS-US--A7126153

S-61,470

DE89 010954

RL-9367

IL-7437

W-7405-ENG-48

Daniel Pinkel

FLOW CYTOMETRY APPARATUS

By: Daniel Pinkel USA
31 Manzanita Court
Walnut Creek, CA 94595

FLOW CYTOMETRY APPARATUS

126,153

DISCLAIMER

This report was prepared as an account of work sponsored by an agency of the United States Government. Neither the United States Government nor any agency thereof, nor any of their employees, makes any warranty, express or implied, or assumes any legal liability or responsibility for the accuracy, completeness, or usefulness of any information, apparatus, product, or process disclosed, or represents that its use would not infringe privately owned rights. Reference herein to any specific commercial product, process, or service by trade name, trademark, manufacturer, or otherwise does not necessarily constitute or imply its endorsement, recommendation, or favoring by the United States Government or any agency thereof. The views and opinions of authors expressed herein do not necessarily state or reflect those of the United States Government or any agency thereof.

DISTRIBUTION OF THIS DOCUMENT IS UNLIMITED

DISCLAIMER

This report was prepared as an account of work sponsored by an agency of the United States Government. Neither the United States Government nor any agency thereof, nor any of their employees, makes any warranty, express or implied, or assumes any legal liability or responsibility for the accuracy, completeness, or usefulness of any information, apparatus, product, or process disclosed, or represents that its use would not infringe privately owned rights. Reference herein to any specific commercial product, process, or service by trade name, trademark, manufacturer, or otherwise does not necessarily constitute or imply its endorsement, recommendation, or favoring by the United States Government or any agency thereof. The views and opinions of authors expressed herein do not necessarily state or reflect those of the United States Government or any agency thereof.

DISCLAIMER

Portions of this document may be illegible in electronic image products. Images are produced from the best available original document.

FLOW CYTOMETRY APPARATUS

BACKGROUND OF THE INVENTION

The United States Government has rights in this invention pursuant to Contract No. W-7405-ENG-48 between the U.S. Department of Energy and the University of California, for the operation of Lawrence Livermore
5 National Laboratory.

Flow cytometers/sorters have been developed over the last few decades to automate the counting or separation of body tissue cells and organelles in aqueous suspension. An important part of every flow
10 cytometer/sorter is its flow chamber. It must be designed to have satisfactory hydrodynamic, optical, mechanical, and electrical characteristics. To obtain accurate measurements it is important that all the particles pass through the region of uniform sensitivity of the sensors.
15 This is accomplished using a method called hydrodynamic focusing. In hydrodynamic focusing a flow of "sheath"

fluid is established through a constricting nozzle. The suspension of sample particles is introduced into the sheath fluid from a small tube (sample tube) and is carried along a streamline of the sheath flow in the flow direction.

In the measuring or sorting of certain flat cells such as sperm cells, it is important that the cells are properly oriented. In the past, properly orienting certain flat cells has been inefficient and slow. In the prior art, flow chambers with a slotted nozzle orifice, or wedge shaped sample tubes are used to orient flat cells. The prior art is discussed more fully in "Flow Cytometry: Instrumentation and Data Analysis," edited by Marvin A. Van Dilla, Phillip N. Dean, Ole D. Laerum, and Myron R. Melamed, Academic Press Inc. 1985, incorporated herein by reference.

This invention relates to a method and apparatus for orienting certain flat cells. The advantage of this invention is its ability to achieve adequate cell orientation at much higher sample measurement rates.

SUMMARY OF THE INVENTION

An object of the invention is to more efficiently measure or sort flat cells.

Another object is to more quickly measure or sort flat cells.

Another object is to more accurately measure or sort flat cells.

5 Another object is to properly orient flat cells in a cell flow cytometer/sorter.

Another object is to properly orient flat cells supplied at a faster flow rate.

10 Additional objects, advantages and novel features of the invention will be set forth in part in the description which follows, and in part will become apparent to those skilled in the art upon examination of the following or may be learned by practice of the invention. The objects and advantages of the invention
15 may be realized and attained by means of the instrumentalities and combinations particularly pointed out in the appended claims.

The invention is a method or apparatus for orienting flat cells which comprises: a tubular flow
20 chamber through which a sheath fluid flows in a flow direction; an obstruction which causes the sheath fluid flow to converge in one dimension; and means for directing the flat cells in a sample fluid near to the area of the one dimensional convergence in the sheath fluid, which
25 orients the flat cells.

BRIEF DESCRIPTION OF THE DRAWINGS

The accompanying drawings, which are incorporated and form a part of the specification, illustrate embodiments of the invention and, together with the description, serve to explain the principles of the invention.

Figure 1 is a schematic drawing of a flow sorter with one embodiment of the invention.

Figure 2 is a cross sectional and enlarged view of the flow chamber along section 2--2.

Figure 3 is another cross sectional view of the flow chamber along section 3--3.

Figure 4 is another cross sectional view of the flow chamber along section 4--4.

Figure 5 is a cross sectional view of flow chamber of another embodiment of the invention.

Figure 6 is another cross sectional view of the flow chamber as shown in Figure 5 along section 6--6.

DESCRIPTIONS OF THE PREFERRED EMBODIMENTS

There are many different cell flow cytometer/sorters. Figure 1 shows a schematic view of one type of cell flow sorter with the invention. Flat cells, which may be stained with one or more fluorescent dyes, enter the flow chamber 6 through sample tube 8. A sheath fluid

is also introduced into the flow chamber through an entrance 10. The flat cells are carried in single file in the sheath fluid stream 12 through a focussed laser beam from laser 13 whose wavelength is adjusted to excite a fluorescent dye that may be present. Some of the fluorescence and/or light scatter produced during the laser beam crossing is focused by an objective lens 14 onto a beam splitter 16 and projected through spectral filters 18 and 20 onto photomultipliers 22 and 24. The photomultipliers 22 and 24 convert the fluorescence and/or light scatter to electrical pulses whose amplitudes are proportional to the total light reaching the photomultipliers. Similarly, a photomultiplier or a photodiode 25 detects fluorescence or scatter in the direction along the laser beam. The electrical pulses are sent to an electrical signal processor 26. Flat cells to be sorted are recognized by their distinctive fluorescence and/or light scatter intensities. After measurement, each flat cell flows in the sheath fluid stream 12 until it reaches the point where the stream 12 breaks into discrete droplets 30. A piezoelectric transducer 28 vibrates the flow chamber 6 causing the stream 12 to break into the discrete droplets 30. At the point where the stream 12 breaks into droplets 30, a charging collar 32 controlled by the electrical signal processor, induces an electrical

charge on each droplet containing a flat cell to be sorted. The droplets fall through a high electrostatic field where the charged droplets are deflected and collected by collector apparatus 33. The electrostatic
5 field is produced by deflection plates 34 and 36.

Figure 2 is a cross sectional view of the tubular flow chamber along section 2--2 in Figure 1, showing an embodiment of the invention. Figure 3 is a cross sectional view of Figure 2 along section 3--3. Figures 2
10 and 3 show a fin 40, which is a flat solid extending across the diameter of the flow chamber. Sample tube 8 extends through the flow chamber to the fin where it is in fluid connection with a passageway 47 which passes near to the center of fin 40 as shown. The fin is beveled to an
15 edge 44 as shown in Figure 4. The fin may have other possible shapes as long as they do not introduce turbulence into the fluid flow. The flat cells in a sample fluid flow through sample tube 8 to passageway 47 which terminates at aperture 48 where the sample fluid
20 enters the sheath fluid area. The shape of the aperture 48 is created by the cross section of the passageway 47 and the bevel of the fin.

The sheath fluid flows through the flow chamber in a flow direction from opening 43 to exit 45, and part
25 of fin 40 is upstream of the position where the flat cells

enter the sheath fluid area. Part of fin 40 may extend downstream from the aperture 48. The beveled fin 40, which lies along a plane that is parallel to the central axis of the flow chamber, causes the sheath fluid to converge in one dimension at its downstream edge, which causes the flat cells to orient themselves in the plane of convergence.

Figures 5 and 6 are illustrations of another embodiment of the invention. In this embodiment a cylindrical rod 50 is used to create the streamline convergence in one dimension. The obstruction of rod 50 is perpendicular to the axis of the flow chamber 54, and the rod extends across the diameter of the flow chamber 54. In this embodiment the passageway 52 inside rod 50 directs the sample fluid to aperture 56, where the sample fluid is released into the sheath fluid. The sheath fluid flows through the flow chamber from opening 53 to exit 55. The obstruction 50 creates a convergence in one dimension along the length of the obstruction. The obstruction 50 is upstream from where the flat cells enter the sheath fluid at aperture 56 and positioned to cause the flat cells to pass through part of the convergence in one dimension, thus orienting the flat cells. Fins 58 are located near this aperture to limit the lateral diffusion of the sample fluid on the downstream side of the

obstruction 50 before the sample fluid enters the sheath flow.

The foregoing description of preferred
embodiments of the invention have been presented for
5 purposes of illustration and description. It is not
intended to be exhaustive or to limit the invention to the
precise form disclosed, and obviously many modifications
and variations are possible in light of the above
teaching. The embodiments were chosen and described in
10 order to best explain the principles of the invention and
its practical application to thereby enable others skilled
in the art to best utilize the invention in various
embodiments and with various modifications as are suited
to the particular use contemplated. It is intended that
15 the scope of the invention be defined by the claims
appended hereto.

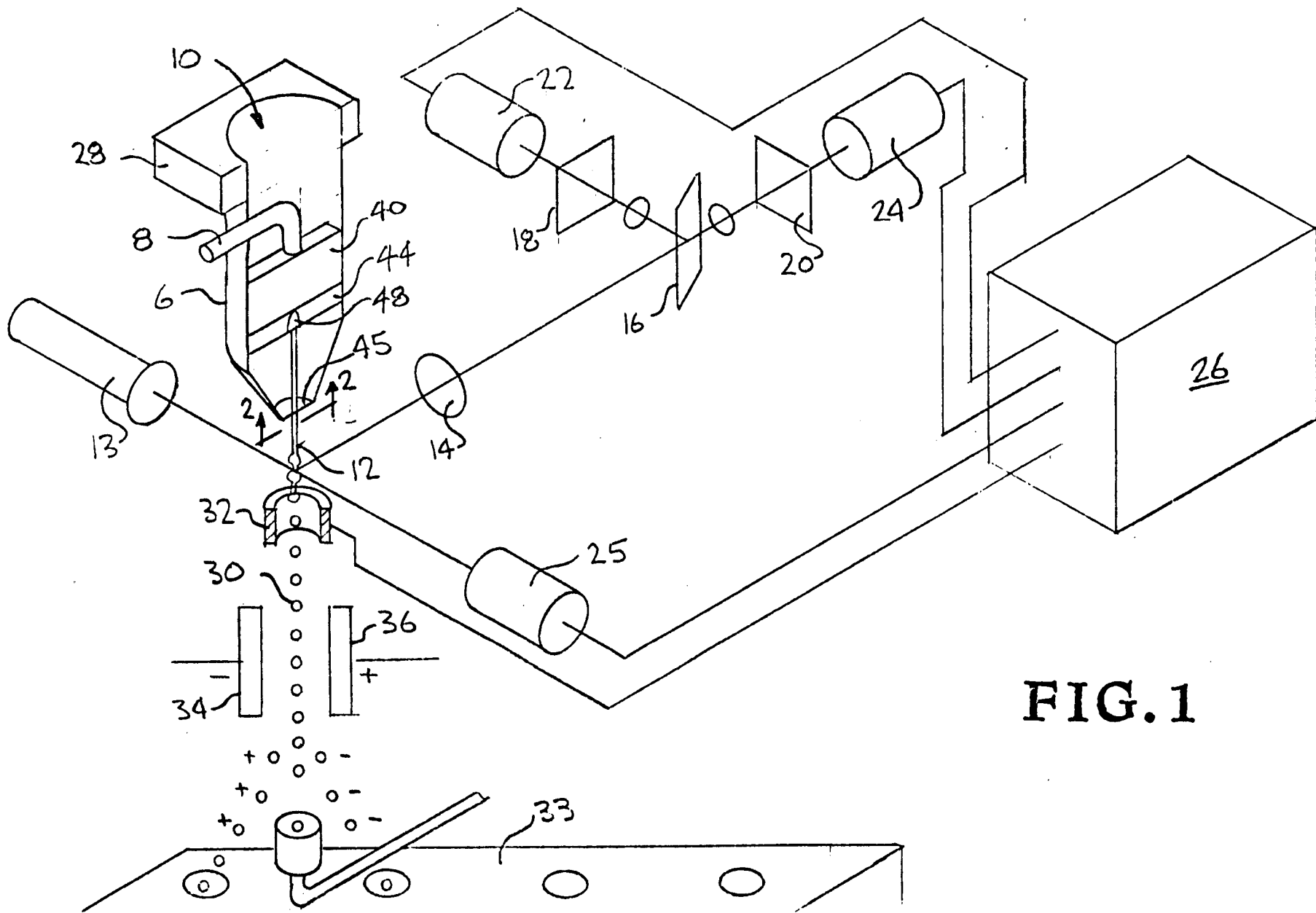

FIG. 1

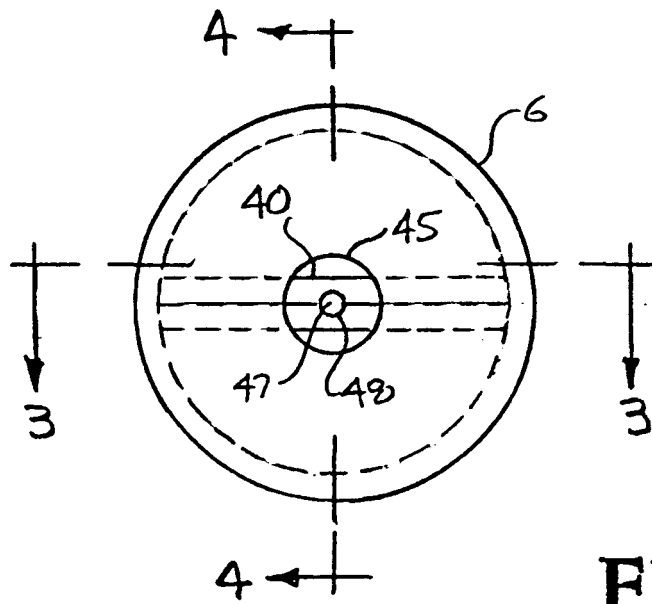

FIG. 2

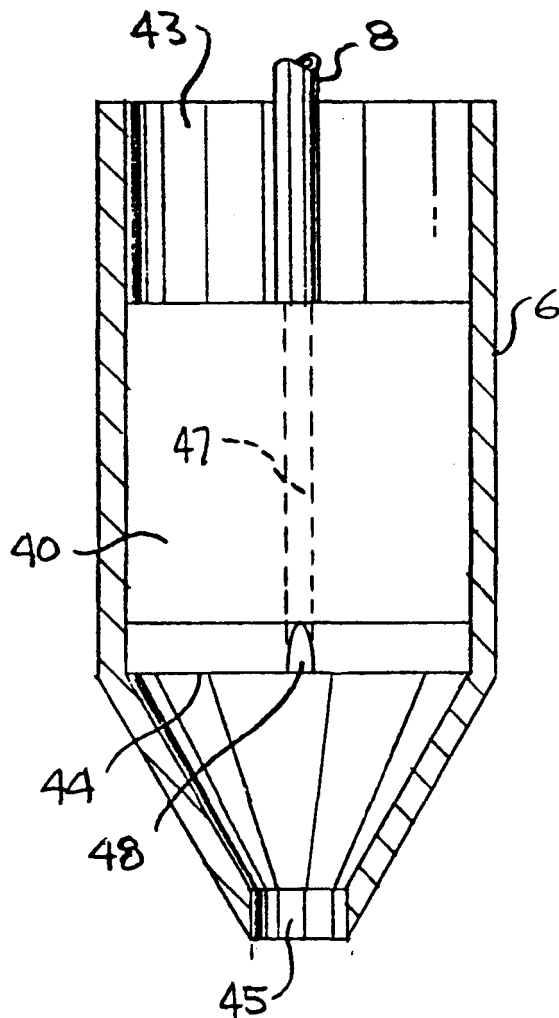

FIG. 3

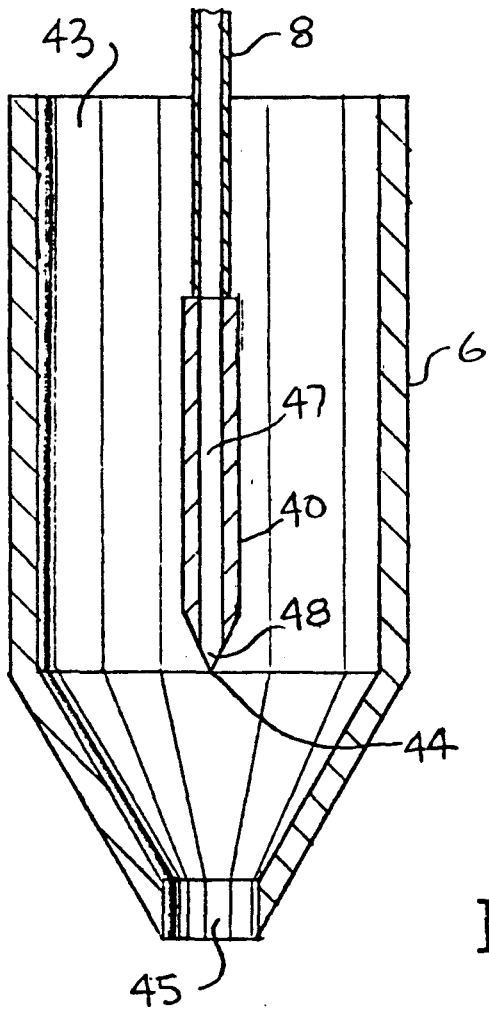

FIG. 4

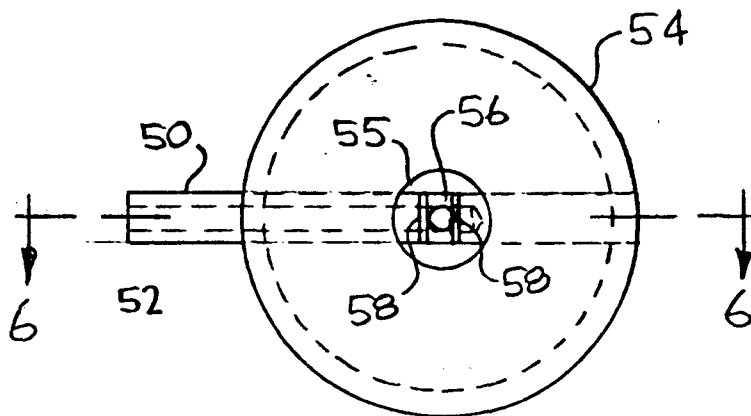

FIG. 5

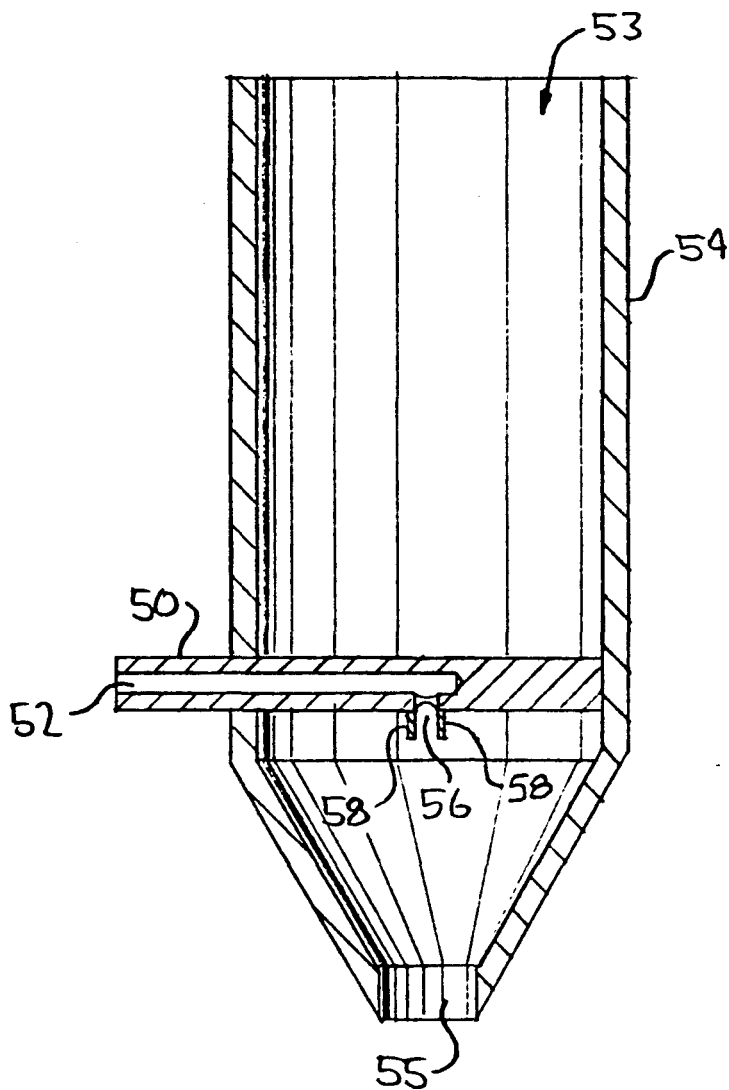

FIG. 6

FLOW CYTOMETRY APPARATUS

ABSTRACT OF THE DISCLOSURE

An obstruction across the flow chamber creates a one dimensional convergence of a sheath fluid. A passageway in the obstruction directs flat cells near to the area of one dimensional convergence in the sheath fluid to provide proper orientation of flat cells at fast rates.

5